

OCR

Oxford Cambridge and RSA

Thursday 14 January 2016 – Afternoon

FSMQ INTERMEDIATE LEVEL

6989/01 Foundations of Advanced Mathematics (MEI)

Candidates answer on the Answer Sheet.

OCR supplied materials:

- Answer Sheet (MS4)

Other materials required:

- Eraser
- Scientific calculator
- Soft pencil
- Ruler

Duration: 2 hours



INSTRUCTIONS TO CANDIDATES

- Write your name clearly in capital letters, your centre number and candidate number on the Answer Sheet in the spaces provided unless this has already been done for you.
- Read each question carefully. Make sure you know what you have to do before starting your answer.
- Do **not** write in the bar codes.
- There are **forty** questions in this paper. Attempt as many questions as possible. For each question there are four possible answers, **A**, **B**, **C** and **D**. Choose the **one** you consider correct and record your choice in **soft pencil** on the separate Answer Sheet.
- **Read very carefully the instructions on the Answer Sheet.**

INFORMATION FOR CANDIDATES

- Each correct answer will score one mark. A mark will not be deducted for a wrong answer.
- This document consists of **28** pages. Any blank pages are indicated.

Formulae Sheet: 6989 Foundations of Advanced Mathematics

Area of trapezium = $\frac{1}{2}(a + b)h$

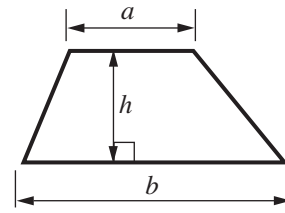

Volume of prism = (area of cross-section) \times length

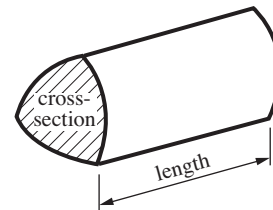

In any triangle ABC

Sine rule $\frac{a}{\sin A} = \frac{b}{\sin B} = \frac{c}{\sin C}$

Cosine rule $a^2 = b^2 + c^2 - 2bc \cos A$

Area of triangle = $\frac{1}{2}ab \sin C$

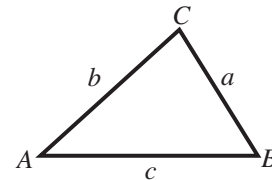

Volume of sphere = $\frac{4}{3}\pi r^3$

Surface area of sphere = $4\pi r^2$

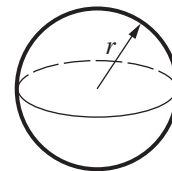

Volume of cone = $\frac{1}{3}\pi r^2 h$

Curved surface area of cone = $\pi r l$

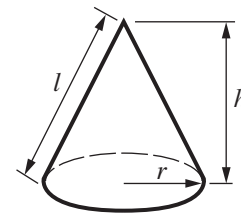

The Quadratic Equation

The solutions of $ax^2 + bx + c = 0$, where $a \neq 0$, are given by

$$x = \frac{-b \pm \sqrt{(b^2 - 4ac)}}{2a}$$

1 Three of the following statements are true and **one** is false. Which one is **false**?

A Written as a product of prime factors 84 is $2^2 \times 3 \times 7$.

B 36 has exactly 9 factors.

C The first five multiples of 2 are 2, 4, 8, 16 and 32.

D The lowest common multiple of 12 and 9 is 36.

2 Three of the following statements are true and **one** is false. Which one is **false**?

A $7\frac{1}{4} - 3\frac{1}{3} = 4\frac{1}{12}$

B $\frac{5}{7}$ of 3.5 = 2.5

C $16 \div 2\frac{1}{8} = 7\frac{9}{17}$

D $1\frac{3}{7} \times 2\frac{1}{3} = 3\frac{1}{3}$

- 3 Amit employs 8 people in his business. Their salaries are as follows.

£16 000 £16 000 £16 000 £16 000 £19 000 £25 000 £25 000 £46 000

Three of the following statements are true and **one** is false. Which one is **false**?

- A The mean salary is £22 375.
- B The median salary is £17 500.
- C The range of earnings of Amit's employees is £30 000.
- D The median salary increases if the salary of £46 000 is increased and the others remain the same.

- 4 You are given the formula $a = \frac{b^2 + c}{d}$.

Three of the following statements are true and **one** is false. Which one is **false**?

- A When $b = 5$, $c = -1$ and $d = 3$ then $a = 8$.
- B When $b = -4$, $c = 2$ and $d = 7$ then $a = -2$.
- C When $a = 10$, $b = 2$ and $c = 6$ then $d = 1$.
- D When $a = 6$, $b = 3$ and $d = 3$ then $c = 9$.

5 Three of the following statements are true and **one** is false. Which one is **false**?

A $400 \times 600 = 2.4 \times 10^5$

B $12 \div (1.5 \times 10^{-3}) = 8 \times 10^3$

C $4.3 \times 10^4 + 3.7 \times 10^3 = 4.67 \times 10^7$

D $\frac{8 \times 10^{-3} - 2 \times 10^{-4}}{3.9 \times 10^{-5}} = 2 \times 10^2$

6 Three of the following statements are true and **one** is false. Which one is **false**?

A The reciprocal of 4 is 0.25.

B The cube root of 27 is 3.

C The square of $\frac{1}{2}$ is 1.

D $\sqrt{2}$ is a real number.

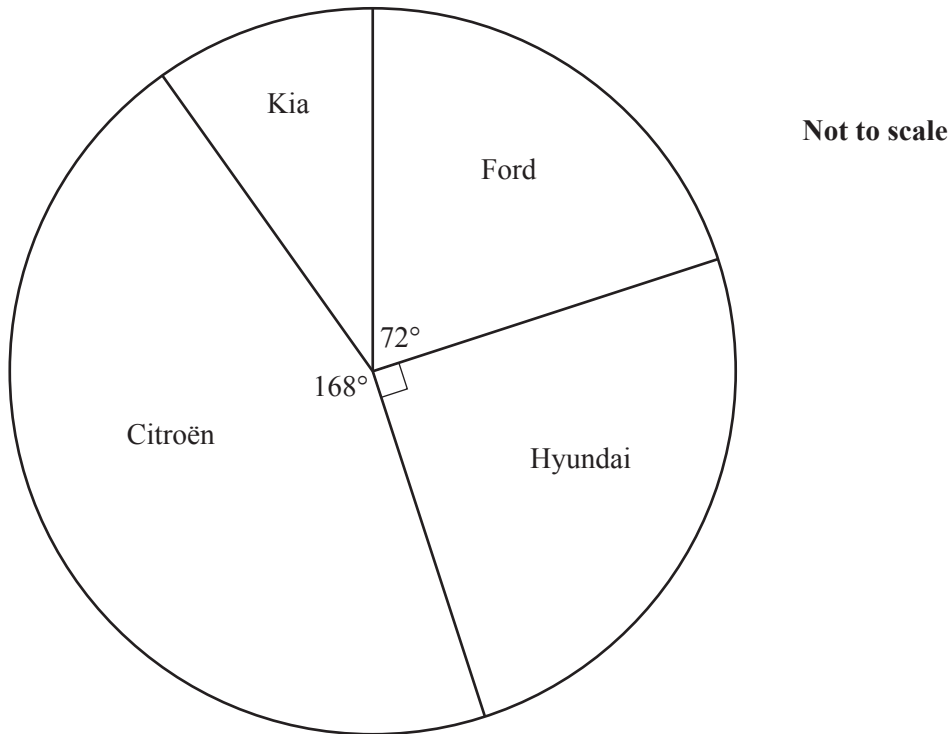

A taxi company employs 60 drivers. The pie chart shows the makes of their cars.

Three of the following statements are true and **one** is false. Which one is **false**?

- A 20% of the group have a Ford.
- B 6 drivers have a Kia.
- C A quarter of the drivers have a Hyundai.
- D A driver is chosen at random. The probability that this driver has a Citroën is $\frac{7}{15}$.

- 8 Three of the following statements are true and **one** is false. Which one is **false**?
- A The sequence $-2, 1, 4, 7, \dots$ has n th term $3n - 2$.
 - B 23 is a term in the sequence with n th term $n^2 + 2n - 1$.
 - C 486 is the 5th term in the sequence with n th term 2×3^n .
 - D The 8th term in the sequence with n th term $3n - 2$ is equal to the 8th term in the sequence with n th term $2n + 6$.
- 9 Three of the following statements are true and **one** is false. Which one is **false**?
- A 3.05 litres is equal to 3050 millilitres.
 - B 3 ft 6 in is approximately equal to 107 cm.
 - C 8 m^3 is equal to 8000 mm^3 .
 - D 25 kg is approximately equal to 55 lb.

10 Three of the following statements are true and **one** is false. Which one is **false**?

A $-20 + (4 - 5) - 4 = -25$

B $2 + 3 \times (-5) = -25$

C $-9 - (-2) = -7$

D $3 \times 2 - (4 - 5) = 7$

11 Three of the following statements are true and **one** is false. Which one is **false**?

A $x^2 - 7x + 12 = (x - 4)(x - 3)$

B One of the roots of the equation $x^2 = 6x$ is $x = 0$.

C The coefficient of x in the expression $3x^2 - 4x + 2$ is 4.

D The expression $2x^3 + 6x^2 - 3x$ has no constant term.

- 12 Three vectors are given by $\mathbf{p} = 3\mathbf{i} + 2\mathbf{j}$, $\mathbf{q} = -4\mathbf{i} - \mathbf{j}$ and $\mathbf{r} = \mathbf{i} + \mathbf{j}$.

Which **one** of the following is the **correct** value of $3\mathbf{p} - 2\mathbf{q} + \mathbf{r}$?

- A $2\mathbf{i} + 5\mathbf{j}$
- B $18\mathbf{i} - 9\mathbf{j}$
- C $18\mathbf{i} + 9\mathbf{j}$
- D $2\mathbf{i} - 5\mathbf{j}$

- 13 The headteacher of a school of 1200 students has asked the Student Council to investigate whether recent changes to the timings of the school day are popular with students. He wants the opinions to cover the different year groups.

Which **one** of the following is the **best** method of selecting a representative 10% sample?

- A Select 120 students at random from the school register.
- B Give questionnaires to all students and use the first 10% that are returned from each year group.
- C Select 10% of each year group at random.
- D Ask the first 120 students who arrive at school on one morning.

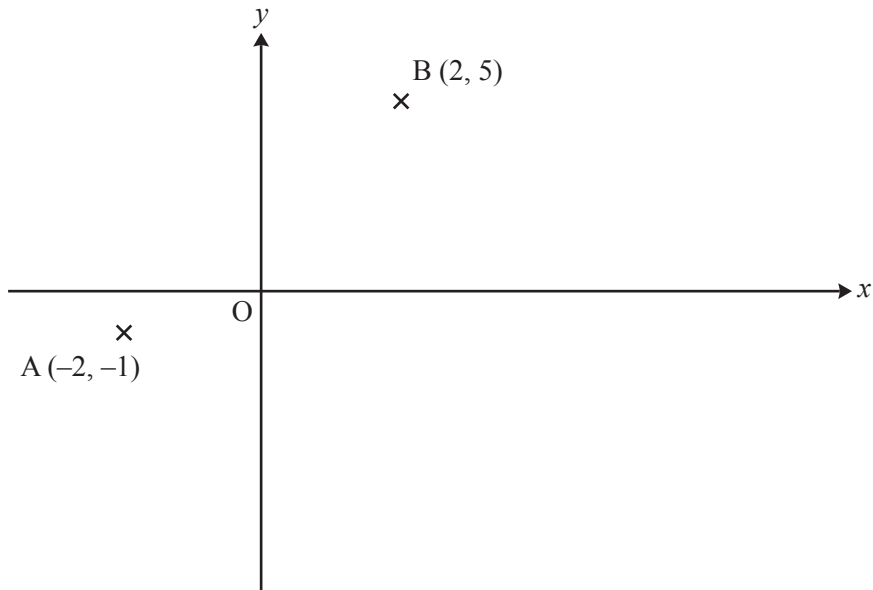

On the diagram, the coordinates of A are $(-2, -1)$ and the coordinates of B are $(2, 5)$.

Three of the following statements are true and **one** is false. Which one is **false**?

- A The coordinates of the midpoint of AB are $(0, 2)$.
- B The point $(4, 8)$ lies on the line which passes through A and B.
- C The length of line AB is $2\sqrt{13}$ units.
- D The equation of the line AB is $y = \frac{2}{3}x + 3$.

- 15 You are given the calculation $\frac{\sqrt{2.01 \times 3.66}}{5.32}$. The numbers are given correct to 3 significant figures.

Which **one** of the following answers is the most **appropriate** degree of accuracy to the calculation given above?

A 0.50983182

B 0.51

C 0.50983

D 0.509

- 16 Three of the following use **sensible** units of measurement and **one** does not. Which one does **not**?

A The length of a bus is measured in metres.

B The volume of a can of fizzy drink is measured in centilitres.

C The length of a football pitch is measured in yards.

D The mass of an elephant is measured in grams.

17 Three of the following statements are true and **one** is false. Which one is **false**?

- A $\frac{5}{7}$ is greater than 70%.
- B The original price of a washing machine was £448. After a 40% reduction its price is £320.
- C 0.56 is equivalent to $\frac{14}{25}$.
- D A graphical calculator costs £65 plus VAT at 20%. The price of the calculator including VAT is £78.

18 Three of the following statements are true and **one** is false. Which one is **false**?

- A The solution of $3a - 7 \leq 8$ is $a \leq 5$.
- B The solution of $4(x - 3) > 2(x + 5)$ is $x > 11$.
- C The solution of $2 - 3y > 7$ is $y > -\frac{5}{3}$.
- D The solution of $-5 < 3m - 2 < 4$ is $-1 < m < 2$.

19 Which **one** of the following is the **correct** algebraic expression for the following statement?

“I think of a number, multiply it by 4, then add 3, divide by 5 and subtract 7.”

A $\left(\frac{4x}{5} + 3\right) - 7$

B $\left(4x + \frac{3}{5}\right) - 7$

C $\left(\frac{4x+3}{5}\right) - 7$

D $4\left(\frac{x+3}{5}\right) - 7$

20 Ryszard made a scale model of a house on a scale of 5 cm : 1 m.

Three of the following conclusions are true and **one** is false. Which one is **false**?

A The height of the front door in his model is 9.5 cm, so the height of the front door in the house is 1.9 m.

B The volume of the kitchen in his model is 2475 cm^3 , so the volume of the kitchen in the house is 19.8 m^3 .

C The height of his model is 37.5 cm, so the height of the house is 7.5 m.

D The area of his bedroom floor in the model is 56.25 cm^2 , so the area of his bedroom floor in the house is 22.5 m^2 .

21 Two formulae have been rearranged.

X: $V = \pi r^2 h$ has been rearranged to give $h = \frac{V}{\pi r^2}$.

Y: $v^2 = u^2 + 2as$ has been rearranged to give $u = \pm \sqrt{v^2 + 2as}$.

Which **one** of the following statements is **true**?

- A X is correct and Y is incorrect.
- B Both X and Y are incorrect.
- C X is incorrect and Y is correct.
- D Both X and Y are correct.

22 Which **one** of the following is a correct simplification of $\frac{2+x}{4} - \frac{3-2x}{3}$?

- A $3x - 1$
- B $\frac{11x-6}{12}$
- C $-x - 1$
- D $\frac{-6-5x}{12}$

- 23 The cumulative frequency graph below summarises the marks gained in a religious studies test by a group of 80 students.

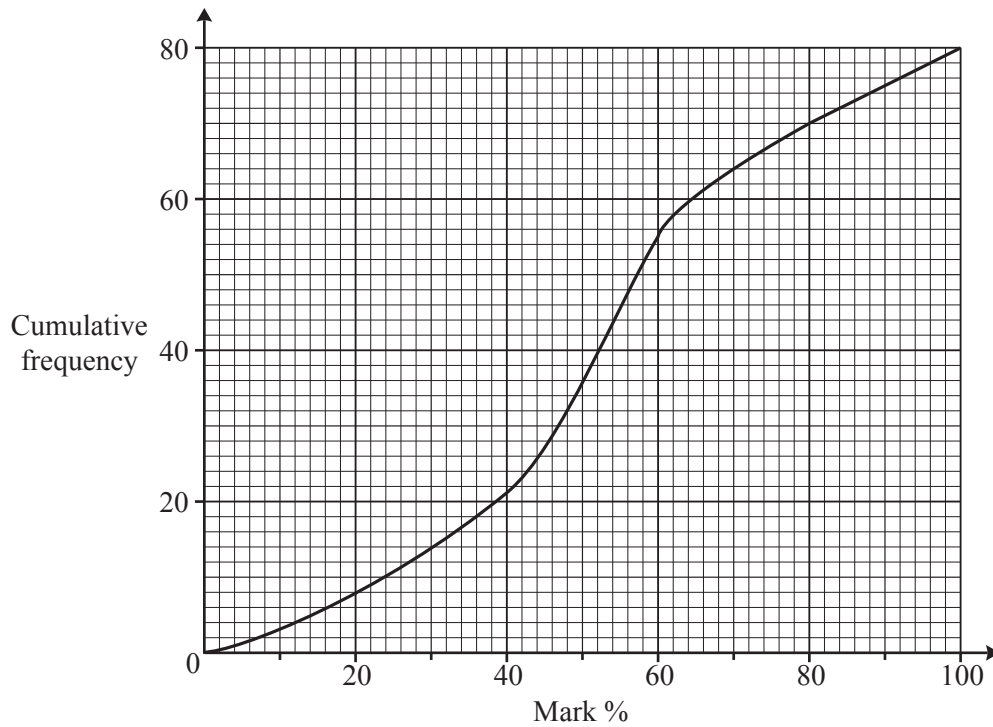

Three of the following statements are true and **one** is false. Which one is **false**?

- A The median mark is approximately 52%.
- B Approximately 16 students achieved a mark of less than 70%.
- C The lower quartile is approximately 38%.
- D Approximately 33 students achieved a mark between 40% and 60%.

- 24 You are given the simultaneous equations

$$4x + 3y = 16 \text{ and } 5x - y = 1.$$

Which **one** of the following statements is the **correct** solution?

- A $x = 4, y = -1$
- B $x = 1, y = -4$
- C $x = 4, y = -1$
- D $x = 1, y = 4$
- 25 The table below shows summarised data collected during one week by two taxi firms about their distances in miles on various journeys.

	Minimum	Lower quartile	Median	Upper quartile	Maximum
ABC Taxis	0.8	3.1	6.2	6.9	18.1
Smith's Taxis	1.2	4.6	7.1	11.6	29.3

Three of the following statements are true and **one** is false. Which one is **false**?

- A 75% of journeys by ABC Taxis were less than 3.1 miles.
- B The range of journeys for ABC Taxis was over 17 miles.
- C Half of the journeys of Smith's Taxis were more than 7.1 miles.
- D The interquartile range of journeys for ABC Taxis was less than the interquartile range for journeys of Smith's Taxis.

- 26 The cost, £ C , of hiring an electrician for n hours is given by the formula

$$C = 45 + 35n.$$

Three of the following statements are true and **one** is false. Which one is **false**?

- A Each extra hour's work increases the cost by £45.
- B The cost of 10 hours' work is £395.
- C A way of calculating the number of hours worked is to subtract 45 from C and divide by 35.
- D The graph below shows a representation of the formula.

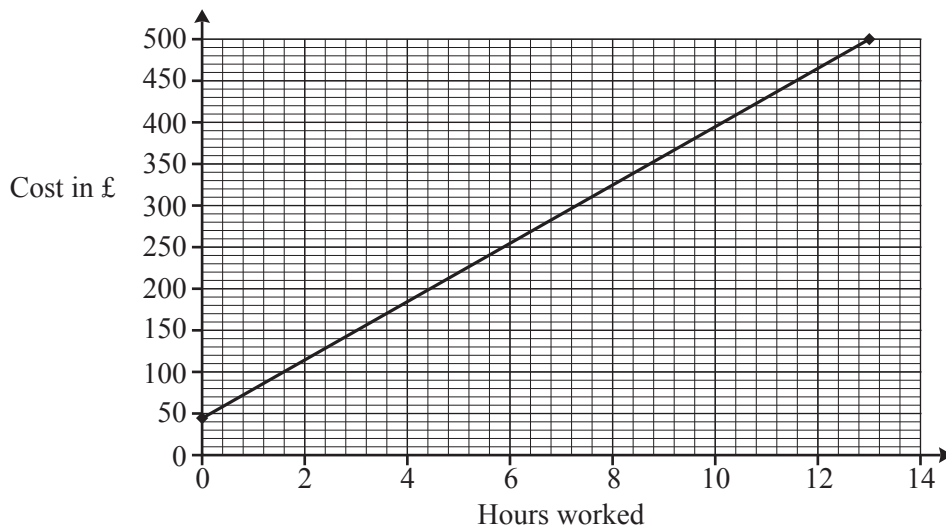

- 27 Three of the following statements are true and **one** is false. Which one is **false**?

- A The solution of $(2x - 3)(x + 5) = 2$ is $x = \frac{5}{2}$ or $x = -3$.
- B One of the roots of the equation $4x^2 = 9$ is $x = -1.5$.
- C $x = 5$ is the solution of the equation $5(2x - 3) - 3(x - 5) = 35$.
- D $x = 9$ is the solution of the equation $\frac{2x}{3} - 1 = 5$.

28 Which **one** of the following is the **correct** solution of the equation?

$$4M^2 = 3M + 9$$

A $M = -\frac{3}{8}(1 \pm \sqrt{15})$

B $M = \frac{3}{8}(1 \pm \sqrt{17})$

C $M = \frac{3}{8}(-1 \pm \sqrt{15})$

D $M = \frac{3}{8}(-1 \pm \sqrt{17})$

29 A motorcyclist rode a distance of 98 km, measured correct to the nearest 0.5 km, in a time of 1 h 5 min, measured correct to the nearest 1 min.

Which **one** of the following is the correct calculation for his **maximum** possible average speed in km/h?

A $97.75 \div \frac{65.5}{60}$

B $98.25 \div \frac{64.5}{60}$

C $97.75 \div \frac{64.5}{60}$

D $98.25 \div \frac{65.5}{60}$

30 Jayne made a 6-sided die. She rolled the die she had made 60 times. The table below shows her results.

Number shown on die	Frequency
1	9
2	1
3	10
4	9
5	20
6	11

Three of the following statements are true and **one** is false. Which one is **false**?

- A The data suggest that the probability of rolling a 5 is $\frac{1}{3}$.
- B The die appears to be biased.
- C The data suggest that the probability of rolling a number greater than 3 is $\frac{5}{6}$.
- D If Jayne rolled the die a total of 240 times, she would expect it to land on the number 1 approximately 36 times.

- 31 The diagram shows a cuboid ABCDEFGH. $AE = 12\text{ cm}$, $GH = 8\text{ cm}$, $EH = 10\text{ cm}$. M is the midpoint of CG.

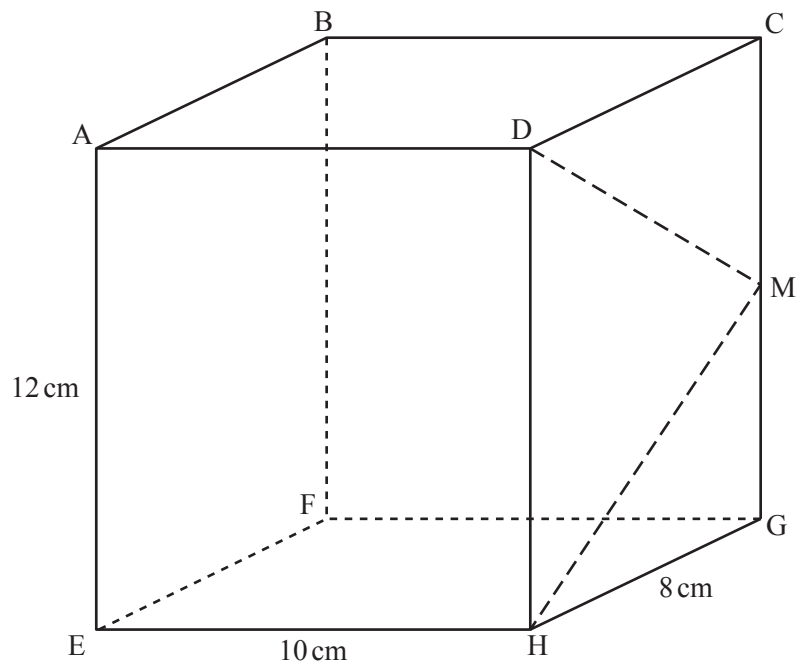

Three of the following statements are true and **one** is false. Which one is **false**?

- A The length of the base diagonal EG is $2\sqrt{41}\text{ cm}$.
- B The surface area of the cuboid is 592 cm^2 .
- C The angle, θ , that ED makes with EH is given by $\tan \theta = \frac{5}{6}$.
- D The area of triangle HMD = 48 cm^2 .

32 Three of the following statements are true and **one** is false. Which one is **false**?

A Given that $\tan \alpha = \frac{3}{4}$, then $\cos \alpha = \frac{3}{5}$.

B The following graph shows part of the curve of $y = 3 \cos x$.

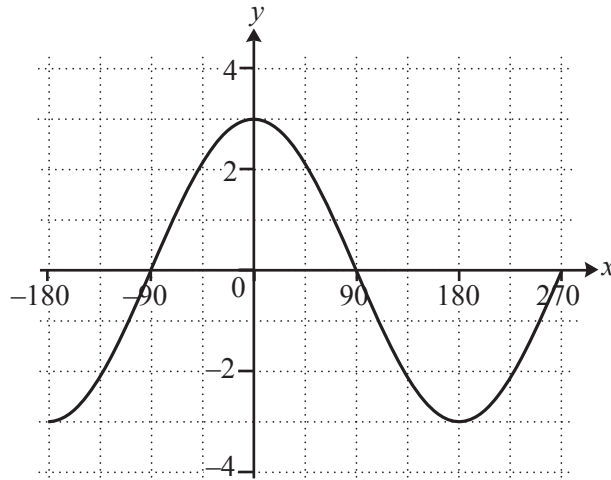

C One solution of $\sin \theta = -\frac{1}{2}$ is $\theta = 330^\circ$.

D The following graph shows part of the curve of $y = 2 + \tan x$.

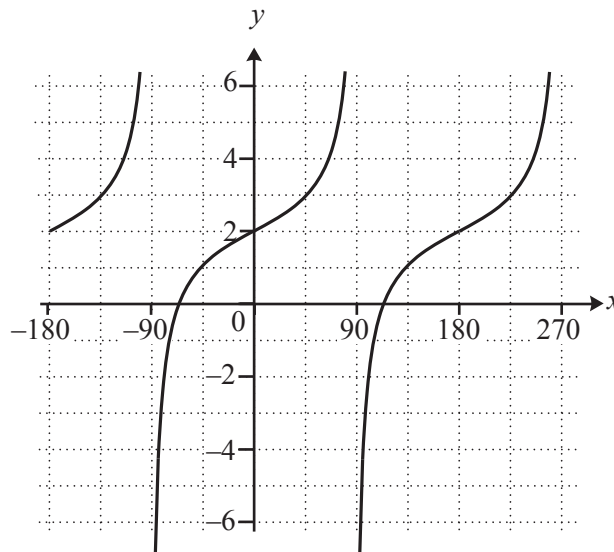

- 33 An open-top water tank in the shape of a cone is shown below. It has a height of 6 m and a diameter of 2 m.

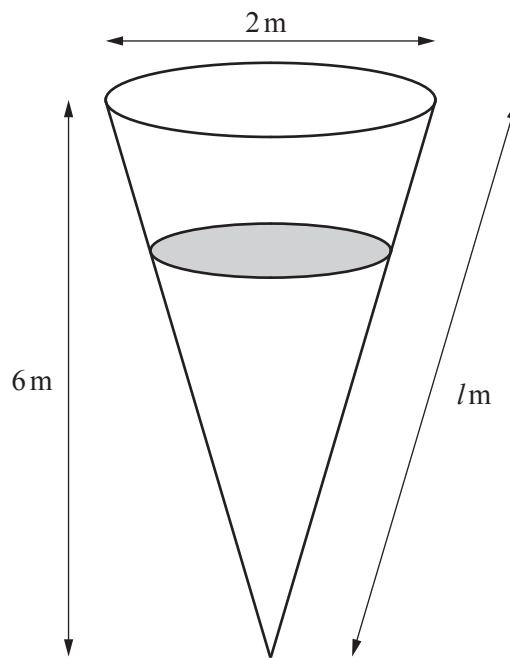

Three of the following statements are true and **one** is false. Which one is **false**?

- A For the tank, the ratio height : radius = 6 : 1.
- B The capacity of the tank is $2\pi \text{ m}^3$.
- C The curved surface area of the tank is 19.1 m^2 correct to 3 significant figures.
- D The volume of water in the tank is proportional to its depth.

- 34 The graph below shows the curve $y = x^2 + x - 5$.

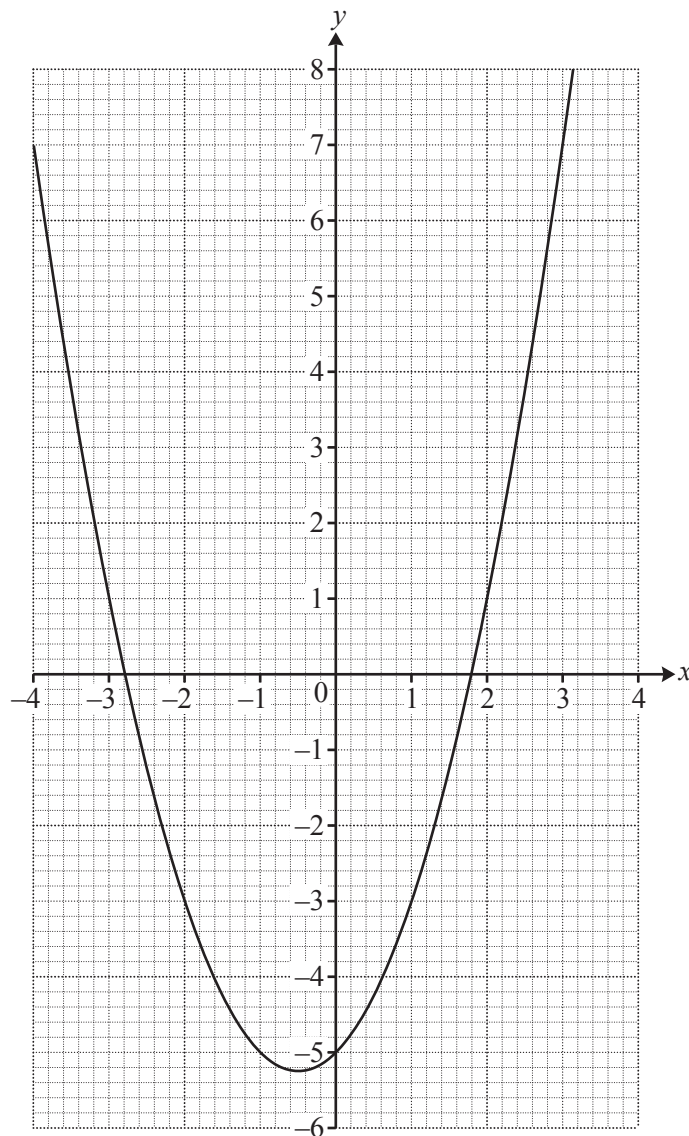

In order to answer this question you may find it helpful to draw the line $y = 2x + 1$ on the above grid.

Which **one** of the following is the **correct** pair of coordinates of the points of intersection of the curve and the line $y = 2x + 1$?

- A $(-7, -3)$ and $(2, 3)$.
- B $(-2, -3)$ and $(3, 7)$.
- C $(-3, -2)$ and $(7, 3)$.
- D $(-3, -7)$ and $(3, 2)$.

- 35 A bag contains 8 red discs and 5 blue discs. A disc is chosen from the bag at random and is **not** replaced. Another disc is then chosen.

In order to answer this question you are advised to complete the tree diagram.

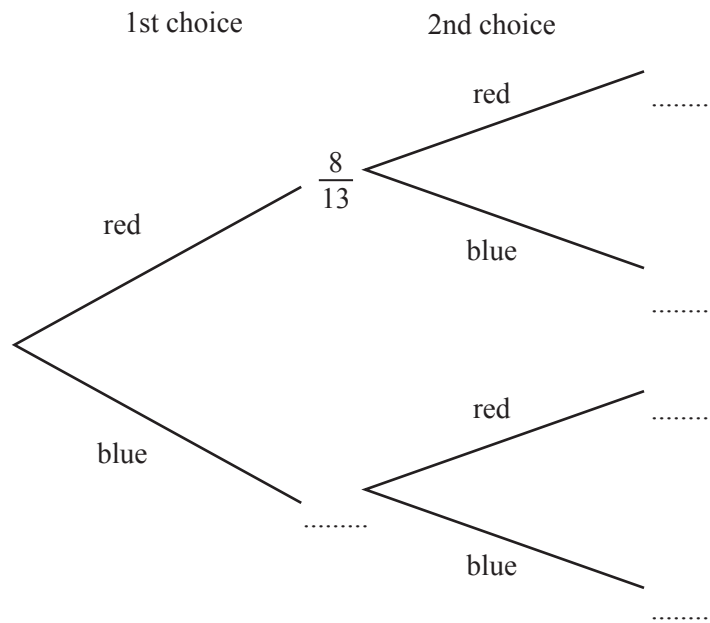

Three of the following statements are true and **one** is false. Which one is **false**?

- A The probability of choosing at least one red disc is $\frac{34}{39}$.
- B The probability of choosing two discs of the same colour is $\frac{20}{39}$.
- C The probability of **not** choosing two red discs is $\frac{25}{39}$.
- D The probability of choosing first a red disc and then a blue disc is $\frac{10}{39}$.

36 Three of the following statements are true and **one** is false. Which one is **false**?

A $3a^{-2} = \frac{1}{3a^2}$

B $(2x^2y)^4 = 16x^8y^4$

C $\frac{x^4 \times x^{-3}}{x^{-7}} = x^8$

D $7y^0 = 7$

37 To make concrete, the first step is to make a dry mixture of cement, sand and gravel in the ratio 1 : 2 : 2. Water is then added.

9 litres of water are added to every 20kg of the dry mixture. The mass of 1 litre of water is 1 kg.

Three of the following statements are true and **one** is false. Which one is **false**?

A 40% of the dry mixture is sand.

B 725 kg of concrete contains 225 litres of water.

C The ratio by mass of cement : sand : gravel : water = 4 : 8 : 8 : 9.

D 200 litres of water must be added to 90 kg of the dry mixture.

- 38 A small, light aircraft is flying with an air speed of 160 km h^{-1} . The pilot is steering due south from point A. B is 60 km due south of A. There is a crosswind from east to west of 30 km h^{-1} .

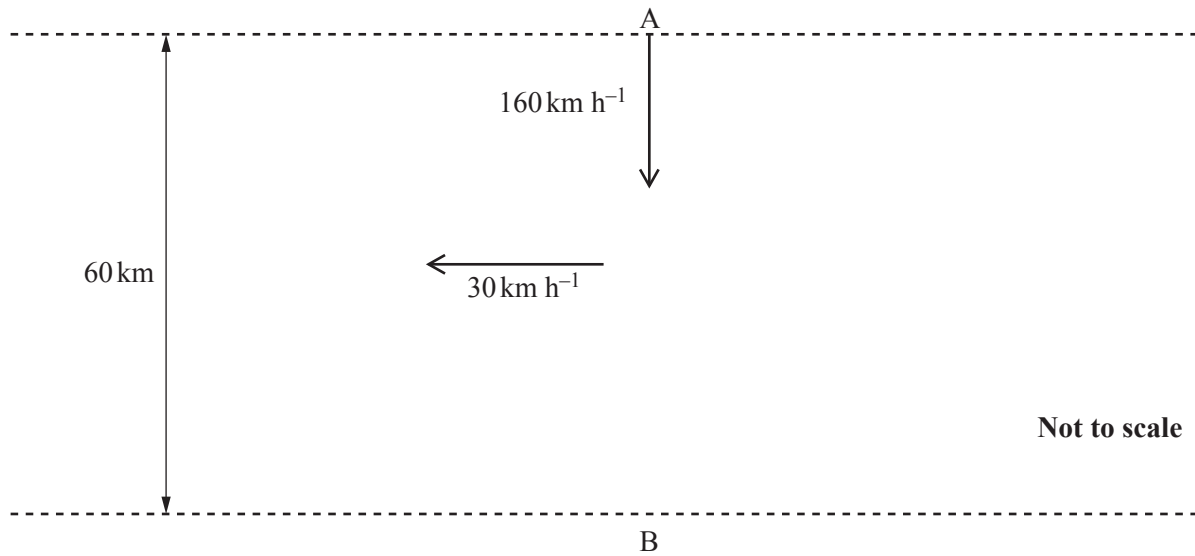

Three of the following statements are true and **one** is false. Which one is **false**?

- A The aircraft is actually flying on a bearing of 191° , correct to the nearest degree.
- B The actual speed of the aircraft is 163 km h^{-1} , correct to the nearest whole number.
- C If the pilot does not alter course, the aircraft will fly over a point 11.1 km due west of B, correct to 1 decimal place.
- D To fly directly to point B, the pilot must steer on a bearing of 169° , correct to the nearest degree.

39 The curve with equation $y = x^3 - 5x + 3$ is shown below.

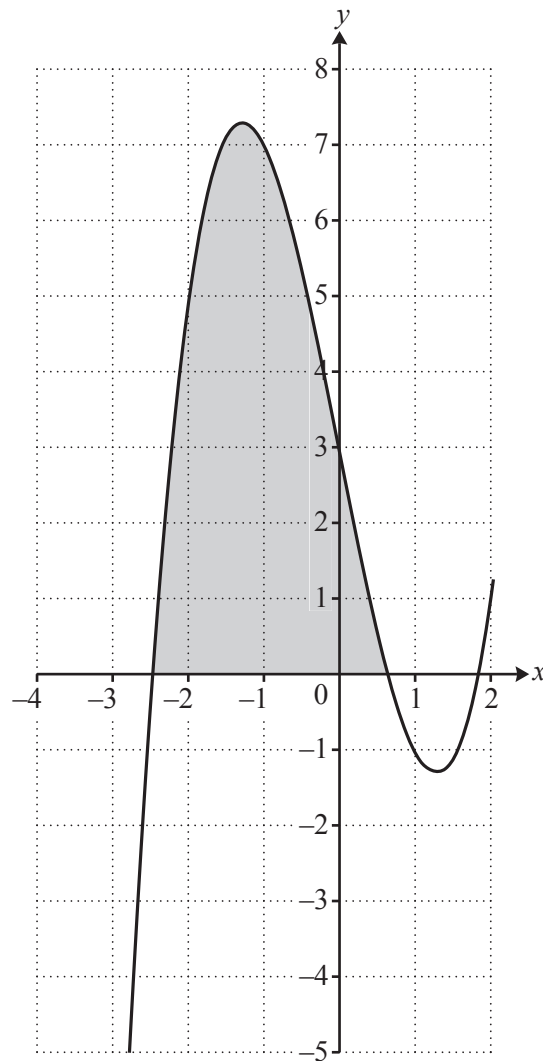

Three of the following statements are true and **one** is false. Which one is **false**?

- A The equation $x^3 - 5x + 3 = -4$ has a root in the range $-3 < x < -2$.
- B The gradient of the tangent to the curve when $x = -1$ is approximately 2.
- C The shaded area enclosed by the curve and the x -axis is between 12 and 16 units².
- D The equation $x^3 - 5x + 3 = 0$ has exactly three roots.

40 The isosceles triangle ABC is shown below.

$AB = BC = 5 \text{ cm}$, $AD = 7 \text{ cm}$ and angle $BAD = 30^\circ$.

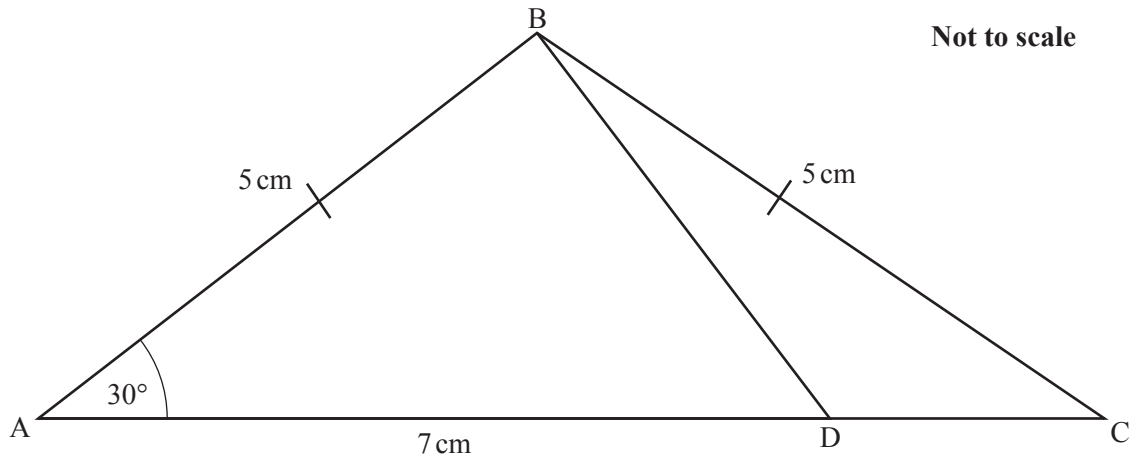

Which **one** of the following is the **correct** size of angle BDC, correct to 1 decimal place?

- A 143.1°
- B 136.9°
- C 134.1°
- D 163.9°

END OF QUESTION PAPER

OCR
Oxford Cambridge and RSA

Copyright Information

OCR is committed to seeking permission to reproduce all third-party content that it uses in its assessment materials. OCR has attempted to identify and contact all copyright holders whose work is used in this paper. To avoid the issue of disclosure of answer-related information to candidates, all copyright acknowledgements are reproduced in the OCR Copyright Acknowledgements Booklet. This is produced for each series of examinations and is freely available to download from our public website (www.ocr.org.uk) after the live examination series.

If OCR has unwittingly failed to correctly acknowledge or clear any third-party content in this assessment material, OCR will be happy to correct its mistake at the earliest possible opportunity.

For queries or further information please contact the Copyright Team, First Floor, 9 Hills Road, Cambridge CB2 1GE.

OCR is part of the Cambridge Assessment Group; Cambridge Assessment is the brand name of University of Cambridge Local Examinations Syndicate (UCLES), which is itself a department of the University of Cambridge.