

OCR

Oxford Cambridge and RSA

Thursday 8 June 2017 – Afternoon

AS GCE PHYSICS B (ADVANCING PHYSICS)

G492/01 Understanding Processes/Experimentation and Data Handling

Duration: 2 hours

ADVANCE NOTICE



INSTRUCTIONS TO CANDIDATES

- Take the article away and read through it carefully. Spend some time looking up any technical terms or phrases you do not understand. You might find it helpful to try out the measurement ideas described in part 3.
- For the examination on Thursday 8 June 2017 you will be given a fresh copy of this article, together with a question paper. You will not be able to take your original copy into the examination with you.
- The values of standard physical constants will be given in the Advancing Physics Data, Formulae and Relationships booklet. Any additional data required are given in the appropriate question.

INFORMATION FOR CANDIDATES

- Questions in Section C of paper G492/01 (Understanding Processes, Experimentation and Data Handling) will refer to this Advance Notice material and may give additional data related to it.
- Section C will be worth about 40 marks.
- Sections A and B of paper G492/01 will be worth about 60 marks, and will examine the *Understanding Processes* section of the specification.
- There will be 2 marks for quality of written communication (QWC) assessed in Sections B and C.
- This document consists of 4 pages. Any blank pages are indicated.

1 Uncertainty in a calculated result

When thinking about the uncertainty in an experiment, you need to consider the uncertainty in every measurement. It is important to identify the most uncertain measurement, because this is the measurement which will be most worthwhile improving. Also, this uncertainty is the one which contributes most to the uncertainty of the final result. Fig. 1 shows a chart of repeated measurements of the breaking force of samples of the same cotton thread.

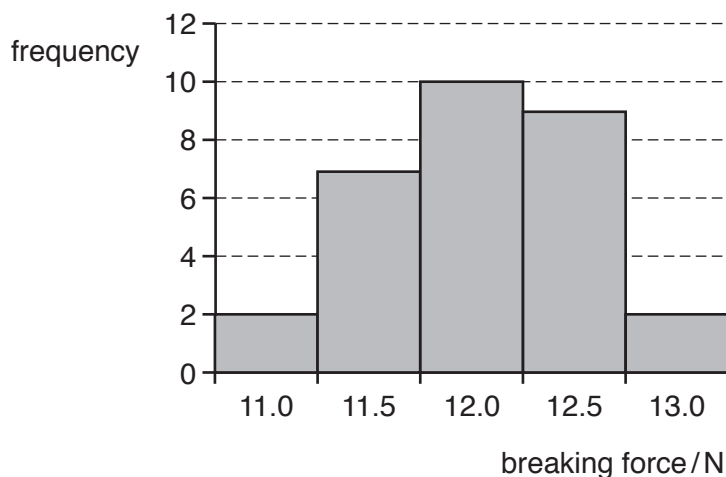

Fig. 1

There are no outliers in this data, and you can easily find the mean of the 30 measurements, which is 12.0 N. The spread (half the range) is 1 N, so the value is (12 ± 1) N, giving a percentage uncertainty of 8%.

Measuring the diameter of the same cotton thread with a micrometer shows that the diameter measurement is less variable than that of the breaking force, so you can get a minimum estimate of the variation in breaking stress from the variation in breaking force.

In this case, the diameter of the thread is 0.24 mm (2.4×10^{-4} m), giving a cross-sectional area of 4.5×10^{-8} m², so the breaking stress can be easily calculated for the maximum and minimum values of breaking force. This allows calculation of the mean breaking stress and also an estimate of its uncertainty.

Copyright Information

OCR is committed to seeking permission to reproduce all third-party content that it uses in its assessment materials. OCR has attempted to identify and contact all copyright holders whose work is used in this paper. To avoid the issue of disclosure of answer-related information to candidates, all copyright acknowledgements are reproduced in the OCR Copyright Acknowledgements Booklet. This is produced for each series of examinations and is freely available to download from our public website (www.ocr.org.uk) after the live examination series.

If OCR has unwittingly failed to correctly acknowledge or clear any third-party content in this assessment material, OCR will be happy to correct its mistake at the earliest possible opportunity.

For queries or further information please contact the Copyright Team, First Floor, 9 Hills Road, Cambridge CB2 1GE.

OCR is part of the Cambridge Assessment Group; Cambridge Assessment is the brand name of University of Cambridge Local Examinations Syndicate (UCLES), which is itself a department of the University of Cambridge.

2 Spectacles for the Third World

Many charities collect unwanted spectacle lenses for reuse in the Third World. The power of these lenses varies from +5D (converging) to -5D (diverging), with the majority being in the latter category. There is a need for a quick and easy-to-use method of measuring the power of these lenses when they arrive at their destination, using appropriate technology and expertise.

Measurement of the power of a converging lens is fairly straightforward. All you need is a beam of parallel light, a piece of stiff white card and a ruler, as shown in Fig. 2.

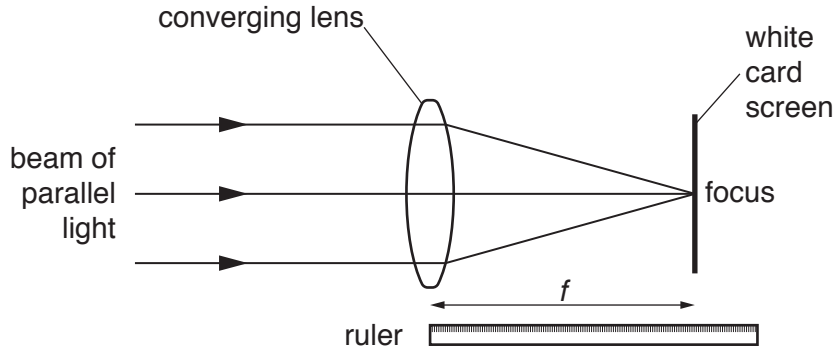

Fig. 2

This method does not work for a diverging lens. This is because the light which leaves the lens appears to come from a point behind it, where you cannot put a screen to find the focus, as shown in Fig. 3.

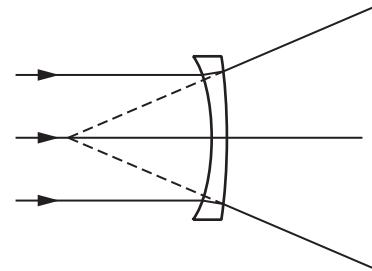

Fig. 3

The way that a diverging lens *can* be made to focus light to a point on a screen is to use a converging lens to arrange for the incoming light beam to be already aiming to a focus, as shown in Fig. 4.

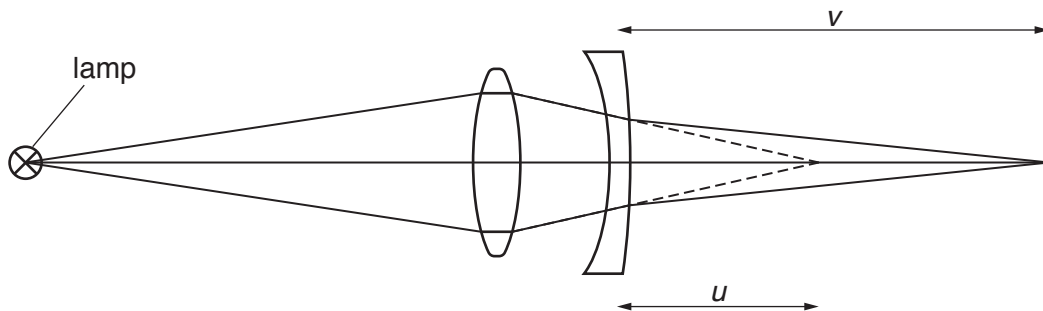

Fig. 4

A charity appoints an engineer, Melanie Brown, to design a simple method for use in the Third World to measure the power of diverging spectacle lenses. She uses the arrangement shown in Fig. 4 and follows this procedure:

- With both lenses in place, measure the distance from the diverging lens to the position of the screen where the light is focused. This is the image distance, v .
- Remove the diverging lens, and move the screen until the light is focused by the converging lens alone. The distance from where the diverging lens was placed to the new screen position is the object distance, u .

3 Measuring the Planck constant using LEDs

You may wish to try out this experiment in the laboratory so that you will know in advance how the experiment works, what the difficulties are and how the data can be processed. The quantisation of light as discrete packets of energy called photons can be explored experimentally using LEDs in a circuit such as that shown in Fig. 5.

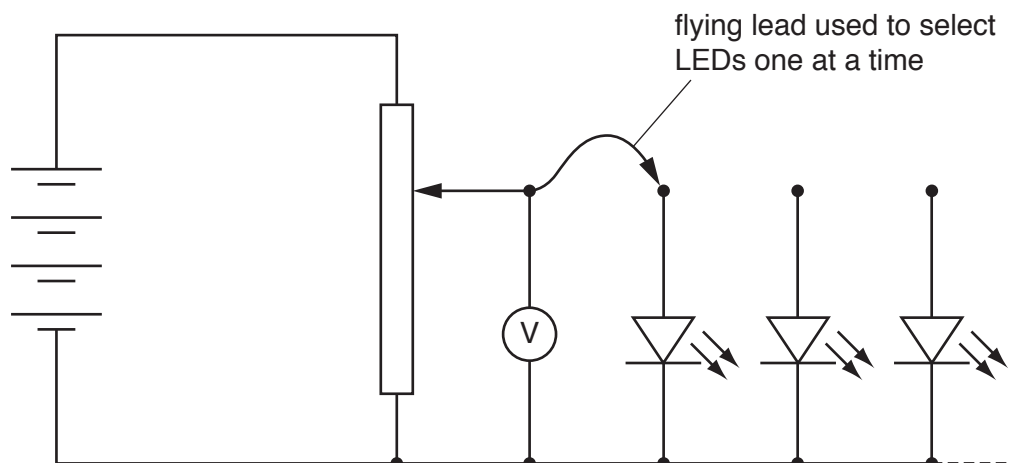

Fig. 5

The potential difference (p.d.) across the LED is gradually increased until it emits photons (strikes). The p.d. at which the LED just emits photons is known as the striking voltage V_s .

Each electron of charge e 'falling through' a p.d. V_s releases energy $E = V_s e$ as a single photon of light. The most significant uncertainties in this experiment are associated with consistently and accurately judging the voltage at which the LED strikes. To allow the strike to be detected with greater sensitivity, it is usual to shield the LED with a small opaque paper tube down which the observer can peer at the LED.

Data from one such experiment are shown in the table below.

LED colour	λ/nm	average V_s/V
deep red	641	1.94
red	627	1.98
orange	609	2.04
green	574	2.17
turquoise	494	2.52
blue	468	2.66
violet	411	3.02

Plotting an appropriate graph of the data obtained from the experiment allows a value for the Planck constant to be determined.

END OF ARTICLE