

Tuesday 24 May 2016 – Morning

GCSE DESIGN AND TECHNOLOGY: ELECTRONICS AND CONTROL SYSTEMS

A515/02 Sustainability and technical aspects of designing and making –
Pneumatics

Candidates answer on the Question Paper.

OCR supplied materials:

None

Other materials required:

- A calculator may be used for this paper.
- Pencil
- Ruler (cm/mm)

Duration: 1 hour 30 minutes



Candidate forename		Candidate surname	
-----------------------	--	----------------------	--

Centre number						Candidate number				
---------------	--	--	--	--	--	------------------	--	--	--	--

INSTRUCTIONS TO CANDIDATES

- Write your name, centre number and candidate number in the boxes above. Please write clearly and in capital letters.
- Use black ink. HB pencil may be used for graphs and diagrams only.
- Answer **all** the questions in Section A **and** Section B.
- Read each question carefully and make sure that you know what you have to do before starting your answer.
- Write your answer to each question in the space provided. If additional space is required, you should use the lined page(s) at the end of this booklet. The question number(s) must be clearly shown.
- Do **not** write in the bar codes.
- Show all working out for calculations.

INFORMATION FOR CANDIDATES

- The number of marks for each question is given in brackets [] at the end of the question or part question.
- The total number of marks for this paper is **80**.
- Your quality of written communication is assessed in questions marked with an asterisk (*).
- Dimensions are in millimetres unless stated otherwise.
- This document consists of **20** pages. Any blank pages are indicated.

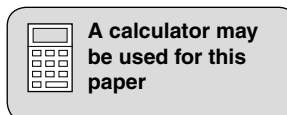

SECTION A

Answer **all** the questions.

You are advised to spend 40 minutes on this section

On questions 1–5 **circle** your answer.

- 1** Fitting thermal insulation glass to a house:
- (a) Lets in double the light
 - (b) Re-uses glass from another house
 - (c) Increases passive solar gain
 - (d) Helps keep the loft warm [1]
- 2** Assessing potential dangers in an electronics factory is called:
- (a) Making eco-friendly products
 - (b) Undertaking a risk assessment
 - (c) Complying with the fair trade initiative
 - (d) Cooling an electronic hot spot [1]
- 3** Approaching a problem differently is:
- (a) Repetition
 - (b) Reversal
 - (c) Afterthought
 - (d) Rethinking [1]
- 4** Eco-design is used when designing a product to make it:
- (a) As environmentally friendly as possible
 - (b) Easy to manufacture as quickly as possible
 - (c) Usable anywhere in the world
 - (d) Make as much money as possible [1]
- 5** In the 6Rs, 'Reduce' refers to:
- (a) Making a product easy to disassemble
 - (b) Accepting lower profits
 - (c) Using fewer materials
 - (d) Lowering delivery charges [1]

- 6 Name **one** smart material that can shorten its length when electrically heated.
..... [1]
- 7 State why lead should not be used in electronic products.
..... [1]
- 8 Give **one** reason why video-conferencing on the internet can reduce your carbon footprint.
.....
..... [1]
- 9 State the meaning of the term 'sweatshop'.
..... [1]
- 10 Name **one** plastic made from oil.
..... [1]

Decide whether the statements below are **true** or **false**.

Tick [✓] the box to show your answer.

- | | True | False | |
|---|--------------------------|--------------------------|-----|
| 11 Geothermal power generation contributes to global warming. | <input type="checkbox"/> | <input type="checkbox"/> | [1] |
| 12 Renewable resources are in limited supply. | <input type="checkbox"/> | <input type="checkbox"/> | [1] |
| 13 CFCs improve the ozone layer. | <input type="checkbox"/> | <input type="checkbox"/> | [1] |
| 14 The Ethical Trading Initiative is global. | <input type="checkbox"/> | <input type="checkbox"/> | [1] |
| 15 Environmentally friendly packaging decomposes naturally. | <input type="checkbox"/> | <input type="checkbox"/> | [1] |

16 Fig. 1 shows an MP3 speaker unit in closed and open positions.

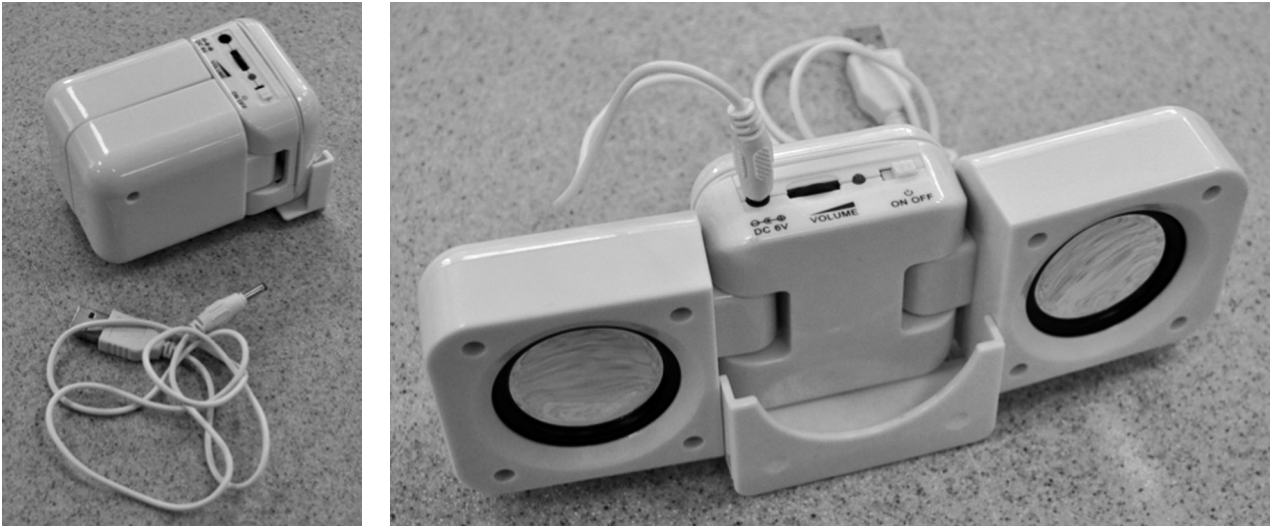

Fig. 1

(a) Identify **three** design features of the MP3 speakers shown in Fig. 1.

- 1
-
- 2
-
- 3
-

[3]

(b) The MP3 speakers can be powered from either a USB socket or from internal batteries.

Give **two** benefits of using the USB power source.

- 1
-
- 2
-

[2]

PLEASE DO NOT WRITE ON THIS PAGE

Turn over for the next question

(c) An MP3 speaker unit is to be made from recycled components.

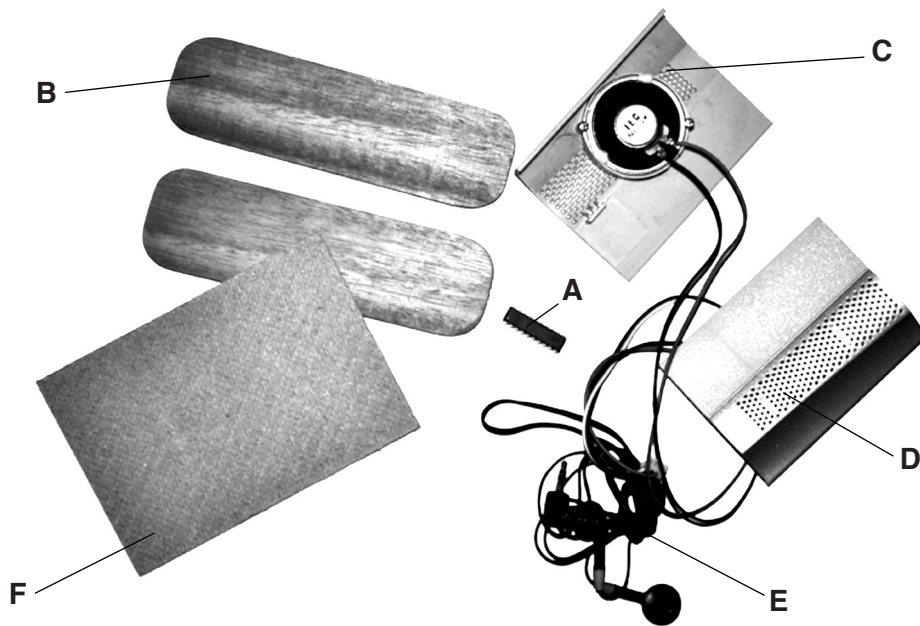

Fig. 2

Fig. 2 shows the parts collected.

Identify the parts from Fig. 2, and complete the table below with the correct description. One has been done for you.

Name of part	Letter on Fig. 2
Integrated Circuit (IC) audio amplifier	A
Loudspeaker from PC monitor	
MP3 player earphone lead with broken earphones	
Piece of hardboard salvaged from back of a cupboard	
Speaker grill from broken PC monitor	
Tropical hardwood from old school bench	

[5]

(d) Use sketches and notes to design an MP3 speaker unit using the parts shown in Fig. 2.

[4]

BLANK PAGE

PLEASE DO NOT WRITE ON THIS PAGE

Turn over for the next question

10
SECTION B

Answer **all** the questions.

You are advised to spend 50 minutes on this section

- 17 Fig. 3 shows a pneumatically controlled target for a fairground shooting range. The target is positioned by cylinders **A**, **B** and **C**. Attempts to hit the target can be made once it appears above the screen.

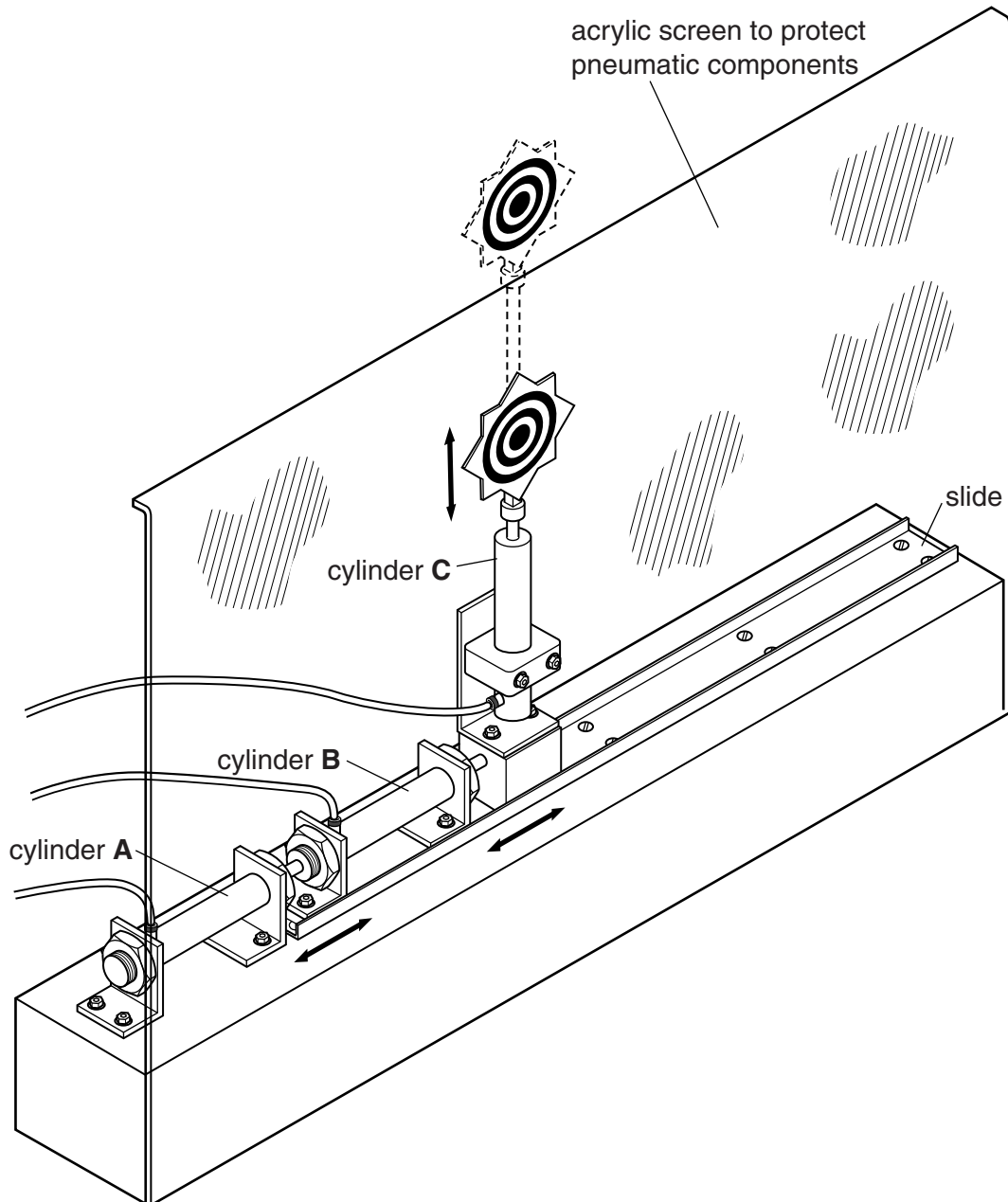
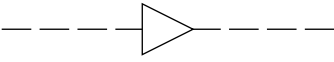



Fig. 3

- (a) The table below shows the component name and the symbol for some of the components available for making the pneumatically controlled target.

Complete the table by drawing in the missing symbols and adding the missing name.

Component name	Component symbol	
A		[1]
B reservoir		[1]
C shuttle valve		[2]

- (b) Fig. 4 shows one of the components used in a prototype version of the target.



Fig. 4

- (i) State the full name of the component.
- [1]
- (ii) Give **one** reason for the ball end being used on a general purpose component intended for a prototype circuit.
-
- [1]

(iii) Explain why the ball end would **not** be suitable for use in the pneumatic circuit for the target shown in Fig. 3.

.....

.....

.....

..... [2]

(c) Fig. 5 shows part of the circuit for the target.
Name **two** tools that would be needed during the assembly of the circuit.

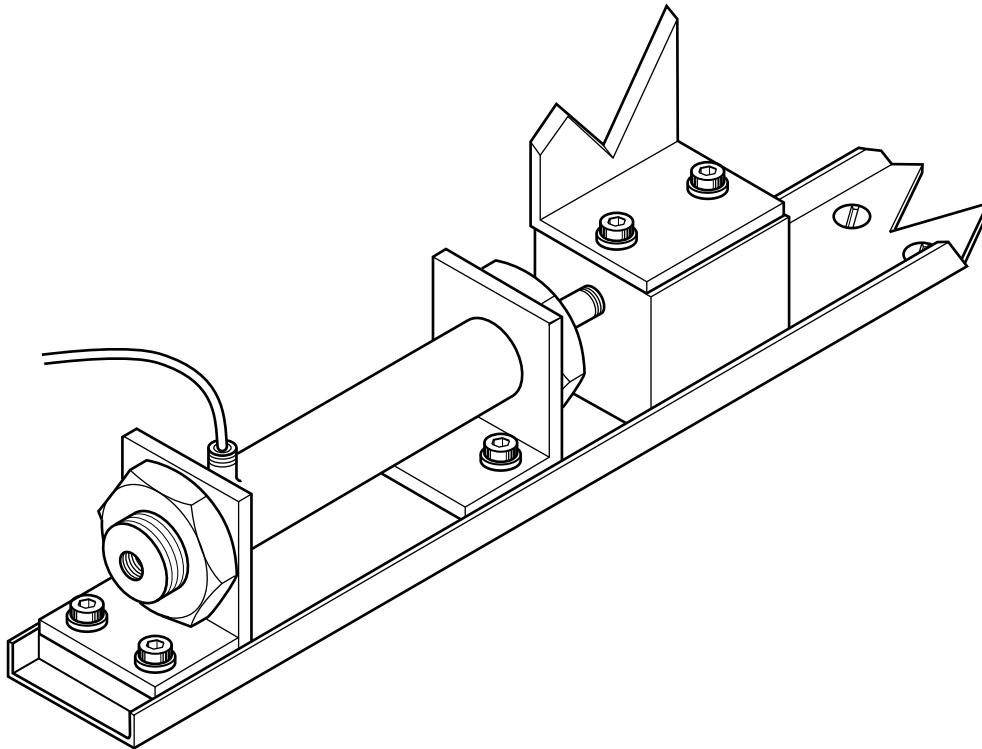

Fig. 5

1

2

[2]

(d) List **three** checks that should be done before turning on a pneumatic system for the first time.

- 1
-
- 2
-
- 3
-

[3]

(e) When air is compressed, an unwanted by-product is produced.

(i) State the name of the by-product.

..... [1]

(ii) Give **one** reason why the by-product is not wanted in the system.

..... [1]

18 (a) Fig. 6 shows an incomplete prototype circuit for the fairground shooting target.

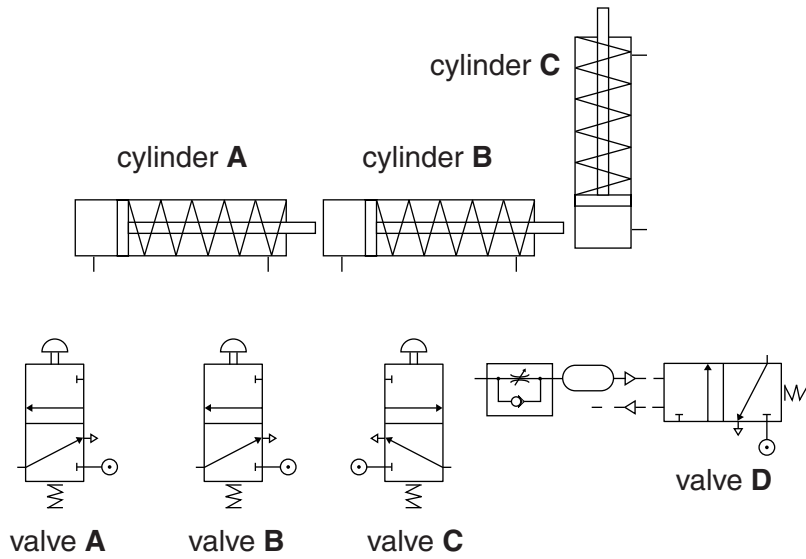

Fig. 6

(i) Complete the circuit in Fig. 6 so that:

- cylinder **A** will outstroke when valve **A** is pressed
- cylinder **B** will outstroke when valve **B** is pressed
- cylinder **C** will outstroke a short time after valve **C** is pressed. [3]

(ii) Explain how the time delay between valve **C** being pressed and cylinder **C** outstroking is achieved.

.....

 [3]

(b) The target can appear in three different horizontal positions.

Complete the table below to show the state of valves **A** and **B** for each position of the target. The valve state should be shown as 'pressed' or 'not pressed'.

	position 1	position 2	position 3
valve A			
valve B			

[3]

- (c)* Discuss the factors that should be considered when designing and assembling a control system.

.....
.....
.....
.....
.....
.....
.....
.....
.....
.....
.....
.....
.....
.....
.....
.....
.....
.....
.....
.....
.....
.....
.....
.....
.....

..... [6]

19 After the prototype circuit in Fig. 6 had been tested, the designers decided to add a programmable control system for the cylinder operation.

Valves **A**, **B** and **C** were replaced by 3/2 solenoid spring return valves operated by the programmable controller, as shown in Fig. 7.

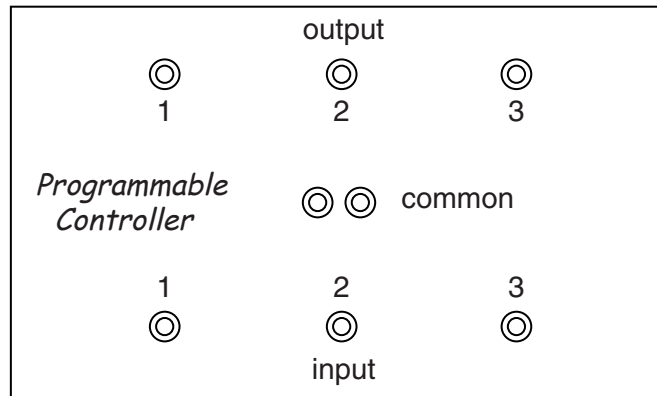
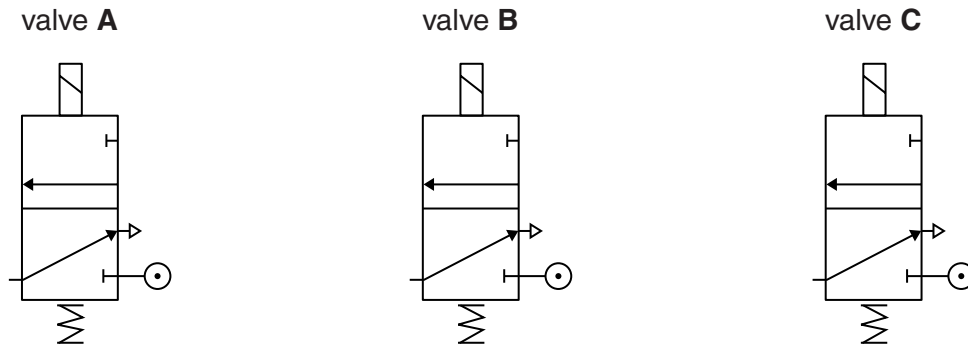

Fig. 7

(a) (i) Add the electrical connections to Fig. 7 to allow the valves to be operated. [3]

(ii) Fig. 8 shows the valve used.

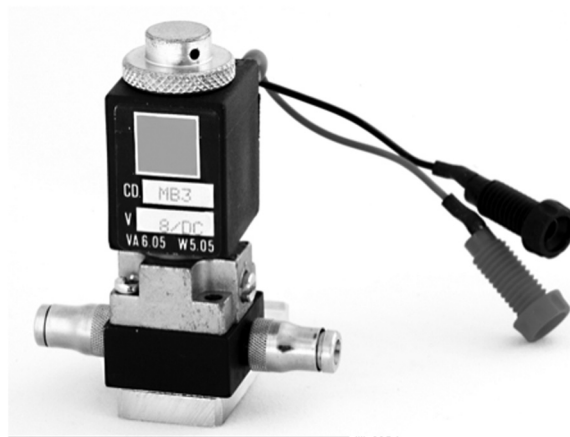

Fig. 8

When the system was tested, valve **B** would not operate.
Describe the tests that should be done to identify the fault.

.....

.....

.....

.....

.....

.....

..... [3]

(b) The programmable controller in Fig. 7 sends a random signal to valve **A** and valve **B** to position the target horizontally. At the same time a signal is sent to valve **C** to raise the target.

Give **two** advantages of using a computer control system rather than manual control.

1

.....

2

.....

[2]

- (c) The programmable controller needs a feedback signal to indicate when cylinder **C** is fully outstroked.
 The feedback signal is given when a microswitch contacts the acrylic screen, as shown in Fig. 9.

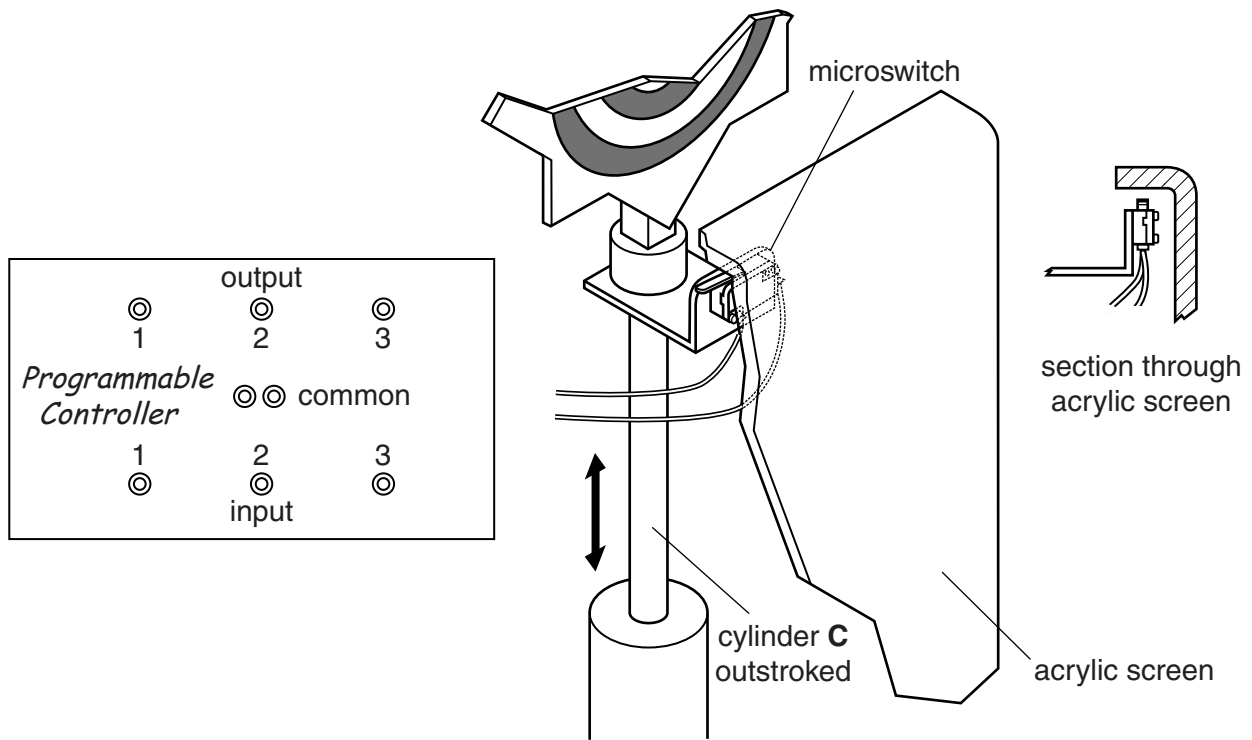

Fig. 9

On Fig. 9 add the connections from the microswitch to the programmable controller. [2]

- (d) Describe how the bend at the top of the acrylic screen could be formed.

.....

.....

..... [2]

- (e) The operating force for cylinder **A** and all that is attached to it is 50 N.
 The diameter of cylinder **A** is 25 mm.
 Calculate the pressure that the system must supply.

Use the formula $F = P \times A$

.....

.....

.....

.....

..... [3]

END OF QUESTION PAPER

ADDITIONAL ANSWER SPACE

If additional space is required, you should use the following lined page(s). The question number(s) must be clearly shown in the margins.

A large area of lined paper for writing answers. It features a vertical margin line on the left side and horizontal dotted lines for writing. The lines are evenly spaced and extend across the width of the page.

A large area of the page is reserved for writing, featuring a vertical margin line on the left and horizontal dotted lines for writing.



Copyright Information

OCR is committed to seeking permission to reproduce all third-party content that it uses in its assessment materials. OCR has attempted to identify and contact all copyright holders whose work is used in this paper. To avoid the issue of disclosure of answer-related information to candidates, all copyright acknowledgements are reproduced in the OCR Copyright Acknowledgements Booklet. This is produced for each series of examinations and is freely available to download from our public website (www.ocr.org.uk) after the live examination series.

If OCR has unwittingly failed to correctly acknowledge or clear any third-party content in this assessment material, OCR will be happy to correct its mistake at the earliest possible opportunity.

For queries or further information please contact the Copyright Team, First Floor, 9 Hills Road, Cambridge CB2 1GE.

OCR is part of the Cambridge Assessment Group; Cambridge Assessment is the brand name of University of Cambridge Local Examinations Syndicate (UCLES), which is itself a department of the University of Cambridge.