

Friday 4 November 2016 – Morning

GCSE MATHEMATICS A

A503/01 Unit C (Foundation Tier)

Candidates answer on the Question Paper.

OCR supplied materials:

None

Other materials required:

- Scientific or graphical calculator
- Geometrical instruments
- Tracing paper (optional)

Duration: 1 hour 30 minutes



Candidate forename		Candidate surname	
--------------------	--	-------------------	--

Centre number						Candidate number				
---------------	--	--	--	--	--	------------------	--	--	--	--

INSTRUCTIONS TO CANDIDATES

- Write your name, centre number and candidate number in the boxes above. Please write clearly and in capital letters.
- Use black ink. HB pencil may be used for graphs and diagrams only.
- Answer **all** the questions.
- Read each question carefully. Make sure you know what you have to do before starting your answer.
- Your answers should be supported with appropriate working. Marks may be given for a correct method even if the answer is incorrect.
- Write your answer to each question in the space provided. Additional paper may be used if necessary but you must clearly show your candidate number, centre number and question number(s).
- Do **not** write in the bar codes.

INFORMATION FOR CANDIDATES

- The number of marks is given in brackets [] at the end of each question or part question.
- Your quality of written communication is assessed in questions marked with an asterisk (*).
- Use the π button on your calculator or take π to be 3.142 unless the question says otherwise.
- The total number of marks for this paper is **100**.
- This document consists of **20** pages. Any blank pages are indicated.

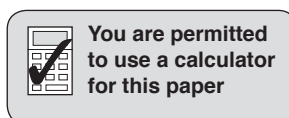

Formulae Sheet: Foundation Tier

Area of trapezium = $\frac{1}{2} (a + b)h$

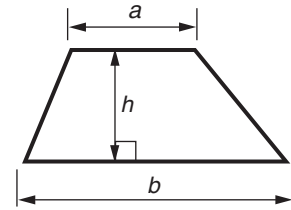

Volume of prism = (area of cross-section) \times length

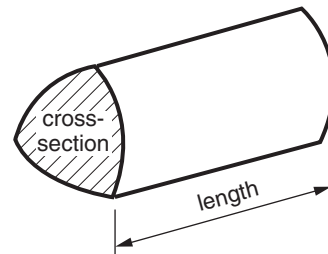

PLEASE DO NOT WRITE ON THIS PAGE

Answer **all** the questions.

- 1 (a) The thermometer shows the temperature in London on one day.

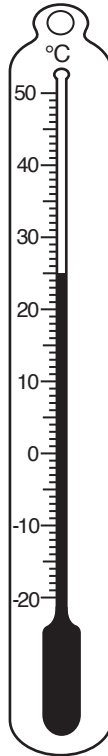

- (i) What temperature is shown on the thermometer?

(a)(i) _____ °C [1]

- (ii) On the same day, the temperature in Port Stanley was -10°C .

How much warmer was it in London than in Port Stanley?

(ii) _____ °C [1]

- (b) On the next day, the temperature in Port Stanley went up by 6°C .
What was the temperature in Port Stanley on the next day?

(b) _____ °C [1]

- 2 (a) The values in the squares must **add** to give the value in the circle.

Complete each of these.

(i)

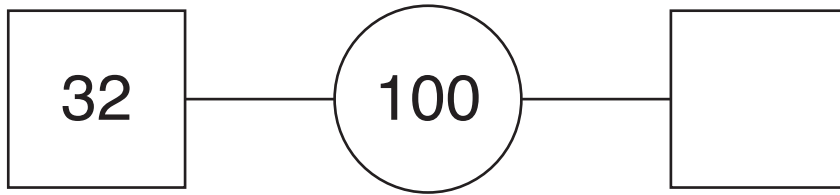

[1]

(ii)

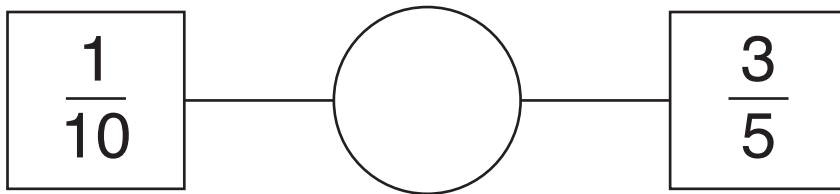

[1]

(iii)

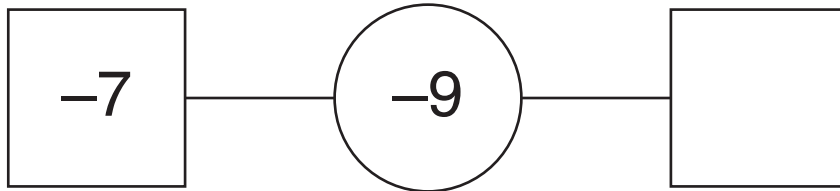

[1]

- (b) The values in the squares must **multiply** to give the value in the circle.

Complete each of these.

(i)

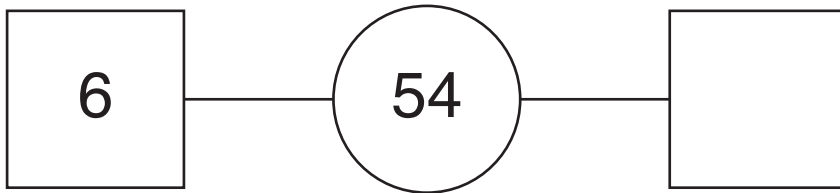

[1]

(ii)

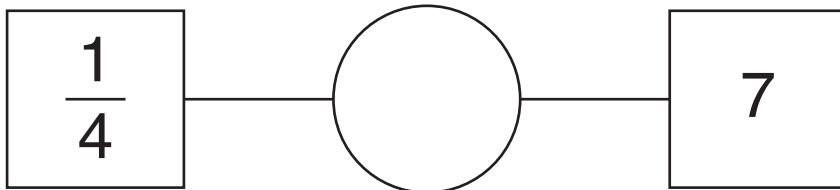

[1]

(iii)

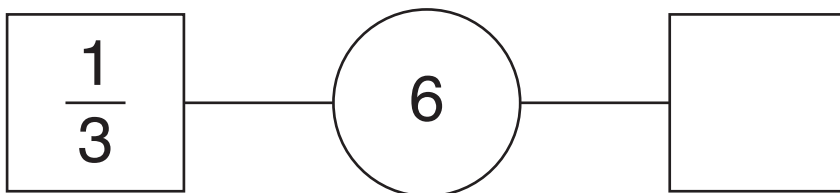

[1]

- 3 This net makes a 3-D shape when it is folded.

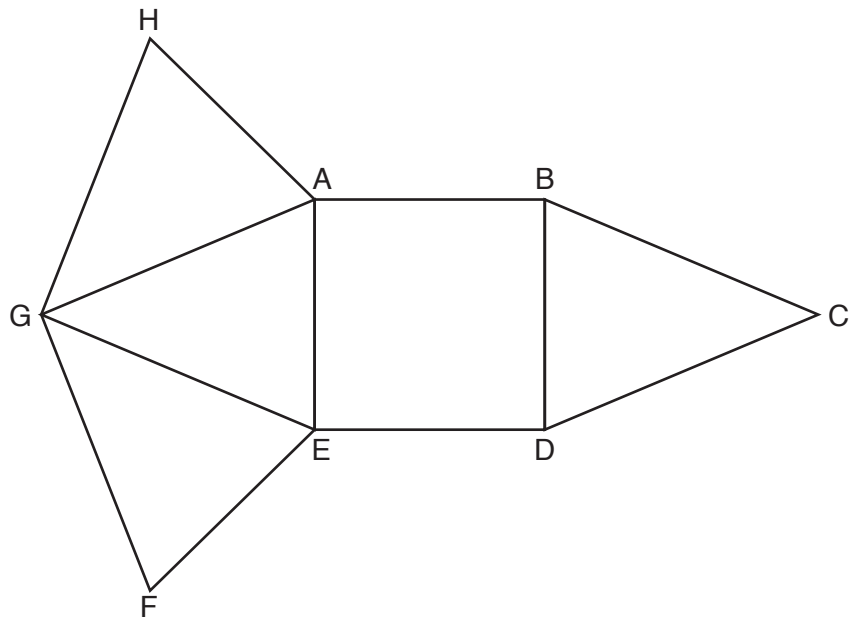

- (a) What is the name of the 3-D shape?

(a) _____ [1]

- (b) Write down the number of faces and the number of edges of the 3-D shape.

(b) number of faces _____

number of edges _____ [2]

- (c) Which point on the net will join to G when the 3-D shape is made?

(c) _____ [1]

- 4 Hamza buys chocolate bars costing £2.15 each.

What is the largest number of these chocolate bars he can buy with £20?
How much money will be left over?

_____ chocolate bars with _____ left over [3]

5

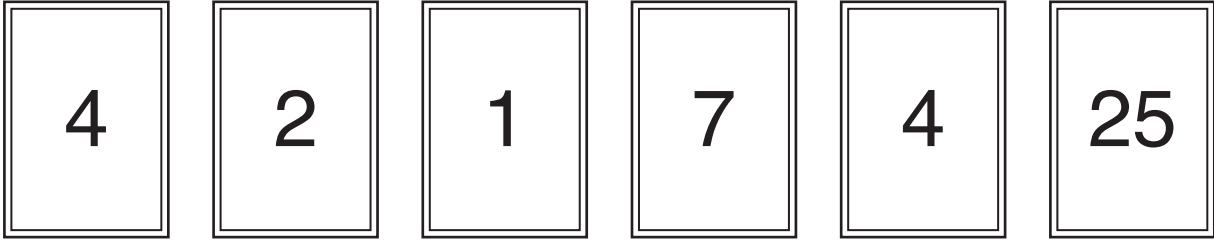

Nick plays a game with these number cards.
He picks one of the cards at random.

(a) Use one word from the box to complete each sentence.

impossible	certain	unlikely	evens	likely
------------	---------	----------	-------	--------

(i) It is _____ that Nick picks a number greater than 1. [1]

(ii) It is _____ that Nick picks an odd number. [1]

(iii) It is _____ that Nick picks a negative number. [1]

(b) Nick **removes** the 1 card and the 25 card and then **replaces** them with two other number cards.

He now picks a card at random.

- The probability that he will pick an odd number is $\frac{1}{2}$.
- The probability that he will pick a number less than 10 is 1.

Write down a possible number on each of the two replacement cards.

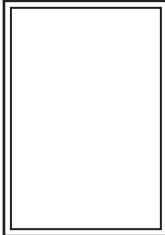
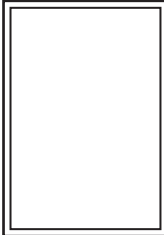
(b)  and  [2]

6 (a) Complete the following.

(i) $350 \text{ cm} = \underline{\hspace{2cm}} \text{ m}$ [1]

(ii) $0.023 \text{ km} = \underline{\hspace{2cm}} \text{ m}$ [1]

(b) The mass of an apple is 125 g.
The mass of a watermelon is 2.4 kg.

How much heavier is the watermelon than the apple?
Give the units of your answer.

(b) $\underline{\hspace{2cm}}$ [2]

(c) (i) Write 34.7 kg correct to the nearest kilogram.

(c)(i) $\underline{\hspace{2cm}}$ kg [1]

(ii) Write 7.82 m correct to one decimal place.

(ii) $\underline{\hspace{2cm}}$ m [1]

(iii) Write £3269 correct to one significant figure.

(iii) £ $\underline{\hspace{2cm}}$ [1]

7 You are given that $p = 3$, $t = 5$ and $r = 7$.

(a) Find the value of

(i) $4p$,

(a)(i) _____ [1]

(ii) t^2 .

(ii) _____ [1]

(b) The expression $p + 2t - r$ has a value of 6.

Write an expression using p , t and r that has a value of 1.

(b) _____ [2]

8 Gareth earns £240 each week.

(a) He spends $\frac{1}{8}$ of this money on his car.

(i) Work out how much he spends on his car.

(a)(i) £ _____ [1]

(ii) Work out the fraction of his earnings that he has left.

(ii) _____ [1]

(b) Gareth spends £100 of the £240 on rent.

Work out the fraction of his weekly earnings that Gareth spends on rent.
Give your answer in its simplest form.

(b) _____ [2]

9 Terry has 16 handkerchiefs of the following colours.

- 8 white
- 2 red
- 1 blue
- 5 pink

He chooses a handkerchief at random.

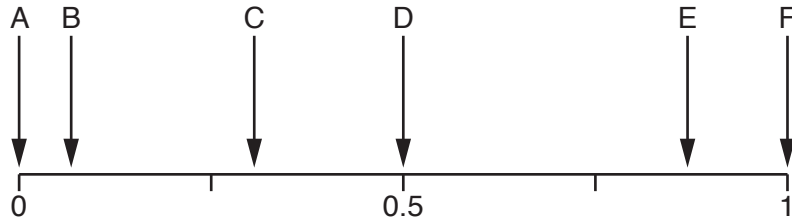

Which arrow shows the probability that the handkerchief is

(a) white,

(a) Arrow _____ [1]

(b) pink,

(b) Arrow _____ [1]

(c) not red,

(c) Arrow _____ [1]

(d) black?

(d) Arrow _____ [1]

10 (a) Simplify fully.

(i) $a + a + a + a$

(a)(i) _____ [1]

(ii) $\frac{14b}{7}$

(ii) _____ [1]

(iii) $6 \times c \times 4$

(iii) _____ [1]

(b) Solve these equations.

(i) $\frac{x}{2} = 8$

(b)(i) _____ [1]

(ii) $x + 3 = 7$

(ii) _____ [1]

(iii) $3x - 7 = 26$

(iii) _____ [2]

- 11 The table shows the train fares for a journey from Manchester to London. Passengers can travel either first class or standard class and during peak times or off-peak times.

	First class	Standard class
Peak time	£125	£75
Off-peak time	£39	£21

- (a) (i) The Brown family buy 3 tickets from Manchester to London for off-peak time.

Work out the difference in the **total** cost of the 3 tickets between the first class and standard class fares.

(a)(i) £ _____ [3]

- (ii) The train leaves Manchester at 11 10 and arrives in London at 13 53.

How long is the journey? Give your answer in hours and minutes.

(ii) _____ hours _____ minutes [2]

- (iii) The train makes a journey of 216 miles on the following day. The journey takes 3 hours.

Calculate the average speed of the train for this journey.

(iii) _____ mph [2]

- (b) A different train travels non-stop during **peak time** from Manchester to London. The total amount paid in fares for this journey was £14 075. 40 first class tickets were sold.

Work out the number of standard class tickets sold.

(b) _____ [3]

- 12 A pipe leaks 1 ml of water every 30 seconds.
 Geoff places an empty 9 litre bucket under the leaking pipe.

Work out the time, in hours, it will take to completely fill the 9 litre bucket.

_____ hours [4]

- 13 Hannah has a rectangular picture frame of length 30 cm and width 18 cm.
 The picture frame has a rectangular space of length 24 cm and width 12 cm in which to put a picture.

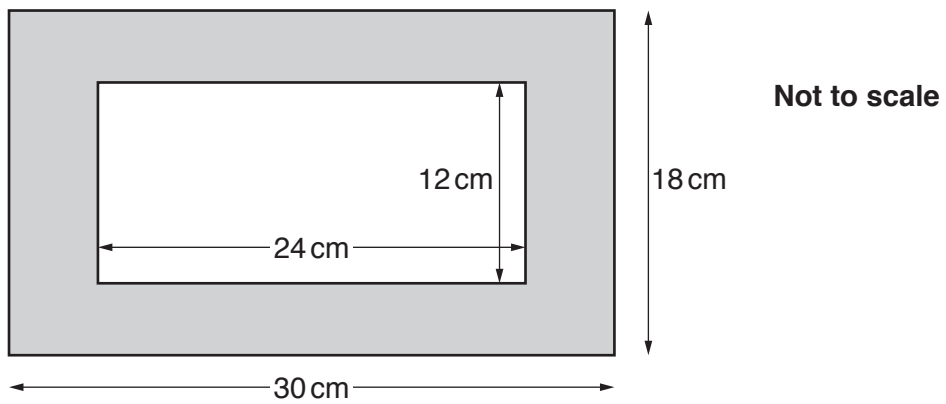

- (a) Find the perimeter of the outside of the picture frame.

(a) _____ cm [2]

- (b) Calculate the area of the picture frame, shown shaded.

(b) _____ cm² [3]

- (c) Hannah has a 'picture wall' on which to hang picture frames. All the picture frames are 30 cm by 18 cm.

This 'picture wall' is a rectangle 2 m wide and 130 cm high.

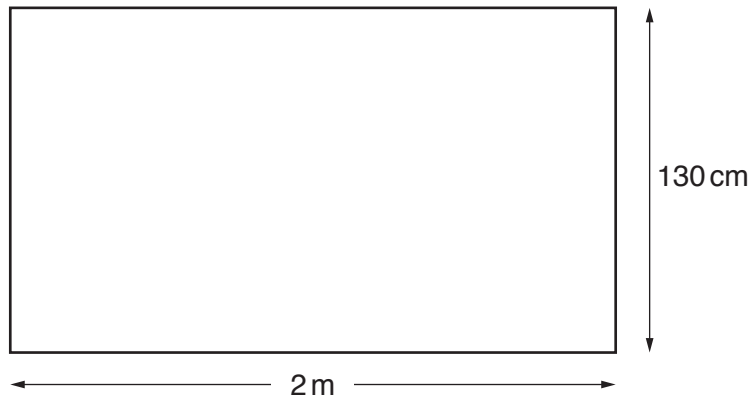

Hannah hangs all her picture frames in landscape style like this.

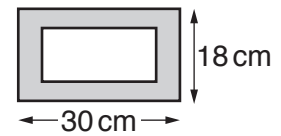

Work out the maximum number of these picture frames that Hannah can fit on her 'picture wall'.

(c) _____ [4]

14 A fair, four-sided spinner is numbered 1, 2, 3 and 4.

(a) The spinner is spun 140 times.

How many times would you expect it to land on 3?

(a) _____ [2]

(b) The spinner is spun twice and the scores added.

(i) Complete the table for the possible totals.

		First spin			
		1	2	3	4
Second spin	1			4	
	2				
	3				
	4				

[2]

(ii) What is the probability of spinning the spinner twice and getting a total of 4?

(b)(ii) _____ [2]

15 You are given the following information.

$$a + a + a = 24$$

$$a + b + b = 11$$

$$a + b + c = 7$$

Work out the value of a , the value of b and the value of c .

$$a = \underline{\hspace{10cm}}$$

$$b = \underline{\hspace{10cm}}$$

$$c = \underline{\hspace{10cm}} \quad [4]$$

16 The area of a circle is $25\pi \text{ cm}^2$.

Work out the circumference of this circle.
Give your answer in terms of π .

$$\underline{\hspace{10cm}} \text{ cm} \quad [3]$$

17 Here is a cuboid.

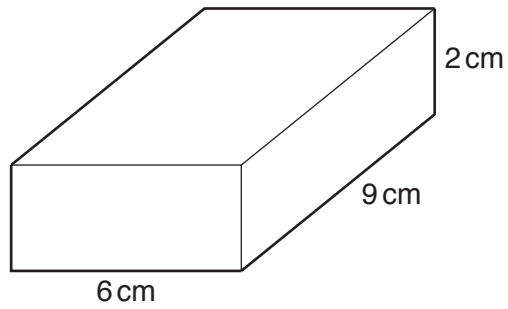

(a) Show that the volume of the cuboid is 108 cm^3 . [1]

(b) Another cuboid also has a volume of 108 cm^3 .
One edge of this cuboid is 4.5 cm .
Each of the other two edges is a whole number of centimetres.

Work out all possible pairs of lengths of the other two edges of the cuboid. [4]

18 (a) Complete the table for $y = x^2 + 2x$.

x	-4	-3	-2	-1	0	1	2
y	8	3	0		0		8

[2]

(b) On the grid, draw the graph of $y = x^2 + 2x$ for values of x from -4 to 2 .

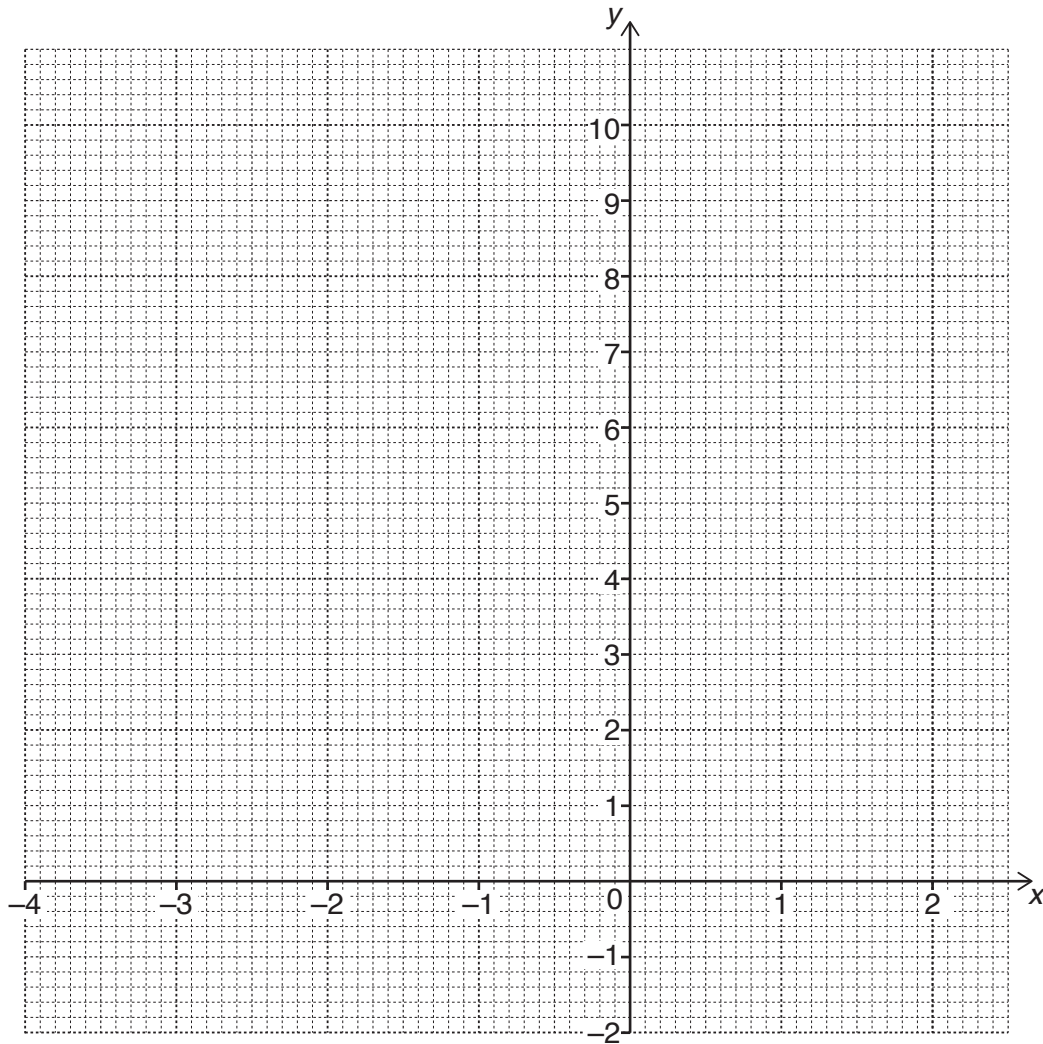

[2]

(c) Use your graph to solve the equation $x^2 + 2x = 1$.

(c) $x =$ _____ , $x =$ _____ [2]

- 19* Darius has a bag containing 3 white counters and 2 black counters.
Ellie has a bag containing 4 white counters and 1 black counter.

Darius puts one of his counters in Ellie's bag.
Darius' bag now has 4 counters and Ellie's bag now has 6 counters.

A counter is now chosen, at random, from each bag.
From whose bag is it now more likely that this counter will be white?
Give an answer for each of the two possible cases.

[6]

END OF QUESTION PAPER

19
BLANK PAGE

PLEASE DO NOT WRITE ON THIS PAGE

PLEASE DO NOT WRITE ON THIS PAGE



Copyright Information

OCR is committed to seeking permission to reproduce all third-party content that it uses in its assessment materials. OCR has attempted to identify and contact all copyright holders whose work is used in this paper. To avoid the issue of disclosure of answer-related information to candidates, all copyright acknowledgements are reproduced in the OCR Copyright Acknowledgements Booklet. This is produced for each series of examinations and is freely available to download from our public website (www.ocr.org.uk) after the live examination series.

If OCR has unwittingly failed to correctly acknowledge or clear any third-party content in this assessment material, OCR will be happy to correct its mistake at the earliest possible opportunity.

For queries or further information please contact the Copyright Team, First Floor, 9 Hills Road, Cambridge CB2 1GE.

OCR is part of the Cambridge Assessment Group; Cambridge Assessment is the brand name of University of Cambridge Local Examinations Syndicate (UCLES), which is itself a department of the University of Cambridge.