



Oxford Cambridge and RSA

Thursday 12 January 2017 – Afternoon

**LEVEL 1/2 CAMBRIDGE NATIONAL IN ENGINEERING
MANUFACTURE**

R109/01 Engineering materials, processes and production

Candidates answer on the Question Paper.

OCR supplied materials:

None

Other materials required:

None

Duration: 1 hour



Candidate forename		Candidate surname	
-----------------------	--	----------------------	--

Centre number						Candidate number				
---------------	--	--	--	--	--	------------------	--	--	--	--

INSTRUCTIONS TO CANDIDATES

- Use black ink. HB pencil may be used for graphs and diagrams only.
- Complete the boxes above with your name, centre number and candidate number.
- Answer **all** the questions.
- Write your answer to each question in the space provided. Additional paper may be used if necessary but you must clearly show your candidate number, centre number and question number(s).
- Do **not** write in the barcodes.

INFORMATION FOR CANDIDATES

- The total number of marks for this paper is **60**.
- The number of marks for each question is given in brackets [] at the end of each question or part question.
- Dimensions are in millimetres unless stated otherwise.
- Your quality of written communication will be assessed in questions marked with an asterisk (*).
- This document consists of **8** pages. Any blank pages are indicated.

Answer **all** the questions.

1 Non-ferrous metals are widely used in engineering manufacture.

(a) Complete the table below by placing a tick (✓) to show whether the non-ferrous metal given is a pure metal or an alloy.

The first one has been done for you.

Non-ferrous metal	Pure metal	Alloy
Aluminium	✓	
Brass		
Bronze		
Copper		
Lead		
Tin		
Titanium		

[6]

(b) Give **two** reasons why a non-ferrous metal might be used for making a product rather than a ferrous metal.

1

.....

.....

2

.....

.....

[4]

2 Malleability is one important property of engineering materials.

(a) (i) Explain what is meant by 'malleability'.

.....
.....
.....
..... [2]

(ii) Give **three** other properties of engineering materials.

1
2
3 [3]

(b) New materials, such as composites and advanced metal alloys, are constantly being developed.

(i) Give **two** examples of composite materials.



1
2 [2]

(ii) Explain the advantages of metal alloys compared with pure metals.

.....
.....
.....
.....
..... [3]

3 (a) The table below shows a number of threaded components.

Complete the table by giving the correct name for each of the components shown.

Component	Name
	
	
	
	
	

[5]

(b) Fig. 1 shows a special fixing component with internal and external threads.

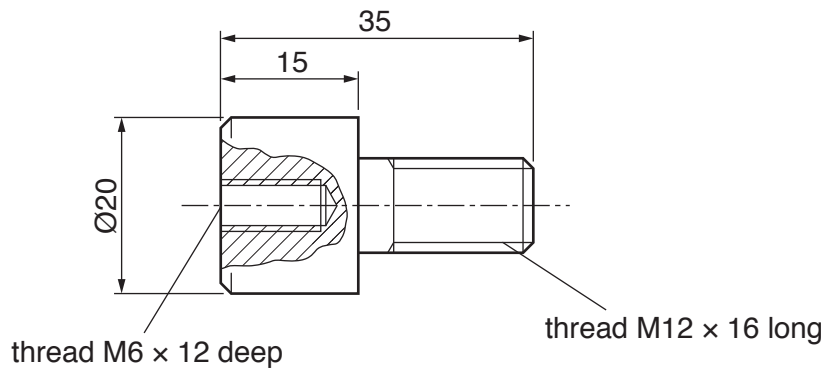

Fig. 1

(i) Name **three** tools needed to cut the M6 internal thread.

- 1
- 2
- 3

[3]

(ii) Give **two** methods that could be used to cut the M12 external thread.

- 1
- 2

[2]

4 Grinding is a machine process used for material removal.

(a) (i) Name **three** other machine processes used for material removal.

- 1
- 2
- 3 **[3]**

(ii) Give **three** safety precautions that should be taken when carrying out machine processes for material removal.

- 1
- 2
- 3 **[3]**

(b) Plastics moulding processes are widely used in engineering manufacture.

(i) Place a tick (✓) to show which process should be used for moulding thermosetting plastics.

Vacuum forming	Blow moulding	Compression moulding	Line bending

[1]

(ii) Explain why thermoplastics are more commonly used for making products than thermosetting plastics.

-
-
-
-
-
-
- **[3]**

5 Computer Numerical Control (CNC) is widely used in engineering manufacture.

(a) Describe what is meant by the term 'CNC machining centre'.

.....
.....
.....
..... [2]

(b) Describe the operation of a CNC press brake machine.

.....
.....
.....
..... [2]

6 (a) Give **three** cost issues that a manufacturer should consider before introducing modern technologies into production.

1

2

3 [3]

(b) Explain the impact of modern technologies on working conditions in manufacturing factories.

.....
.....
.....
.....
.....
..... [3]

(c) Describe **two** ways that digital communications might be used in global manufacturing.

1

2

..... [4]

END OF QUESTION PAPER



Copyright Information

OCR is committed to seeking permission to reproduce all third-party content that it uses in its assessment materials. OCR has attempted to identify and contact all copyright holders whose work is used in this paper. To avoid the issue of disclosure of answer-related information to candidates, all copyright acknowledgements are reproduced in the OCR Copyright Acknowledgements Booklet. This is produced for each series of examinations and is freely available to download from our public website (www.ocr.org.uk) after the live examination series.

If OCR has unwittingly failed to correctly acknowledge or clear any third-party content in this assessment material, OCR will be happy to correct its mistake at the earliest possible opportunity.

For queries or further information please contact the Copyright Team, First Floor, 9 Hills Road, Cambridge CB2 1GE.

OCR is part of the Cambridge Assessment Group; Cambridge Assessment is the brand name of University of Cambridge Local Examinations Syndicate (UCLES), which is itself a department of the University of Cambridge.