MEI STRUCTURED MATHEMATICS

A Credit Accumulation Scheme for Advanced Mathematics

OCR ADVANCED SUBSIDIARY GCE IN MATHEMATICS (MEI)	(3895)
OCR ADVANCED SUBSIDIARY GCE IN FURTHER MATHEMATICS (MEI)	(3896/3897)
OCR ADVANCED SUBSIDIARY GCE IN PURE MATHEMATICS (MEI)	(3898)
OCR ADVANCED GCE IN MATHEMATICS (MEI)	(7895)
OCR ADVANCED GCE IN FURTHER MATHEMATICS (MEI)	(7896/7897)
OCR ADVANCED GCE IN PURE MATHEMATICS (MEI)	(7898)

QAN (3895) 100/3417/1 QAN (3896/3897) 100/6016/9 QAN (3898) 100/6017/0 QAN (7895) 100/3418/3 QAN (7896/7897) 100/6018/2
QAN (7898) 100/6019/4

Key Features

- Unrivalled levels of support and advice.
- Web-based resources covering the units.
- Clear and appropriate progression routes from GCSE for all students.
- Flexibility in provision of Further Mathematics.
- User friendly and accessible.

This specification was devised by Mathematics in Education and Industry (MEI) and is administered by OCR.

Support and Advice

The specification is accompanied by a complete support package provided by MEI and OCR. The two organisations work closely together with MEI taking responsibility for the curriculum and teaching aspects of the course, and OCR the assessment.

- Advice is always available at the end of the telephone or by e-mail.
- One-day INSET courses provided by both MEI and OCR.
- The MEI annual three-day conference.
- MEI branch meetings.
- Regular newsletters from MEI.
- Specimen and past examination papers, mark schemes and examiners' reports.
- Coursework resource materials and exemplar marked tasks.

Web-based Support

The units in this specification are supported by a very large purpose-built website designed to help students and teachers.

Routes of Progression

This specification is designed to provide routes of progression through mathematics between GCSE and Higher Education and/or employment. It has the flexibility to meet the diverse needs of the wide variety of students needing mathematics at this level.

Further Mathematics

A feature of this specification is the flexibility that it allows teachers in delivering Further Mathematics. It is possible to teach this concurrently with AS and Advanced GCE Mathematics, starting both at the same time, or to teach the two courses sequentially, or some combination of the two.

User friendliness

This specification has been designed by teachers for students. Thus the accompanying text books, one for each unit, are accessible to students, easy to read and work from. The *Students' Handbook* provides a particularly helpful source of information.

AS assessment June 2014
A2 assessment June 2014
AS certification June 2014
GCE certification June 2014

CONTENTS

Section A: SPECIFICATION SUMMARY	5
Section B: USER SUMMARY	7
Using this specification	7
Summary of Changes from the Previous MEI Specification	8
Section C: General Information	9
1 Introduction	9
1.1 Rationale	9
1.2 Certification title	12
1.3 Language	13
1.4 Exclusions	13
1.5 Key Skills	14
1.6 Code of Practice Requirements	14
1.7 Spiritual, Moral, Ethical, Social and Cultural Issues	14
1.8 Environmental Education, European Dimension and Health and Safety Issues	15
1.9 Avoidance of Bias	15
1.10 Calculators and computers	15
2 Specification Aims	16
2.1 Aims of MEI	16
2.2 Aims of this specification	16
3 Assessment Objectives	17
3.1 Application to AS and A2	17
3.2 Specification Grid	18
4 Scheme of Assessment	19
4.1 Units of Assessment	19
4.2 structure	20
4.3 Rules of Combination	22
4.4 Final Certification	25
4.5 Availability	27
4.6 Re-sits	27
4.7 Question Papers	28
4.8 Coursework	29
4.9 Special Arrangements	31
4.10 Differentiation	32
4.11 Grade Descriptions	32
5 Subject Content	34
5.1 Assumed Knowledge	34
5.2 Modelling	35
5.3 Competence Statements	36

6	Unit Specifications	37
6.1	Introduction to Advanced Mathematics, C1 (4751) AS	37
6.2	Concepts for Advanced Mathematics, C2 (4752) AS	47
6.3	Methods for Advanced Mathematics, C3 (4753) A2	55
6.4	Applications of Advanced Mathematics, C4 (4754) A2	67
6.5	Further Concepts for Advanced Mathematics, FP1 (4755) AS	73
6.6	Further Methods for Advanced Mathematics, FP2 (4756) A2	81
6.7	Further Applications of Advanced Mathematics, FP3 (4757) A2	93
6.8	Differential Equations, DE (4758) A2	105
6.9	Mechanics 1, M1 (4761) AS	115
6.10	Mechanics 2, M2 (4762) A2	123
6.11	Mechanics 3, M3 (4763) A2	129
6.12	Mechanics 4, M4 (4764) A2	137
6.13	Statistics 1, S1 (4766) AS	143
6.14	Statistics 2, S2 (4767) A2	153
6.15	Statistics 3, S3 (4768) A2	159
6.16	Statistics 4, S4 (4769) A2	165
6.17	Decision Mathematics 1, D1 (4771) AS	175
6.18	Decision Mathematics 2, D2 (4772) A2	181
6.19	Decision Mathematics Computation, DC (4773) A2	187
6.20	Numerical Methods, NM (4776) AS	193
6.21	Numerical Computation, NC (4777) A2	201
6.22	Further Pure Mathematics with Technology, FPT (4798) A2	207
7	Further Information and Training for Teachers	214
	Appendix A: Mathematical Formulae	215
	Appendix B: Mathematical Notation	217

Vertical black lines indicate a significant change to the previous printed version.

SECTION A: SPECIFICATION SUMMARY

The units in MEI Structured Mathematics form a step-by-step route of progression through the subject, from GCSE into the first year of university. For those who are insecure about their foundation, access to the scheme is provided by the Free Standing Mathematics Qualification, *Foundations of Advanced Mathematics*.

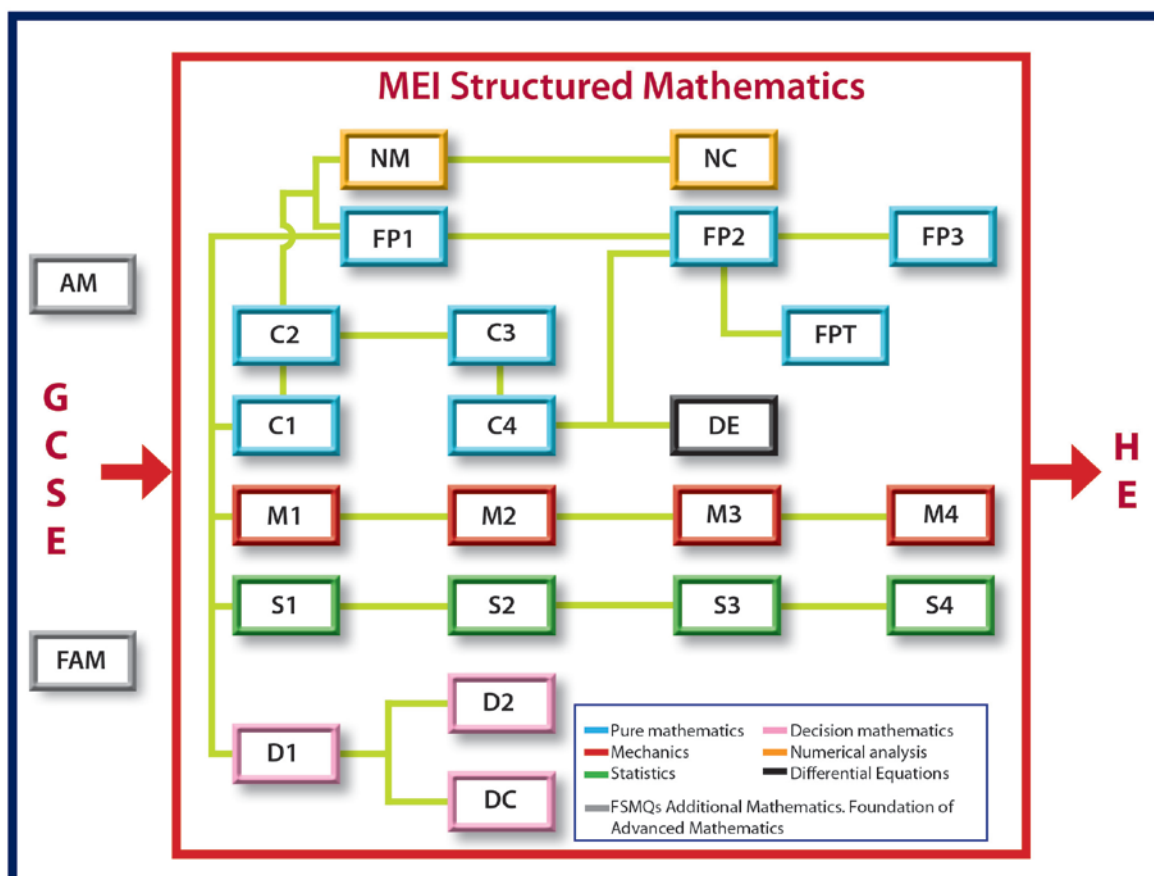

The subject is developed consistently and logically through the 22 AS and A2 units, following strands of Pure Mathematics, Mechanics, Statistics, Decision Mathematics and Numerical Analysis. Each unit is designed both as a worthwhile and coherent course of study in its own right, taking about 45 hours of teaching time, and as a stepping stone to further work.

Suitable combinations of three and six modules give rise to AS and Advanced GCE qualifications in Mathematics, Further Mathematics and Pure Mathematics. Candidates usually take their units at different stages through their course, accumulating credit as they do so.

The normal method of assessment is by unit examinations, held in June each year, in most cases lasting 1½ hours. Three units also have coursework requirements. Candidates are allowed to re-sit units, with the best mark counting.

The Advanced Subsidiary GCE is assessed at a standard appropriate for candidates who have completed the first year of study of a two-year Advanced GCE course, i.e. between GCSE and Advanced GCE. It forms the first half of the Advanced GCE course in terms of teaching time and content. When combined with the second half of the Advanced GCE course, known as 'A2', the advanced Subsidiary forms 50% of the assessment of the total Advanced GCE. However the Advanced Subsidiary can be taken as a stand-alone qualification. A2 is weighted at 50% of the total assessment of the Advanced GCE.

SECTION B: USER SUMMARY

USING THIS SPECIFICATION

This specification provides a route of progression through mathematics between GCSE and Higher Education and/or employment.

- Students start with AS Mathematics. This consists of the two AS units in Pure Mathematics, *C1* and *C2*, together with one applied unit, either *M1*, *S1* or *D1*.
- Many students take one year over AS Mathematics but this is not a requirement; they can take a longer or a shorter time, as appropriate to their circumstances.
- Examinations are available in June only.
- Unit results are notified in the form of a grade and a Uniform Mark. The total of a candidate's Uniform Marks on relevant modules determines the grade awarded at AS GCE (or Advanced GCE).
- A unit may be re-sat any number of times with the best result standing.
- To obtain an AS award a 'certification entry' must be made to OCR. There is no requirement for candidates going on to Advanced GCE to make such an entry.
- To complete Advanced GCE Mathematics, candidates take three more units, *C3*, *C4* and another applied unit.
- The applied unit may be in the same strand as that taken for AS in which case it will be an A2 unit (e.g. *S2* following on from *S1*). Alternatively it may be in a different strand in which case it will be an AS unit (e.g. *M1* following on from *S1*).
- Many candidates will take these three units in the second year of their course but there is no requirement for this to be the case.
- An Advanced GCE award will only be made to those who apply for it.
- Candidates may also take Further Mathematics at AS and Advanced GCE. There is considerable flexibility in the way that this can be done.
- AS Further Mathematics consists of *FP1* and two other units which may be AS or A2.
- The three units for AS Further Mathematics may be taken in the first year. The compulsory unit *FP1* has been designed to be accessible for students who have completed Higher Tier GCSE and are studying *C1* and *C2* concurrently. The AS units, *M1*, *S1*, *D1* and *NM* are also suitable for those taking AS Further Mathematics in the first year.
- Many of those who take AS Further Mathematics in the first year then take another three units in their second year to obtain Advanced GCE Further Mathematics. Such candidates take 12 units, six for Mathematics and six for Further Mathematics.
- Other AS Further Mathematics students spread their study over two years rather than completing it in the first year.
- Another pattern of entry is for candidates to complete Advanced GCE Mathematics in their first year and then to go onto Further Mathematics in their second year.
- Those who take Advanced GCE Mathematics and AS Further Mathematics must do at least 9 units.
- Those who take Advanced GCE Mathematics and Advanced GCE Further Mathematics must do at least 12 units. The Further Mathematics must include both *FP1* and *FP2*.

- The rules of aggregation mean that it is to candidates' advantage to certificate Advanced GCE Mathematics and AS or Advanced GCE Further Mathematics at the same time. This can be achieved, if necessary, by recertificating for any previously entered qualification in any series when an entry for a qualification is made.
- Candidates who take 15 or 18 units are eligible for additional awards in Further Mathematics.

SUMMARY OF CHANGES FROM THE PREVIOUS MEI SPECIFICATION

The revisions to the subject criteria have resulted in considerable changes to the assessment arrangements compared to those in the previous specification (those for first teaching in September 2000). These in turn have affected the provision of units in MEI Structured Mathematics and their content:

- the core material is now covered in four units, two at AS and two at A2. The two AS units are compulsory for Advanced Subsidiary Mathematics and all four core units are compulsory for Advanced GCE Mathematics;
- consequently the first four units in the Pure Mathematics strand, *C1* to *C4* are all new;
- only two applied units now contribute to Advanced GCE Mathematics;
- the reduction in the amount of Applied Mathematics in Advanced GCE Mathematics means that it is no longer feasible to provide as many applied units for Further Mathematics, and so there are fewer Mechanics and Statistics units. However the provision in Decision Mathematics remains unaltered;
- *Mechanics 4* and *Statistics 4* are new units, drawing material from a number of units in the previous specification;
- in addition there are some changes to *Statistics 1*, *2* and *3*; these reflect their new status within the Advanced GCE, particularly the fact that *Statistics 3* is no longer the natural ending point for those Advanced GCE students whose Applied Mathematics is entirely statistics;
- Advanced Subsidiary Further Mathematics may now be obtained on **three** AS units. One of these is a new Pure Mathematics unit *Further Concepts for Advanced Mathematics, FPI*;
- the content of *Further Concepts for Advanced Mathematics, FPI*, depends only on the AS subject criteria and so is inevitably different from that of the unit which it replaces. This change has had knock-on effects to the content of the two remaining units in Pure Mathematics;
- the number of subject titles available has been reduced in line with the new subject criteria.

In addition, there are some other changes that are not a direct consequence of the new subject criteria. In particular, those responsible for this specification were aware that, following the introduction of Curriculum 2000, mathematics was making much greater demands on students' time than other subjects and so there is a reduction in the amount of coursework required.

SECTION C: GENERAL INFORMATION

1 Introduction

1.1 RATIONALE

1.1.1 This Specification

This booklet contains the specification for MEI Structured Mathematics for teaching from September 2013. It covers Advanced Subsidiary GCE (AS) and Advanced GCE (A Level) qualifications in Mathematics and Further Mathematics and also in Pure Mathematics.

This specification was developed by Mathematics in Education and Industry (MEI) and is assessed by OCR. Support for those delivering the specification comes from both bodies and this is one of its particular strengths.

This specification is designed to help more students to fulfil their potential by taking and enjoying mathematics courses that are relevant to their needs post-16. This involves four key elements: breadth, depth, being up-to-date and providing students with the ability to use their mathematics.

- Most students at this level are taking mathematics as a support subject. Their needs are almost as diverse as their main fields of study, and consequently this specification includes the breadth of several distinct strands of mathematics: Pure Mathematics, Mechanics, Statistics, Decision Mathematics and Numerical Analysis.
- There are, however, those students who will go on to read mathematics at university and perhaps then become professional mathematicians. These students need the challenge of taking the subject to some depth and this is provided by the considerable wealth of Further Mathematics units in this specification, culminating in *FP3*, *M4* and *S4*.
- Mathematics has been transformed at this level by the impact of modern technology: the calculator, the spreadsheet and dedicated software. There are many places where this specification either requires or strongly encourages the use of such technology. The units *DC*, *NC* and *FPT* have computer based examinations; an option in *FP3* is based on graphical calculators, and the coursework in *C3* and *NM* is based on the use of suitable devices.
- Many students complete mathematics courses quite well able to do routine examination questions but unable to relate what they have learnt to the world around them. This specification is designed to provide students with the necessary interpretive and modelling skills to be able to use their mathematics. Modelling and interpretation are stressed in the papers and some of the coursework and there is a comprehension paper as part of the assessment of *C4*.

MEI is a curriculum development body and in devising this specification the long term needs of students have been its paramount concern.

This specification meets the requirements of the Common Criteria (QCA, 1999), the GCE Advanced Subsidiary and Advanced Level Qualification-Specific Criteria (QCA, 1999) and the Subject Criteria for Mathematics (QCA, 2002).

1.1.2 MEI and OCR

MEI is a long established, independent curriculum development body, with a membership consisting almost entirely of working teachers. MEI provide advice and INSET relating to all the curriculum and teaching aspects of the course. It also provides teaching materials, and the accompanying series of textbooks is the product of a partnership between MEI and a major publishing house. A particular feature of this specification is the very substantial website (see Section 7), covering all the various units. Students can access this at school or college, or when working at home. Not only does this help them with their immediate mathematics course; it also develops the skills they will need for independent learning throughout their lives.

OCR's involvement is primarily centred on the assessment, awarding and issuing of results. However, members of the Qualification Team are available to give advice, receive feedback and give general support.

OCR also provides INSET and materials such as Examiners' Reports, mark schemes and past papers.

It is thus a feature of this specification that an exceptional level of help is always available to teachers and students, at the end of the telephone or on-line.

1.1.3 Background

The period leading up to the start of this specification has been a difficult one for post-16 mathematics with a substantial drop in the numbers taking the subject. This specification has been designed to redress that situation by ensuring that the various units can indeed be taught and learnt within the time allocated.

Considerable thought has gone into its design, and from a large number of people, many of them classroom teachers or lecturers. Those responsible are confident that the specification makes full use of the new opportunities opened up by the changes to the subject criteria: mathematics will be accessible to many more students but will also provide sufficient challenge for the most able.

MEI Structured Mathematics was first introduced in 1990 and was subsequently refined in 1994 and 2000 to take account of new subject cores and advice from teachers and lecturers. The philosophy underlying the 1990 specification was described in its introduction, which is reproduced verbatim later in this section.

This specification represents a new interpretation of the same philosophy. It takes account not only of the requirements of the 2002 subject criteria but also of the quite different environment in which post-16 mathematics is now embedded.

The major changes from the previous MEI specification (that for first teaching in September 2000) are outlined for the convenience of users on page 8 of this specification. However, it is more appropriate to see this as a specification in its own right, which, while building on past experience, is designed for present-day students working in present-day conditions.

1.1.4 New Opportunities

The new subject criteria, published by QCA in December 2002, are intended to make mathematics more accessible for students and easier for schools and colleges to deliver within existing time constraints. This specification is designed to take full advantage of the opportunities this opens up.

The content of the subject core is little changed but it is now spread over four units, two at AS and two at A2, instead of the previous three. This means that the content of each individual Pure Mathematics unit is reduced so that more time can be given to teaching the topics within it.

A particular feature of this specification is the first Pure Mathematics unit, *C1*. It is designed to give students a firm foundation in the basic skills that they will need for all their other units, thereby making advanced study of mathematics accessible to many more people.

Another major new opportunity occurs with Further Mathematics. It is now, for the first time, possible to obtain AS Further Mathematics on three AS units. In this specification, the first Pure Mathematics unit, *FPI*, is a genuine AS unit and students who have been successful at Higher Tier GCSE should be able to start studying it at the same time as *C1* and *C2*. It will no longer be necessary for potential Further Mathematics students to mark time while they learn enough of the single Mathematics to allow them to get started.

It is however still possible for schools and colleges to deliver Further Mathematics in other ways: for example by doing three extra units over the two years for the AS qualification. That point illustrates another feature of this specification, its flexibility. It is designed to meet the needs of a wide range of students, from those who find AS Level a real challenge to others who are blessed with extraordinary talent in mathematics. The flexibility also covers the needs of schools and colleges with widely differing numbers of post-16 mathematics students.

1.1.5 A Route of Progression

MEI Structured Mathematics is designed not just to be a specification for AS or Advanced GCE Mathematics but to provide a route of progression through the subject starting from GCSE and going into what is first year work in some university courses. The specification is also, by design, entirely suitable for those who are already in employment, or are intending to progress directly into it.

1.1.6 Underlying Philosophy: Introduction to the 1990 Syllabus

This section contains the introduction to the first MEI Structured Mathematics specification and is included as a statement of underlying philosophy. These were the first modular A Levels in any subject and their development was accompanied by serious consideration of how the needs of industry and adult life could best be addressed through a mathematics specification.

‘Our decision to develop this structure, based on 45-hour Components, for the study of Mathematics beyond GCSE stems from our conviction, as practising teachers, that it will better meet the needs of our students. We believe its introduction will result in more people taking the subject at both A and AS, and that the use of a greater variety of assessment techniques will allow content to be taught and learnt more appropriately with due emphasis given to the processes involved.

Mathematics is required by a wide range of students, from those intending to read the subject at university to those needing particular techniques to support other subjects or their chosen careers. Many syllabuses are compromises between these needs, but the necessity to accommodate the most able students results in the content being set at a level which is inaccessible to many, perhaps the majority of, sixth formers. The choice allowed within this scheme means that in planning courses centres will be able to select those components that are relevant to their students' needs, confident that the work will be at an appropriate level of difficulty.

While there are some areas of Mathematics which we feel to be quite adequately assessed by formal examination, there are others which will benefit from the use of alternative assessment methods, making possible, for example, the use of computers in Numerical Analysis and of substantial sets of data in Statistics. Other topics, like Modelling and Problem Solving, have until now been largely untested because by their nature the time they take is longer than can be allowed in an examination. A guiding principle of this scheme is that each Component is assessed in a manner appropriate to its content.

We are concerned that students should learn an approach to Mathematics that will equip them to use it in the adult world and to be able to communicate what they are doing to those around them. We believe that this cannot be achieved solely by careful selection of syllabus content and have framed our Coursework requirements to develop skills and attitudes which we believe to be important. Students will be encouraged to undertake certain Coursework tasks in teams and to give presentations of their work. To further a cross-curricular view of Mathematics we have made provision for suitable Coursework from other subjects to be admissible.

We believe that this scheme will do much to improve both the quantity and the quality of Mathematics being learnt in our schools and colleges.'

1.2 CERTIFICATION TITLE

This specification will be shown on a certificate as one or more of the following:

- OCR Advanced Subsidiary GCE in Mathematics (MEI)
- OCR Advanced Subsidiary GCE in Further Mathematics (MEI)
- OCR Advanced Subsidiary GCE in Pure Mathematics (MEI)

- OCR Advanced GCE in Mathematics (MEI)
- OCR Advanced GCE in Further Mathematics (MEI)
- OCR Advanced GCE in Pure Mathematics (MEI)

Candidates who complete 15 or 18 units respectively will have achieved at least the equivalent of the standard of Advanced Subsidiary GCE Further Mathematics and Advanced GCE Further Mathematics in their additional units. The achievements of such candidates will be recognised by additional awards in Further Mathematics (Additional) with the code numbers 3897 (AS) and 7897 (Advanced GCE).

1.3 LANGUAGE

This specification, and all associated assessment materials, are available only in English. The language used in all question papers will be plain, clear, free from bias and appropriate to the qualification.

1.4 EXCLUSIONS

1.4.1 Exclusions within this Specification

Qualifications in Further Mathematics are **not** free-standing. Thus:

- candidates for Advanced Subsidiary GCE in Further Mathematics are required either to have obtained, or to be currently obtaining, either an Advanced Subsidiary GCE in Mathematics or an Advanced GCE in Mathematics;
- candidates for Advanced GCE in Further Mathematics are required either to have obtained, or to be currently obtaining, an Advanced GCE in Mathematics.

Advanced Subsidiary GCE in Pure Mathematics may **not** be taken with any other Advanced Subsidiary GCE qualification within this specification.

Advanced GCE in Pure Mathematics may **not** be taken with any other Advanced GCE qualification within this specification.

1.4.2 Exclusions Relating to other Specifications

No Advanced Subsidiary GCE qualification within this specification may be taken at the same time as any other Advanced Subsidiary GCE having the same title nor with OCR Free Standing Mathematics Qualification (Advanced): Additional Mathematics.

No Advanced GCE qualification within this specification may be taken with any other Advanced GCE having the same title.

Candidates may not obtain certification (under any title) from this specification, based on units from other mathematics specifications, without prior permission from OCR.

Candidates may not enter a unit from this specification and a unit with the same title from other mathematics specifications.

Every specification is assigned to a national classification code indicating the subject area to which it belongs. Centres should be aware that candidates who enter for more than one GCE qualification with the same classification code will have only one grade (the highest) counted for the purpose of School and College Performance Tables.

The national classification codes for the subjects covered by this specification are as follows:

Mathematics	2210
Pure Mathematics	2230
Further Mathematics	2330

1.5 KEY SKILLS

In accordance with the aims of MEI, this scheme has been designed to meet the request of industry (e.g. the CBI) that students be provided with opportunities to use and develop Key Skills.

The table below indicates which modules are particularly likely to provide opportunities for the various Key Skills at Level 3.

Module		Communication	Application of Number	Information Technology	Working with Others	Improving Own Learning and Performance	Problem Solving
C3	4753	✓	✓	✓		✓	
C4	4754	✓				✓	
DE	4758	✓	✓	✓	✓	✓	✓
DC	4773			✓		✓	
NM	4776	✓	✓	✓	✓	✓	✓
NC	4777			✓		✓	
FPT	4798			✓		✓	✓

1.6 CODE OF PRACTICE REQUIREMENTS

All qualifications covered by this specification will comply in all aspects with the GCE Code of Practice for courses starting in September 2004.

1.7 SPIRITUAL, MORAL, ETHICAL, SOCIAL AND CULTURAL ISSUES

Students are required to examine arguments critically and so to distinguish between truth and falsehood. They are also expected to interpret the results of modelling exercises and there are times when this inevitably raises moral and cultural issues. Such issues will not be assessed in the examination questions; nor do they feature, per se, in the assessment criteria for any coursework tasks.

1.8 ENVIRONMENTAL EDUCATION, EUROPEAN DIMENSION AND HEALTH AND SAFETY ISSUES

While the work developed in teaching this specification may use examples, particularly involving modelling and statistics, that raise environmental issues, these issues do not in themselves form part of the specification.

The work developed in teaching this specification may at times involve examples that raise health and safety issues. These issues do not in themselves form part of this specification.

OCR has taken account of the 1988 Resolution of the Council of the European Community and the Report *Environmental Responsibility: An Agenda for Further and Higher Education*, 1993 in preparing this specification and associated specimen assessment materials.

Teachers should be aware that students may be exposed to risks when doing coursework. They should apply usual laboratory precautions when experimental work is involved. Students should not be expected to collect data on their own when outside their Centre.

Teachers should be aware of the dangers of repetitive strain injury for any student who spends a long time working on a computer.

1.9 AVOIDANCE OF BIAS

MEI and OCR have taken great care in the preparation of this specification and assessment materials to avoid bias of any kind.

1.10 CALCULATORS AND COMPUTERS

Students are expected to make appropriate use of graphical calculators and computers. The JCQ document *Instructions for conducting examinations*, published annually, contains the regulations regarding the use of calculators in examinations.

2 Specification Aims

2.1 AIMS OF MEI

‘To promote the links between education and industry at Secondary School level, and to produce relevant examination and teaching specifications and support material.’

2.2 AIMS OF THIS SPECIFICATION

This course should encourage students to:

- develop their understanding of mathematics and mathematical processes in a way that promotes confidence and fosters enjoyment;
- develop abilities to reason logically and recognise incorrect reasoning, to generalise and to construct mathematical proofs;
- extend their range of mathematical skills and techniques and use them in more difficult, unstructured problems;
- develop an understanding of coherence and progression in mathematics and of how different areas of mathematics can be connected;
- recognise how a situation may be represented mathematically and understand the relationship between ‘real world’ problems and standard and other mathematical models and how these can be refined and improved;
- use mathematics as an effective means of communication;
- read and comprehend mathematical arguments and articles concerning applications of mathematics;
- acquire the skills needed to use technology such as calculators and computers effectively, recognise when such use may be inappropriate and be aware of limitations;
- develop an awareness of the relevance of mathematics to other fields of study, to the world of work and to society in general;
- take increasing responsibility for their own learning and the evaluation of their own mathematical development.

3 Assessment Objectives

3.1 APPLICATION TO AS AND A2

This specification requires students to demonstrate the following assessment objectives in the context of the knowledge, understanding and skills prescribed. The assessment objectives for Advanced Subsidiary GCE and for Advanced GCE are the same.

Students should be able to demonstrate that they can:

AO1

- recall, select and use their knowledge of mathematical facts, concepts and techniques in a variety of contexts.

AO2

- construct rigorous mathematical arguments and proofs through use of precise statements, logical deduction and inference and by the manipulation of mathematical expressions, including the construction of extended arguments for handling substantial problems presented in unstructured form.

AO3

- recall, select and use their knowledge of standard mathematical models to represent situations in the real world;
- recognise and understand given representations involving standard models;
- present and interpret results from such models in terms of the original situation, including discussion of assumptions made and refinement of such models.

AO4

- comprehend translations of common realistic contexts into mathematics;
- use the results of calculations to make predictions, or comment on the context;
- where appropriate, read critically and comprehend longer mathematical arguments or examples of applications.

AO5

- use contemporary calculator technology and other permitted resources (such as formulae booklets or statistical tables) accurately and efficiently;
- understand when not to use such technology, and its limitations;
- give answers to appropriate accuracy.

3.2 SPECIFICATION GRID

The table below gives the permitted allocation of marks to assessment objectives for the various units. The figures given are percentages. These allocations ensure that any allowable combination of units for AS Mathematics or Advanced GCE Mathematics satisfies the weightings given in *Subject Criteria for Mathematics*.

Entry Code	Unit Code	Unit Name	Level	Weighting of Assessment Objective (%)				
				AO1	AO2	AO3	AO4	AO5
4751	C1	Introduction to Advanced Mathematics	AS	40-50	40-50	0-10	0-10	0-5
4752	C2	Concepts for Advanced Mathematics	AS	30-40	30-40	5-15	5-15	10-20
4753	C3	Methods for Advanced Mathematics	A2	40-45	40-45	0-10	0-10	10-20
4754	C4	Applications of Advanced Mathematics	A2	30-35	30-35	10-20	15-25	5-15
4755	FP1	Further Concepts for Advanced Mathematics	AS	35-45	35-45	0-10	0-10	0-10
4756	FP2	Further Methods for Advanced Mathematics	A2	35-45	35-45	0-10	0-10	0-10
4757	FP3	Further Applications of Advanced Mathematics	A2	35-45	35-45	0-10	0-10	0-10
4758	DE	Differential Equations	A2	20-30	20-30	25-35	10-20	5-15
4761	M1	Mechanics 1	AS	20-30	20-30	25-35	10-20	5-15
4762	M2	Mechanics 2	A2	20-30	20-30	25-35	10-20	5-15
4763	M3	Mechanics 3	A2	20-30	20-30	25-35	10-20	5-15
4764	M4	Mechanics 4	A2	20-30	20-30	25-35	10-20	5-15
4766	S1	Statistics 1	AS	20-30	20-30	25-35	10-20	5-15
4767	S2	Statistics 2	A2	20-30	20-30	25-35	10-20	5-15
4768	S3	Statistics 3	A2	20-30	20-30	25-35	10-20	5-15
4769	S4	Statistics 4	A2	20-30	20-30	25-35	10-20	5-15
4771	D1	Decision Mathematics 1	AS	20-30	20-30	25-35	10-20	5-15
4772	D2	Decision Mathematics 2	A2	20-30	20-30	25-35	10-20	5-15
4773	DC	Decision Mathematics Computation	A2	20-30	20-30	25-35	5-15	10-30
4776	NM	Numerical Methods	AS	30-40	30-40	0-10	0-10	20-30
4777	NC	Numerical Computation	A2	25-35	25-35	0-10	10-20	20-30
4798	FPT	Further Pure Mathematics with Technology	A2	30-40	30-40	0	0	25-40

4 Scheme of Assessment

4.1 UNITS OF ASSESSMENT

4.1.1 Summary Table

Entry Code	Unit Code	Level	Unit Name	Examination Questions* (approximate mark allocation)	Time (hours)
4751	C1	AS	Introduction to Advanced Mathematics	A: $8-10 \times \leq 5 = 36$; B: $3 \times 12 = 36$	1½
4752	C2	AS	Concepts for Advanced Mathematics	A: $8-10 \times \leq 5 = 36$; B: $3 \times 12 = 36$	1½
4753	C3	A2	Methods for Advanced Mathematics	A: $5-7 \times \leq 8 = 36$; B: $2 \times 18 = 36$ Coursework: 18	1½
4754	C4	A2	Applications of Advanced Mathematics Paper A	A: $5-7 \times \leq 8 = 36$; B: $2 \times 18 = 36$	1½
			Applications of Advanced Mathematics Paper B	Comprehension: 18	1
4755	FP1	AS	Further Concepts for Advanced Mathematics	A: $5-7 \times \leq 8 = 36$; B: $3 \times 12 = 36$	1½
4756	FP2	A2	Further Methods for Advanced Mathematics	A: $3 \times 18 = 54$; B: $1 \times 18 = 18$	1½
4757	FP3	A2	Further Applications of Advanced Mathematics	$3 \text{ (from 5)} \times 24 = 72$	1½
4758	DE	A2	Differential Equations	$3 \text{ (from 4)} \times 24 = 72$; Coursework: 18	1½
4761	M1	AS	Mechanics 1	A: $5-7 \times \leq 8 = 36$; B: $2 \times 18 = 36$	1½
4762	M2	A2	Mechanics 2	$4 \times 18 = 72$	1½
4763	M3	A2	Mechanics 3	$4 \times 18 = 72$	1½
4764	M4	A2	Mechanics 4	A: $2 \times 12 = 24$; B: $2 \times 24 = 48$	1½
4766	S1	AS	Statistics 1	A: $5-7 \times \leq 8 = 36$; B: $2 \times 18 = 36$	1½
4767	S2	A2	Statistics 2	$4 \times 18 = 72$	1½
4768	S3	A2	Statistics 3	$4 \times 18 = 72$	1½
4769	S4	A2	Statistics 4	$3 \text{ (from 4)} \times 24 = 72$	1½
4771	D1	AS	Decision Mathematics 1	A: $3 \times 8 = 24$; B: $3 \times 16 = 48$	1½
4772	D2	A2	Decision Mathematics 2	A: $2 \times 16 = 32$; B: $2 \times 20 = 40$	1½
4773	DC	A2	Decision Mathematics Computation	$4 \times 18 = 72$	2½
4776	NM	AS	Numerical Methods	A: $5-7 \times \leq 8 = 36$; B: $2 \times 18 = 36$ Coursework: 18	1½
4777	NC	A2	Numerical Computation	$3 \text{ (from 4)} \times 24 = 72$	2½
4798	FPT	A2	Further Pure Mathematics with Technology	$3 \times 24 = 72$	2

* number of questions x number of marks for each = total mark

For Units 4753, 4758 and 4776, Centres have the option of submitting new coursework (entry code Option A) or carrying forward a coursework mark from a previous session (Option B).

4.1.2 Weighting

For all certifications, the contribution of each unit is the same. Thus each unit carries $33\frac{1}{3}\%$ of the total marks for an Advanced Subsidiary certification and $16\frac{2}{3}\%$ of the total marks for an Advanced GCE certification.

4.2 STRUCTURE

4.2.1 Recommended Order

The assumed knowledge required to start any unit is stated on the title page of its specification. In general, students are recommended to take the units in any strand in numerical order.

Students will also find it helpful to refer to the diagram on the cover of this specification and also on page 5. The lines connecting the various units indicate the recommended order and the positions (left to right) of the units indicate their level of sophistication.

The assessment of a unit may require work from an earlier unit in the same strand. However such earlier work will not form the focus of a question. This specification has been designed so that in general the applied modules are supported by the techniques in the pure modules at the same level. Where this is not the case, it is highlighted on the unit's title page.

There are, however, no formal restrictions on the order in which units may be taken.

4.2.2 Constraints

A student's choice of units for these awards is subject to the following restrictions **(a)** to **(d)**.

(a) Mathematics and Further Mathematics Subject Criteria: Compulsory Units

Combinations of units leading to certifications entitled Mathematics and Further Mathematics are required to cover the mathematics subject criteria. The content of this is covered by the following compulsory units.

Mathematics

Advanced Subsidiary GCE: *C1, Introduction to Advanced Mathematics*
C2, Concepts for Advanced Mathematics

Advanced GCE: *C1, Introduction to Advanced Mathematics*
C2, Concepts for Advanced Mathematics
C3, Methods for Advanced Mathematics
C4, Applications of Advanced Mathematics

Further Mathematics

Advanced Subsidiary GCE: *FP1, Further Concepts for Advanced Mathematics*

Advanced GCE: *FP1, Further Concepts for Advanced Mathematics*
FP2, Further Methods for Advanced Mathematics

(b) Balance between Pure and Applied Units

There must be a balance between pure and applied mathematics. There must be one applied unit in AS Mathematics and two applied units in Advanced GCE Mathematics.

Pure Units	Applied Units
<i>C1, Introduction to Advanced Mathematics</i>	<i>DE, Differential Equations</i>
<i>C2, Concepts for Advanced Mathematics</i>	<i>M1, Mechanics 1</i>
<i>C3, Methods for Advanced Mathematics</i>	<i>M2, Mechanics 2</i>
<i>C4, Applications of Advanced Mathematics</i>	<i>M3, Mechanics 3</i>
<i>FP1, Further Concepts for Advanced Mathematics</i>	<i>M4, Mechanics 4</i>
<i>FP2, Further Methods for Advanced Mathematics</i>	<i>S1, Statistics 1</i>
<i>FP3, Further Applications of Advanced Mathematics</i>	<i>S2, Statistics 2</i>
<i>NM, Numerical Methods</i>	<i>S3, Statistics 3</i>
<i>NC, Numerical Computation</i>	<i>S4, Statistics 4</i>
<i>FPT, Further Pure Mathematics with Technology</i>	<i>D1, Decision Mathematics 1</i>
	<i>D2, Decision Mathematics 2</i>
	<i>DC, Decision Mathematics Computation</i>

(c) AS and A2 Units

AS GCE Mathematics consists of three AS units.

Advanced GCE Mathematics consists of
either three AS units and three A2 units
or four AS units and two A2 units.

(d) Mathematics Units not allowed in Further Mathematics

The following units cover the Subject Criteria for Advanced GCE Mathematics and so may **not** contribute to Further Mathematics awards.

C1, Introduction to Advanced Mathematics

C2, Concepts for Advanced Mathematics

C3, Methods for Advanced Mathematics

C4, Applications of Advanced Mathematics

These units may, however, contribute towards awards in Pure Mathematics, but only as described in Sections 4.3.7 and 4.3.8.

4.2.3 Synoptic Assessment

The subject criteria for mathematics require that any combination of units valid for the certification of Advanced GCE Mathematics (7895) or Advanced GCE Pure Mathematics (7898) must include a minimum of 20% synoptic assessment.

Synoptic assessment in mathematics addresses candidates' understanding of the connections between different elements of the subject. It involves the explicit drawing together of knowledge, understanding and skills learned in different parts of the Advanced GCE course through using and applying methods developed at earlier stages of study in solving problems. Making and understanding connections in this way is intrinsic to mathematics.

In this specification the Units *C1* to *C4* contribute over 30% synoptic assessment and so all valid combinations of units meet the synoptic requirement. There is also a further contribution from the two applied units in Advanced GCE Mathematics and from the two further pure units in Advanced GCE Pure Mathematics.

There are no requirements concerning synoptic assessment relating to the certification of Advanced Subsidiary GCE or to Advanced GCE Further Mathematics.

4.3 RULES OF COMBINATION

4.3.1 Advanced Subsidiary GCE Mathematics (3895)

Candidates take one of the following combinations of units:

either *C1*, *C2* and *M1*

or *C1*, *C2* and *S1*

or *C1*, *C2* and *D1*

No other combination of units may be used to claim AS GCE Mathematics.

4.3.2 Advanced GCE Mathematics (7895)

All Advanced GCE Mathematics combinations include:

C1, C2, C3 and C4.

The other two units must be one of the following combinations:

M1, M2; S1, S2; D1, D2; D1, DC; M1, S1; M1, D1; S1, D1

No other combination of units may be used to claim Advanced GCE Mathematics.

The entry codes for these units are repeated here for the convenience of users.

<i>C1</i>	4751	<i>M1</i>	4761	<i>S1</i>	4766	<i>D1</i>	4771
<i>C2</i>	4752	<i>M2</i>	4762	<i>S2</i>	4767	<i>D2</i>	4772
<i>C3</i>	4753					<i>DC</i>	4773
<i>C4</i>	4754						

4.3.3 Advanced Subsidiary GCE Further Mathematics (3896)

Candidates for Advanced Subsidiary GCE Further Mathematics will be expected to have obtained, or to be obtaining concurrently, either Advanced Subsidiary or Advanced GCE Mathematics.

The three units for Advanced Subsidiary GCE Further Mathematics must include:

FP1

The remaining two units may be any two other units subject to the conditions that:

- a total of **six** different units are required for certification in Advanced Subsidiary GCE Mathematics and Advanced Subsidiary GCE Further Mathematics;
- a total of **nine** different units are required for certification in Advanced GCE Mathematics and Advanced Subsidiary GCE Further Mathematics.

Candidates who certificate for Advanced Subsidiary GCE Further Mathematics before certificating for Advanced GCE Mathematics are strongly advised to recertificate for all previously entered qualifications whenever they subsequently make an entry for a qualification.

4.3.4 Advanced GCE Further Mathematics (7896)

Candidates for Advanced GCE Further Mathematics will be expected to have obtained, or to be obtaining concurrently, Advanced GCE Mathematics.

The **six** units for Advanced GCE Further Mathematics must include both:

FP1; FP2

The remaining four units may be any four other units subject to the conditions that:

- a total of **12** different units are required for certification in Advanced GCE Mathematics and Advanced GCE Further Mathematics;
- at least **two** of the four units are A2 units.

4.3.5 Additional Qualification in Advanced Subsidiary GCE Further Mathematics (3897)

Candidates who offer **15** units are eligible for an additional award in Advanced Subsidiary GCE Further Mathematics. Such candidates must have fulfilled the requirements for Advanced GCE Mathematics and Advanced GCE Further Mathematics.

4.3.6 Additional Qualification in Advanced GCE Further Mathematics (7897)

Candidates who offer **18** units are eligible for an additional award in Advanced GCE Further Mathematics. Such candidates must have fulfilled the requirements for Advanced GCE Mathematics and Advanced GCE Further Mathematics.

4.3.7 Advanced Subsidiary GCE Pure Mathematics (3898)

Candidates take one of the following combinations of units:

- either *C1, C2 and FP1*
- or *C1, C2 and NM*
- or *C1, C2 and C3*
- or *C1, C2 and C4*

No other combination of units may be used to claim AS GCE Pure Mathematics.

A qualification in AS Pure Mathematics may **not** be obtained in the same series in combination with any qualification in Mathematics or Further Mathematics.

4.3.8 Advanced GCE Pure Mathematics (7898)

All Advanced GCE Pure Mathematics combinations include:

C1, C2, C3 and C4.

The other two units must be one of the following combinations:

FP1, FP2; FP1, FP3; FP1, NC; NM, FP2; NM, FP3; NM, NC

No other combination of units may be used to claim Advanced GCE Pure Mathematics.

A qualification in Advanced GCE Pure Mathematics may **not** be obtained in the same series in combination with any qualification in Mathematics or Further Mathematics.

4.4 FINAL CERTIFICATION

Each unit is given a grade and a Uniform Mark, using procedures laid down by Ofqual in the document *GCE A and AS Code of Practice*. The relationship between total Uniform Mark and subject grade follows the national scheme.

4.4.1 Certification of Mathematics

Candidates enter for three units of assessment at Advanced Subsidiary GCE. To complete the Advanced GCE candidates must enter a valid combination of six units.

To claim an award at the end of the course, candidates' unit results must be aggregated. This does not happen automatically and Centres must make separate 'certification entries'.

Candidates may request certification entries for:

- either Advanced Subsidiary GCE aggregation
- or Advanced Subsidiary GCE aggregation, bank the result, and complete the A2 assessment at a later date
- or Advanced GCE aggregation
- or Advanced Subsidiary GCE and Advanced GCE aggregation in the same series.

Candidates must enter the appropriate AS and A2 units to qualify for the full Advanced GCE award.

4.4.2 Certification of Mathematics and Further Mathematics: Order of Aggregation

Units that contribute to an award in Advanced GCE Mathematics may not also be used for an award in Advanced GCE Further Mathematics. Candidates who are awarded certificates in both Advanced GCE Mathematics and Advanced GCE Further Mathematics must use unit results from 12 different teaching modules. Candidates who are awarded certificates in both Advanced GCE Mathematics and Advanced Subsidiary GCE Further Mathematics must use unit results from nine different teaching modules. Candidates who are awarded certificates in both Advanced Subsidiary GCE Mathematics and Advanced Subsidiary GCE Further Mathematics must use unit results from six different teaching modules.

When a candidate has requested awards in both Mathematics and Further Mathematics, OCR will adopt the following procedures which follow the *GCE Mathematics Aggregation Rules*, available on the JCQ website.

If certification for Advanced GCE Mathematics is made **at the same time** as the request for a Further Mathematics certification then the valid combination of units will be chosen that gives, in decreasing order of priority:

- the best possible grade for Mathematics;

- the best possible grade for Further Mathematics;
- the highest possible UMS in Mathematics.

Note: In the aggregation process, in order to achieve the best set of grades for a candidate as described above, it is possible that AS GCE Further Mathematics may include some A2 units.

If the only certifications being requested are Advanced Subsidiary GCE Mathematics **at the same time** as Advanced Subsidiary GCE Further Mathematics then the valid combination of units will be chosen that gives, in decreasing order of priority:

- the best possible grade for AS Mathematics;
- the best possible grade for AS Further Mathematics;
- the highest possible UMS in AS Mathematics.

Candidates are strongly advised to recertificate any previously entered qualifications whenever an entry is made for a qualification. This allows the grades awarded to be optimised according to the JCQ rules. For example, if a candidate sits A level Mathematics the units used towards that qualification are ‘locked’ into Mathematics. If the candidate then enters for AS or A level Further Mathematics in a subsequent series, only the unused units are available for use in Further Mathematics. Recertification of all previously entered qualifications unlocks all units and allows the optimisation of the pair of grades awarded.

4.4.3 Awarding of Grades

The Advanced Subsidiary has a weighting of 50% when used in an Advanced GCE award. Advanced GCE awards are based on the aggregation of the weighted Advanced Subsidiary (50%) and A2 (50%) Uniform Marks

Advanced Subsidiary GCE qualifications are awarded on the scale A to E or U (unclassified).
Advanced GCE qualifications are awarded on the scale A* to E or U (unclassified).

4.4.4 Extra Units

A candidate may submit more than the required number of units for a subject award (for example, seven instead of six for an Advanced GCE). In that case the legal combination for that award which is most favourable to the candidate will be chosen.

4.4.5 Enquiries on Results

Candidates will receive their final unit results at the same time as their subject results. In common with other Advanced GCE results, the subject results are at that stage provisional to allow enquiries on results. Enquiries concerning marking are made at the unit level and so only those units taken at the last sitting may be the subject of such appeals. Enquiries are subject to OCR’s general regulations.

4.5 AVAILABILITY

4.5.1 Unit Availability

From September 2013, there is one examination series each year, in June.
In June all units are assessed.

4.5.2 Certification Availability

Certification is available in the June series only.

4.5.3 Shelf-life of Units

Individual unit results, prior to certification of the qualification, have a shelf-life limited only by that of the specifications.

4.6 RE-SITS

4.6.1 Re-sits of Units

There is no limit to the number of times a candidate may re-sit a unit. The best result will count.

4.6.2 Re-sits of Advanced Subsidiary GCE and Advanced GCE

Candidates may take the whole qualification more than once.

4.7 QUESTION PAPERS

4.7.1 Style of Question Papers

The assessment requirements of the various units are summarised in the table in Section 4.1.1.

Most units are assessed by a single question paper lasting 1½ hours. The exceptions are as follows:

- there is also a coursework requirement in *C3*, *DE* and *NM*;
- the examinations for *DC* and *NC* last 2½ hours;
- the examination for *FPT* lasts 2 hours;
- there are two parts to the examination for *C4*. As well as the 1½ hour Paper A (with two sections) there is a comprehension paper lasting 1 hour (Paper B).

Many of the question papers have two sections, A and B. The questions in Section A are short and test techniques. The questions in Section B are longer and also test candidates' ability to follow a more extended piece of mathematics.

In most papers there is no choice of questions but there are options in the papers for the following units: *FP3*, *DE*, *S4* and *NC*.

4.7.2 Use of Language

Candidates are expected to use clear, precise and appropriate mathematical language, as described in Assessment Objective 2.

4.7.3 Standard

Candidates and Centres must note that each A2 unit is assessed at Advanced GCE standard and that no concessions are made to any candidate on the grounds that the examination has been taken early in the course. Centres may disadvantage their candidates by entering them for a unit examination before they are ready.

4.7.4 Thresholds

At the time of setting, each examination paper will be designed so that 50% of the marks are available to grade E candidates, 75% to grade C and 100% to grade A. Typically candidates are expected to achieve about four fifths of the marks available to achieve a grade, giving design grades of: A 80%, B 70%, C 60%, D 50% and E 40%. The actual grading is carried out by the Awarding Committee. They make allowance for examination performance and for any features of a particular paper that only become apparent after it has been taken. Thus some variation from the design grades can be expected in the award.

4.7.5 Calculators

No calculating aids may be used in the examination for Unit CI. For all other units, a graphical calculator is allowed. Computers, and calculators with computer algebra functions, are not permitted in answering any of the units with the exceptions of *DC*, *NC* and *FPT*. The JCQ document *Instructions for conducting examinations*, published annually, contains the regulations regarding the use of calculators in examinations.

4.7.6 Mathematical Formulae and Statistical Tables

A booklet (MF2, January 2007 version) containing Mathematical Formulae and Statistical Tables is available for the use of candidates in all unit examinations.

Details of formulae which candidates are expected to know and the mathematical notation that will be used in question papers are contained in Appendices A and B.

A fuller booklet, entitled *Students' Handbook*, is also available for students' use during the course. This includes all relevant formulae for each unit; those that students are expected to know are identified. The *Students' Handbook* also includes a list of the notation to be used and the statistical tables. Schools and colleges needing copies for their students' use may obtain them from the MEI Office (see Section 7 for the address).

4.8 COURSEWORK

4.8.1 Rationale

The requirements of the following units include a single piece of coursework, which will count for 20% of the assessment of the unit:

C3, Methods for Advanced Mathematics
DE, Differential Equations
NM, Numerical Methods.

In each case the coursework covers particular skills or topics that are, by their nature, unsuitable for assessment within a timed examination but are nonetheless important aspects of their modules.

The work undertaken in coursework is thus of a different kind from that experienced in examinations. As a result of the coursework, students should gain better understanding of how mathematics is applied in real-life situations.

4.8.2 Use of Language

Candidates are expected to use clear, precise and appropriate mathematical language, as described in Assessment Objective 2.

4.8.3 Guidance

Teachers should give students such guidance and instruction as is necessary to ensure that they understand the task they have been given, and know how to set about it. They should explain the basis on which it will be assessed. Teachers should feel free to answer reasonable questions and to discuss students' work with them, until the point where they are working on their final write-up.

A student who takes up and develops advice offered by the teacher should not be penalised for doing so. Teachers should not leave students to muddle along without any understanding of what they are doing. If, however, a student needs to be led all the way through the work, this should be taken into account in the marking, and a note of explanation written on the assessment sheet. Teachers should appreciate that a moderator can usually detect when a student has been given substantial help and that it is to the student's disadvantage if no mention is made of this on the assessment sheet.

Students may discuss a task freely among themselves and may work in small groups. The final write-up must, however, be a student's own work. It is not expected that students will work in larger groups than are necessary.

Coursework may be based on work for another subject (e.g. Geography or Economics), where this is appropriate, but the final write-up must be submitted in a form appropriate for Mathematics.

In order to obtain marks for the assessment domain Oral Communication, students must either give a presentation to the rest of the class, have an interview with the assessor or be engaged in on-going discussion.

4.8.4 Coursework Tasks

Centres are free to develop their own coursework tasks and in that case they may seek advice from OCR about the suitability of a proposed task in relation both to its subject content and its assessment. However, Centres that are new to the scheme are strongly advised to start with tasks in the MEI folder entitled *Coursework Resource Material*. This is available from the MEI Office (see Section 7 for address).

4.8.5 Moderation

Coursework is assessed by the teacher responsible for the module or by someone else approved by the Centre. It should be completed and submitted within a time interval appropriate to the task.

Consequently the teacher has two roles. While the student is working on coursework, the teacher may give assistance as described earlier. However, once the student has handed in the final write-up, the teacher becomes the assessor and no further help may be given. Only one assessment of a piece of coursework is permitted; it may **not** be handed back for improvement or alteration.

The coursework is assessed over a number of domains according to the criteria laid down in the unit specification. The method of assessment of Oral Communication should be stated and a brief report on the outcome written in the space provided on the assessment sheet.

4.8.6 Internal Standardisation

Centres that have more than one teaching group for a particular module must carry out internal standardisation of the coursework produced to ensure that a consistent standard is being maintained across the different groups. This must be carried out in accordance with guidelines from OCR. An important outcome of the internal standardisation process will be the production of a rank order of all candidates.

4.8.7 External Moderation

After coursework is marked by the teacher and internally standardised by the Centre, the marks are then submitted to OCR by the specified date, after which postal moderation takes place in accordance with OCR procedures. Centres must ensure that the work of all the candidates is available for moderation.

As a result of external moderation, the coursework marks of a Centre may be changed, in order to ensure consistent standards between Centres.

4.8.8 Re-Sits

If a unit is re-taken, candidates are offered the option of submitting new coursework (Entry Code Option A) or carrying over the coursework mark from a previous session (Option B).

4.8.9 Minimum Coursework Requirements

If a candidate submits no work for the coursework component, then the candidate should be indicated as being absent from that component on the coursework Mark Sheet submitted to OCR. If a candidate completes any work at all for the coursework component then the work should be assessed according to the criteria and marking instructions and the appropriate mark awarded, which may be 0 (zero).

4.8.10 Authentication

As with all coursework, Centres must be able to verify that the work submitted for assessment is the candidate's own work.

4.9 SPECIAL ARRANGEMENTS

For candidates who are unable to complete the full assessment or whose performance may be unduly affected through no fault of their own, teachers should consult the JCQ booklet *Access Arrangements, Reasonable Adjustments and Special Consideration*. In such cases advice should be sought from OCR as early as possible during the course.

4.10 DIFFERENTIATION

In the question papers differentiation is achieved by setting questions which are designed to assess candidates at their appropriate levels of ability and which are intended to allow candidates to demonstrate what they know, understand and can do.

In coursework, differentiation is by task and by outcome. Students undertake assignments which enable them to display positive achievement.

4.11 GRADE DESCRIPTIONS

The following grade descriptions indicate the level of attainment characteristic of the given grade at Advanced GCE. They give a general indication of the required learning outcomes at each specified grade. The descriptions should be interpreted in relation to the content outlined in the specification; they are not designed to define that content. The grade awarded will depend in practice upon the extent to which the candidate has met the assessment objectives overall. Shortcomings in some aspects of the examination may be balanced by better performances in others.

Grade A

Candidates recall or recognise almost all the mathematical facts, concepts and techniques that are needed, and select appropriate ones to use in a wide variety of contexts.

Candidates manipulate mathematical expressions and use graphs, sketches and diagrams, all with high accuracy and skill. They use mathematical language correctly and proceed logically and rigorously through extended arguments or proofs. When confronted with unstructured problems they can often devise and implement an effective solution strategy. If errors are made in their calculations or logic, these are sometimes noticed and corrected.

Candidates recall or recognise almost all the standard models that are needed, and select appropriate ones to represent a wide variety of situations in the real world. They correctly refer results from calculations using the model to the original situation; they give sensible interpretations of their results in the context of the original realistic situation. They make intelligent comments on the modelling assumptions and possible refinements to the model.

Candidates comprehend or understand the meaning of almost all translations into mathematics of common realistic contexts. They correctly refer the results of calculations back to the given context and usually make sensible comments or predictions. They can distil the essential mathematical information from extended pieces of prose having mathematical content. They can comment meaningfully on the mathematical information.

Candidates make appropriate and efficient use of contemporary calculator technology and other permitted resources, and are aware of any limitations to their use. They present results to an appropriate degree of accuracy.

Grade C

Candidates recall or recognise most of the mathematical facts, concepts and techniques that are needed, and usually select appropriate ones to use in a variety of contexts.

Candidates manipulate mathematical expressions and use graphs, sketches and diagrams, all with a reasonable level of accuracy and skill. They use mathematical language with some skill and sometimes proceed logically through extended arguments or proofs. When confronted with unstructured problems they sometimes devise and implement an effective and efficient solution strategy. They occasionally notice and correct errors in their calculations.

Candidates recall or recognise most of the standard models that are needed and usually select appropriate ones to represent a variety of situations in the real world. They often correctly refer results from calculations using the model to the original situation; they sometimes give sensible interpretations of their results in the context of the original realistic situation. They sometimes make intelligent comments on the modelling assumptions and possible refinements to the model.

Candidates comprehend or understand the meaning of most translations into mathematics of common realistic contexts. They often correctly refer the results of calculations back to the given context and sometimes make sensible comments or predictions. They distil much of the essential mathematical information from extended pieces of prose having mathematical content. They give some useful comments on this mathematical information.

Candidates usually make appropriate and efficient use of contemporary calculator technology and other permitted resources, and are sometimes aware of any limitations to their use. They usually present results to an appropriate degree of accuracy.

Grade E

Candidates recall or recognise some of the mathematical facts, concepts and techniques that are needed, and sometimes select appropriate ones to use in some contexts.

Candidates manipulate mathematical expressions and use graphs, sketches and diagrams, all with some accuracy and skill. They sometimes use mathematical language correctly and occasionally proceed logically through extended arguments or proofs.

Candidates recall or recognise some of the standard models that are needed and sometimes select appropriate ones to represent a variety of situations in the real world. They sometimes correctly refer results from calculations using the model to the original situation; they try to interpret their results in the context of the original realistic situation.

Candidates sometimes comprehend or understand the meaning of translations in mathematics of common realistic contexts. They sometimes correctly refer the results of calculations back to the given context and attempt to give comments or predictions. They distil some of the essential mathematical information from extended pieces of prose having mathematical content. They attempt to comment on this mathematical information.

Candidates often make appropriate and efficient use of contemporary calculator technology and other permitted resources. They often present results to an appropriate degree of accuracy.

5 Subject Content

5.1 ASSUMED KNOWLEDGE

There is no formal prerequisite for a student wishing to embark on MEI Structured Mathematics.

The unit specifications are written with the same assumption about prior knowledge as that used for the subject criteria, that students embarking on AS and Advanced GCE study in Mathematics are expected to have achieved at least grade C in GCSE Mathematics, or its equivalent, and to have covered all the material in the Intermediate Tier*. Consequently everything which is in the National Curriculum up to and including that level is also implicit in this specification. In a number of cases such material is included in the specification for clarity and completeness and is indicated by an asterisk; such material will not form the focus of an examination question.

*This refers to the Intermediate tier of GCSE Mathematics at the time when the subject criteria were written. See the document *Assumed Knowledge for GCE Mathematics* on the Mathematics pages of the OCR website (www.ocr.org.uk) for more details.

5.2 MODELLING

The process of modelling is illustrated by the flow chart below.

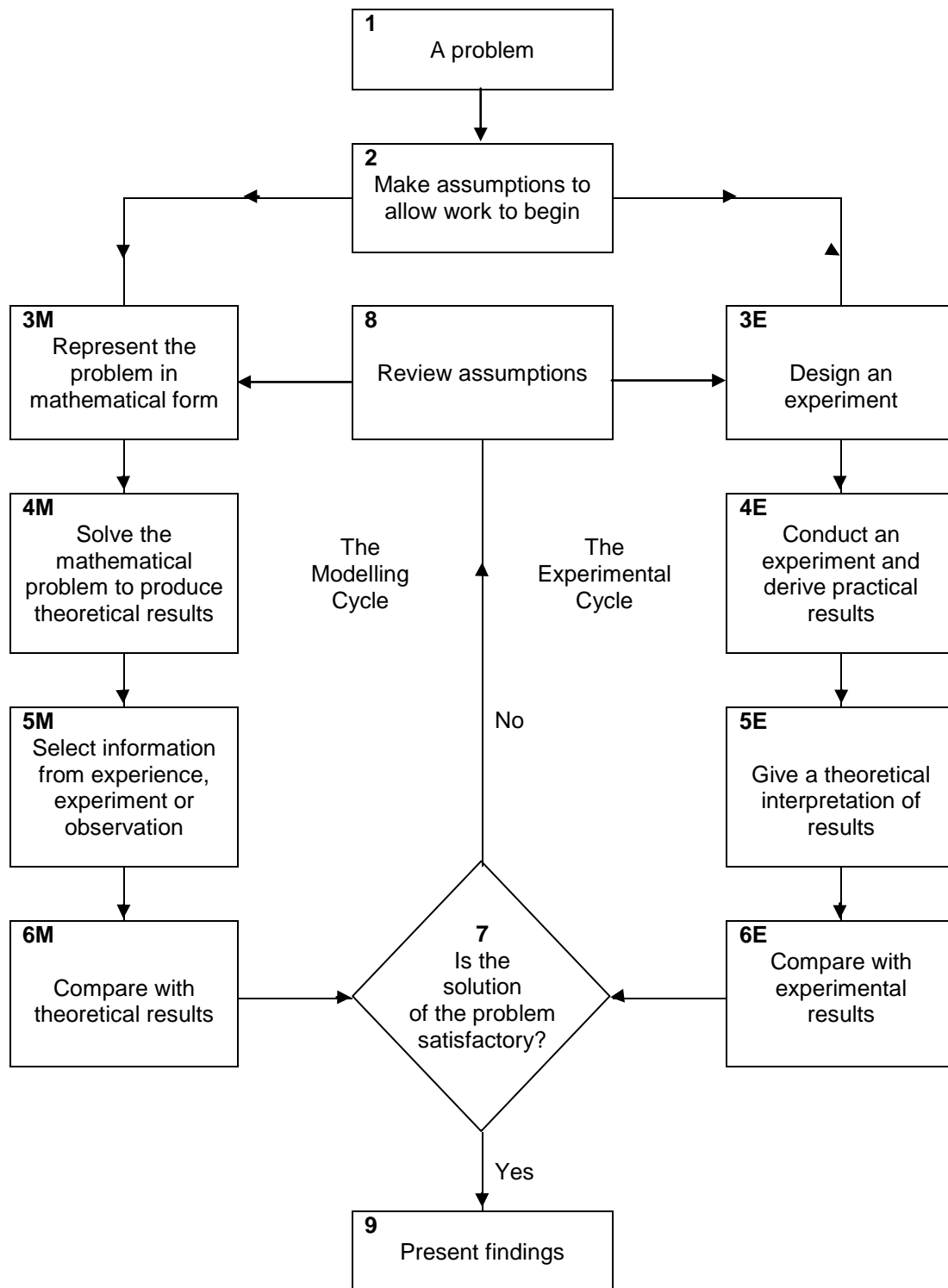

5.3 COMPETENCE STATEMENTS

The unit specifications include competence statements. These are designed to help users by clarifying the requirements, but the following three points need to be noted:

- work that is covered by a competence statement may be asked in an examination question without further assistance being given;
- examination questions may require candidates to use two or more competence statements at the same time without further assistance being given;
- where an examination question requires work that is not covered by a competence statement, sufficient guidance will be given within the question.

Competence statements have an implied prefix of the words: ‘A student should ...’

The letters used in assigning reference numbers to competence statements are as follows.

a	algebra	A	Algorithms
b	bivariate data	B	
c	calculus	C	Curves, Curve sketching
d	dynamics	D	Data presentation
e	equations	E	
f	functions	F	
g	geometry, graphs	G	Centre of mass
h	Hooke’s law	H	Hypothesis testing
i	impulse and momentum	I	Inference
j	complex numbers	J	
k	kinematics	K	
l		L	Linear programming
m	matrices	M	Matchings
n	Newton’s laws	N	Networks
o	oscillations (SHM)	O	
p	mathematical processes (modelling, proof, etc)	P	Polar coordinates
q	dimensions (quantities)	Q	
r	rotation	R	Random variables
s	sequences and series	S	
t	trigonometry	T	Number Theory
u	probability (uncertainty)	U	Errors (uncertainty)
v	vectors	V	
w	work, energy and power	W	
x	experimental design	X	Critical path analysis
y	projectiles	Y	
z		Z	Simulation

6 Unit Specifications

6.1 INTRODUCTION TO ADVANCED MATHEMATICS, C1 (4751) AS

Objectives

To build on and develop the techniques students have learnt at GCSE so that they acquire the fluency required for advanced work.

Assessment

Examination (72 marks)
1 hour 30 minutes.
The examination paper has two sections.

Section A: 8-10 questions, each worth no more than 5 marks.
Section Total: 36 marks

Section B: three questions, each worth about 12 marks.
Section Total: 36 marks

Assumed Knowledge

Candidates are expected to know the content of Intermediate Tier GCSE*.

*See note on page 34.

Subject Criteria

The Units *C1* and *C2* are required for Advanced Subsidiary GCE Mathematics in order to ensure coverage of the subject criteria.

The Units *C1*, *C2*, *C3* and *C4* are required for Advanced GCE Mathematics in order to ensure coverage of the subject criteria.

Calculators

No calculator is allowed in the examination for this module.

In the MEI Structured Mathematics specification, graphical calculators are allowed in the examinations for all units except *C1*.

INTRODUCTION TO ADVANCED MATHEMATICS, C1		
Specification	Ref.	Competence Statements

Competence statements marked with an asterisk * are assumed knowledge and will not form the basis of any examination questions. These statements are included for clarity and completeness.

MATHEMATICAL PROCESSES

Proof

The construction and presentation of mathematical arguments through appropriate use of logical deduction and precise statements involving correct use of symbols and appropriate connecting language pervade the whole of mathematics at this level. These skills, and the Competence Statements below, are requirements of all the modules in these specifications.

Mathematical argument	C1p1	Understand and be able to use mathematical language, grammar and notation with precision.
	2	Be able to construct and present a mathematical argument.

Modelling

Modelling pervades much of mathematics at this level and a basic understanding of the processes involved will be assumed in all modules

The Modelling Cycle

The modelling cycle.	C1p3	Be able to recognise the essential elements in a modelling cycle.
----------------------	------	---

INTRODUCTION TO ADVANCED MATHEMATICS, C1

Ref.	Notes	Notation	Exclusions
------	-------	----------	------------

C1p1	Equals, does not equal, identically equals, therefore, because, implies, is implied by, necessary, sufficient	=, ≠, ∴, ⇒, ⇐, ⇔	
------	---	---------------------	--

2	Construction and presentation of mathematical arguments through appropriate use of logical deduction and precise statements involving correct use of symbols and appropriate connecting language.		
---	---	--	--

3	The elements are illustrated on the diagram in Section 5.2.		
---	---	--	--

INTRODUCTION TO ADVANCED MATHEMATICS, C1

Specification	Ref.	Competence Statements
----------------------	-------------	------------------------------

ALGEBRA

The basic language of algebra.	C1a1	Know and be able to use vocabulary and notation appropriate to the subject at this level.
Solution of equations.	2	* Be able to solve linear equations in one unknown.
	3	Be able to change the subject of a formula.
	4	Know how to solve an equation graphically.
	5	Be able to solve quadratic equations.
	6	Be able to find the discriminant of a quadratic function and understand its significance.
	7	Know how to use the method of completing the square to find the line of symmetry and turning point of the graph of a quadratic function.
	8	* Be able to solve linear simultaneous equations in two unknowns.
	9	Be able to solve simultaneous equations in two unknowns where one equation is linear and one is of 2nd order.
	10	Know the significance of points of intersection of two graphs with relation to the solution of simultaneous equations.
	Inequalities.	11
12		Be able to solve quadratic inequalities.
Surds.	13	Be able to use and manipulate surds.
	14	Be able to rationalise the denominator of a surd.
Indices.	15	Understand and be able to use the laws of indices for all rational exponents.
	16	Understand the meaning of negative, fractional and zero indices.

INTRODUCTION TO ADVANCED MATHEMATICS, C1

Ref.	Notes	Notation	Exclusions
------	-------	----------	------------

ALGEBRA

C1a1	Expression, function, constant, variable, term, coefficient, index, linear, identity, equation.	$f(x)$	Formal treatment of functions.
2	Including those containing brackets and fractions.		
3	Including cases where the new subject appears on both sides of the original formula, and cases involving squares and square roots.		
4	Including repeated roots.		
5	By factorising, completing the square, using the formula and graphically.		
6	The condition for distinct real roots is: Discriminant > 0 The condition for repeated roots is: Discriminant $= 0$	Discriminant $= b^2 - 4ac$.	Complex roots.
7	The graph of $y = a(x + p)^2 + q$ has a turning point at: $(-p, q)$ and a line of symmetry $x = -p$		
8	By elimination, substitution and graphically.		
9	Analytical solution by substitution.		
10			
11	Including those containing brackets and fractions.		
12	Algebraic and graphical treatment of quadratic inequalities.		Examples involving quadratics which cannot be factorised.
13			
14	e.g. $\frac{1}{5 + \sqrt{3}} = \frac{5 - \sqrt{3}}{22}$		
15	$x^a \times x^b = x^{a+b}$, $x^a \div x^b = x^{a-b}$, $(x^a)^n = x^{an}$		
16	$x^{-a} = \frac{1}{x^a}$, $x^{\frac{1}{a}} = \sqrt[a]{x}$, $x^0 = 1$		

INTRODUCTION TO ADVANCED MATHEMATICS, C1

Specification	Ref.	Competence Statements
---------------	------	-----------------------

COORDINATE GEOMETRY

The coordinate geometry of straight lines.	C1g1	*Know the equation $y = mx + c$.
	2	Know how to specify a point in Cartesian coordinates in two dimensions.
	3	Know the relationship between the gradients of parallel lines and perpendicular lines.
	4	* Be able to calculate the distance between two points.
	5	* Be able to find the coordinates of the midpoint of a line segment joining two points.
	6	Be able to form the equation of a straight line.
	7	Be able to draw a line when given its equation.
	8	Be able to find the point of intersection of two lines.
The coordinate geometry of curves.	9	* Know how to plot a curve given its equation.
	10	Know how to find the point of intersection of a line and a curve.
	11	Know how to find the point(s) of intersection of two curves.
	12	Understand that the equation of a circle, centre $(0, 0)$, radius r is $x^2 + y^2 = r^2$
	13	Understand that $(x - a)^2 + (y - b)^2 = r^2$ is the equation of a circle with centre (a, b) and radius r .
	14	Know that: <ul style="list-style-type: none"> – the angle in a semicircle is a right angle; – the perpendicular from the centre of a circle to a chord bisects the chord; – the tangent to a circle at a point is perpendicular to the radius through that point.

INTRODUCTION TO ADVANCED MATHEMATICS, C1

Ref.	Notes	Notation	Exclusions
------	-------	----------	------------

COORDINATE GEOMETRY

C1g1

2

3 For parallel lines $m_1 = m_2$.
For perpendicular lines $m_1 m_2 = -1$.

4

5

6 $y - y_1 = m(x - x_1)$, $ax + by + c = 0$,
 $\frac{y - y_1}{y_2 - y_1} = \frac{x - x_1}{x_2 - x_1}$.

7 By using gradient and intercept as well as by plotting points.

8 By solution of simultaneous equations.

9 By making a table of values.

10

11

Equations of order greater than 2.

12

13

14 These results may be used in the context of coordinate geometry.

Formal proofs of these results.

INTRODUCTION TO ADVANCED MATHEMATICS, C1

Specification	Ref.	Competence Statements
---------------	------	-----------------------

POLYNOMIALS

Basic operations on polynomials.	C1f1	Know how to add, subtract, multiply and divide polynomials.
The factor theorem.	2	Understand the factor theorem and know how to use it to factorise a polynomial.
	3	Know how to use the factor theorem to solve a polynomial equation.
	4	Know how to use the factor theorem to find an unknown coefficient.
The remainder theorem.	5	Understand the remainder theorem and know how to use it.
Graphs.	6	Know how to sketch the graphs of polynomial functions.
Binomial expansions.	7	Know how to use Pascal's triangle in the binomial expansion of $(a + x)^n$ where n is a positive integer.
	8	Know the notations ${}^n C_r$ and $\binom{n}{r}$, and their relationship to Pascal's triangle.
	9	Know how to use ${}^n C_r$ in the binomial expansion of $(a + b)^n$ where n is a positive integer.

CURVE SKETCHING

Vocabulary.	C1C1	Understand the difference between sketching and plotting a curve.
Quadratic curves.	2	Know how to sketch a quadratic curve with its equation in completed square form.
Polynomial curves.	3	Know how to sketch the curve of a polynomial in factorised form.
Transformations.	4	Know how to sketch curves of the forms $y = f(x) + a$ and $y = f(x - b)$, given the curve of $y = f(x)$.

INTRODUCTION TO ADVANCED MATHEMATICS, C1

Ref.	Notes	Notation	Exclusions
------	-------	----------	------------

POLYNOMIALS

C1f1	Expanding brackets and collecting like terms. Division by linear expressions only.		Division by non-linear expressions.
2	$f(a) = 0 \Leftrightarrow (x - a)$ is a factor of $f(x)$.		
3	$f(a) = 0 \Rightarrow x = a$ is a root of $f(x) = 0$.		Equations of degree > 4 .
4	Use of factors to determine zeros $(x - a)$ is a factor of $f(x) \Rightarrow f(a) = 0$.		
5	The remainder when $f(x)$ is divided by $(x - a)$ is $f(a)$.		
6	By factorising.		Functions of degree > 4 .
7			
8	The meaning of the term factorial.	${}^n C_r = \binom{n}{r}$ $= \frac{n!}{r!(n-r)!}$ $n! = 1.2.3..n$ ${}^n C_0 = {}^n C_n = 1$	
9			

CURVE SKETCHING

C1C1	Where appropriate, candidates will be expected to identify where a curve crosses the coordinate axes (in cases where the points of intersection are known or easily found), and its behaviour for large numerical values of x .		Asymptotes.
2	The curve $y = a(x + p)^2 + q$ has a minimum at $(-p, q)$.		
3	Including cases of repeated roots.		Functions of degree > 4 .
4	Vector notation may be used for a translation. Including working with sketches of graphs where functions are not defined algebraically. Other transformations are covered in C3f2-5.	$\begin{pmatrix} b \\ a \end{pmatrix}$	

6.2 CONCEPTS FOR ADVANCED MATHEMATICS, C2 (4752) AS

Objectives

To introduce students to a number of topics which are fundamental to the advanced study of mathematics.

Assessment

Examination (72 marks)
1 hour 30 minutes.
The examination paper has two sections.

Section A: 8-10 questions, each worth no more than 5 marks.
Section Total: 36 marks

Section B: three questions, each worth about 12 marks.
Section Total: 36 marks

Assumed Knowledge

Candidates are expected to know the content of Intermediate Tier GCSE* and *C1*.

*See note on page 34.

Subject Criteria

The Units *C1* and *C2* are required for Advanced Subsidiary GCE Mathematics in order to ensure coverage of the subject criteria.

The Units *C1*, *C2*, *C3* and *C4* are required for Advanced GCE Mathematics in order to ensure coverage of the subject criteria.

Calculators

In the MEI Structured Mathematics specification, no calculator is allowed in the examination for *C1*. For all other units, including this one, a graphical calculator is allowed.

CONCEPTS FOR ADVANCED MATHEMATICS, C2

Specification	Ref.	Competence Statements
---------------	------	-----------------------

ALGEBRA

Logarithms.	C2a1	Understand the meaning of the word logarithm.
	2	Understand the laws of logarithms and how to apply them.
	3	Know the values of $\log_a a$ and $\log_a 1$.
	4	Know how to convert from an index to a logarithmic form and vice versa.
	5	Know the function $y = a^x$ and its graph.
	6	Be able to solve an equation of the form $a^x = b$.
	7	Know how to reduce the equations $y = ax^n$ and $y = ab^x$ to linear form and, using experimental data, to draw a graph to find values of a, n and a, b .

SEQUENCES AND SERIES

Definitions of sequences.	C2s1	Know what a sequence of numbers is and the meaning of finite and infinite sequences.
	2	Know that a sequence can be generated using a formula for the k^{th} term, or a recurrence relation of the form $a_{k+1} = f(a_k)$.
	3	Know what a series is.
	4	Be familiar with \sum notation.
	5	Know and be able to recognise the periodicity of sequences.
	6	Know the difference between convergent and divergent sequences.

Arithmetic series.	7	Know what is meant by arithmetic series and sequences.
	8	Be able to use the standard formulae associated with arithmetic series and sequences.

Geometric series.	9	Know what is meant by geometric series and sequences.
	10	Be able to use the standard formulae associated with geometric series and sequences.
	11	Know the condition for a geometric series to be convergent and be able to find its sum to infinity.
	12	Be able to solve problems involving arithmetic and geometric series and sequences.

CONCEPTS FOR ADVANCED MATHEMATICS, C2

Ref.	Notes	Notation	Exclusions
------	-------	----------	------------

ALGEBRA

C2a1	$y = \log_a x \Leftrightarrow a^y = x$		
2	$\log_a(xy) = \log_a x + \log_a y$ $\log_a\left(\frac{x}{y}\right) = \log_a x - \log_a y$ $\log_a(x^k) = k \log_a x$		Change of base of logarithms.
3	$\log_a a = 1, \log_a 1 = 0$		
4	$x = a^n \Leftrightarrow n = \log_a x$		
5	For $a \geq 1$.		
6	By taking logarithms of both sides.		
7	By taking logarithms of both sides and comparing with the equation $y = mx + c$.		

SEQUENCES AND SERIES

C2s1			
2	e.g. $a_k = 2 + 3k$; $a_{k+1} = a_k + 3$ with $a_1 = 5$.	k^{th} term: a_k	
3	With reference to the corresponding sequence.		
4	Including the sum of the first n natural numbers.		
5			
6	e.g. convergent sequence $a_k = 3 - \frac{1}{k}$ e.g. divergent sequence $a_k = 1 + 2k^2$		Formal tests for convergence.
7	The term arithmetic progression (AP) may also be used.	1st term, a Last term, l Common difference, d .	
8	The n th term, the sum to n terms.		
9	The term geometric progression (GP) may also be used.	1st term, a Common ratio, r .	
10	The n th term, the sum to n terms.	S_n	
11	Candidates will be expected to be familiar with the modulus sign in the condition for convergence.	$S_\infty = \frac{a}{1-r}, r < 1$	
12	These may involve the solution of quadratic and simultaneous equations.		

CONCEPTS FOR ADVANCED MATHEMATICS, C2

Specification	Ref.	Competence Statements
---------------	------	-----------------------

TRIGONOMETRY

Basic trigonometry.	C2t1	* Know how to solve right-angled triangles using trigonometry.
The sine, cosine and tangent functions.	2	Be able to use the definitions of $\sin \theta$ and $\cos \theta$ for any angle.
	3	Know the graphs of $\sin \theta$, $\cos \theta$ and $\tan \theta$ for all values of θ , their symmetries and periodicities.
	4	Know the values of $\sin \theta$, $\cos \theta$ and $\tan \theta$ when θ is 0° , 30° , 45° , 60° , 90° and 180° .
Identities.	5	Be able to use $\tan \theta = \frac{\sin \theta}{\cos \theta}$ (for any angle).
	6	Be able to use the identity $\sin^2 \theta + \cos^2 \theta = 1$.
	7	Be able to solve simple trigonometric equations in given intervals.
Area of a triangle.	8	Know and be able to use the fact that the area of a triangle is given by $\frac{1}{2} ab \sin C$.
The sine and cosine rules.	9	Know and be able to use the sine and cosine rules.
Radians.	10	Understand the definition of a radian and be able to convert between radians and degrees.
	11	Know and be able to find the arc length and area of a sector of a circle, when the angle is given in radians.

CONCEPTS FOR ADVANCED MATHEMATICS, C2

Ref.	Notes	Notation	Exclusions
------	-------	----------	------------

TRIGONOMETRY

C2t1

2	e.g. by reference to the unit circle.		
3	Their use to find angles outside the first quadrant.		
4	Exact values may be expected.		
5	e.g. solve $\sin \theta = 3 \cos \theta$ for $0^\circ \leq \theta \leq 360^\circ$.		
6	e.g. simple application to solution of equations.		
7	e.g. $\sin \theta = 0.5 \Leftrightarrow \theta = 30^\circ, 150^\circ$ in $[0^\circ, 360^\circ]$.	$\arcsin x$ $\arccos x$ $\arctan x$	Principal values (see C4) General solutions.
8			
9	Use of bearings may be required.		
10			
11	The results $s = r\theta$ and $A = \frac{1}{2}r^2\theta$ where θ is measured in radians.		

CONCEPTS FOR ADVANCED MATHEMATICS, C2

Specification	Ref.	Competence Statements
---------------	------	-----------------------

CALCULUS

The basic process of differentiation.	C2c1	Know that the gradient of a curve at a point is given by the gradient of the tangent at the point.
	2	Know that the gradient of the tangent is given by the limit of the gradient of a chord.
	3	Know that the gradient function $\frac{dy}{dx}$ gives the gradient of the curve and measures the rate of change of y with respect to x .
Applications of differentiation to the graphs of functions.	4	Be able to differentiate $y = kx^n$ where k is a constant, and the sum of such functions.
	5	Be able to find second derivatives.
	6	Be able to use differentiation to find stationary points on a curve: maxima, minima and points of inflection.
	7	Understand the terms increasing function and decreasing function.
	8	Be able to find the equation of a tangent and normal at any point on a curve.
Integration as the inverse of differentiation.	9	Know that integration is the inverse of differentiation.
	10	Be able to integrate functions of the form kx^n where k is a constant and $n \neq -1$, and the sum of such functions.
	11	Know what are meant by indefinite and definite integrals.
	12	Be able to evaluate definite integrals.
	13	Be able to find a constant of integration given relevant information.
Integration to find the area under a curve.	14	Know that the area under a graph can be found as the limit of a sum of areas of rectangles.
	15	Be able to use integration to find the area between a graph and the x -axis.
	16	Be able to find an approximate value of a definite integral using the trapezium rule, and comment sensibly on its accuracy.

CURVE SKETCHING

Stationary points.	C2C1	Be able to use stationary points when curve sketching.
Stretches.	2	Know how to sketch curves of the form $y = af(x)$ and $y = f(ax)$, given the curve of: $y = f(x)$.

CONCEPTS FOR ADVANCED MATHEMATICS, C2

Ref.	Notes	Notation	Exclusions
------	-------	----------	------------

CALCULUS

C2c1

2		$\frac{d\phi}{d\delta} = \lim_{\delta x \rightarrow 0} \frac{y}{x}$	
3	The terms increasing function and decreasing function.		
4	Simple cases of differentiation from first principles. Including rational values of n .	$f'(x) = \lim_{h \rightarrow 0} \left(\frac{f(x+h) - f(x)}{h} \right)$	
5		$f''(x) = \frac{d^2 y}{dx^2}$	
6			
7	In relation to the sign of $\frac{dy}{dx}$.		
8			
9			
10			
11			
12	e.g. $\int_1^3 (3x^2 + 5x - 1) dx$.		
13	e.g. Find y when $x = 2$ given that $\frac{dy}{dx} = 2x + 5$ and $y = 7$ when $x = 1$.		
14	General understanding only.		Formal proof.
15	Includes areas of regions partly above and partly below the x -axis.		
16	Comments on the error will be restricted to consideration of its direction and made with reference to the shape of the curve.		Repeated applications of the trapezium rule (see C4).

CURVE SKETCHING

C2C1	Including distinguishing between them.		
2	Simple cases only e.g. Given $f(x) = \sin x$, sketch $y = \sin(2x)$ or $y = 3 \sin x$.		Combined transformations (see C3f2).

6.3 METHODS FOR ADVANCED MATHEMATICS, C3 (4753) A2

Objectives

To build on and develop the techniques students have learnt at AS Level, with particular emphasis on the calculus.

Assessment

Examination (72 marks)
1 hour 30 minutes
The examination paper has two sections.

Section A: 5-7 questions, each worth at most 8 marks.
Section Total: 36 marks

Section B: two questions, each worth about 18 marks.
Section Total: 36 marks

Coursework (18 marks)

Candidates are required to undertake a piece of coursework on the numerical solution of equations (see pages 62 to 65).

Assumed Knowledge

Candidates are expected to know the content for Units *C1* and *C2*.

Subject Criteria

The Units *C1* and *C2* are required for Advanced Subsidiary GCE Mathematics in order to ensure coverage of the subject criteria.

The Units *C1*, *C2*, *C3* and *C4* are required for Advanced GCE Mathematics in order to ensure coverage of the subject criteria.

Calculators

In the MEI Structured Mathematics specification, no calculator is allowed in the examination for *C1*. For all other units, including this one, a graphical calculator is allowed.

METHODS FOR ADVANCED MATHEMATICS, C3

Specification	Ref.	Competence Statements
---------------	------	-----------------------

PROOF

Methods of proof.	C3p1	Understand, and be able to use, proof by direct argument, exhaustion and contradiction.
	2	Be able to disprove a conjecture by the use of a counter example.

EXPONENTIALS AND NATURAL LOGARITHMS

The exponential and natural logarithm.	C3a1	Understand and be able to use the simple properties of exponential and logarithmic functions including the functions e^x and $\ln x$.
Functions.	2	Know the relationship between $\ln x$ and e^x .
	3	Know the graphs of $y = \ln x$ and $y = e^x$.
	4	Be able to solve problems involving exponential growth and decay.

FUNCTIONS

The language of functions.	C3f1	Understand the definition of a function, and the associated language.
	2	Know the effect of combined transformations on a graph and be able to form the equation of the new graph.
	3	Be able, given the graph of $y = f(x)$, to sketch related graphs.
	4	Be able to apply transformations to the basic trigonometrical functions.
	5	Know how to find a composite function, $gf(x)$.
	6	Know the conditions necessary for the inverse of a function to exist and how to find it (algebraically and graphically).
	7	Understand the functions arcsin, arccos and arctan, their graphs and appropriate restricted domains.
	8	Understand what is meant by the terms odd, even and periodic functions and the symmetries associated with them.
The modulus function.	9	Understand the modulus function.
	10	Be able to solve simple inequalities containing a modulus sign.

METHODS FOR ADVANCED MATHEMATICS, C3

Ref.	Notes	Notation	Exclusions
------	-------	----------	------------

PROOF

C3p1

2

EXPONENTIALS AND NATURAL LOGARITHMS

C3a1

$$\log_e x = \ln x$$

2 Simplifying expressions involving exponentials and logarithms.

3

4

FUNCTIONS

C3f1 Many-to-one, one-to-many, one-to-one, mapping, object, image, domain, codomain, range, odd, even, periodic.

2 Translation parallel to the x -axis.
 Translation parallel to the y -axis.
 Stretch parallel to the x -axis.
 Stretch parallel to the y -axis.
 Reflection in the x -axis.
 Reflection in the y -axis.
 Combinations of these transformations.

Translation vector
 $\begin{pmatrix} a \\ b \end{pmatrix}$

3 $y = f(x \pm a)$ $y = f(x) \pm a$
 $y = f(ax)$ $y = af(x)$ for $a > 0$
 $y = f(-x)$ $y = -f(x)$.

4 Translations parallel to the x - and y -axes.
 Stretches parallel to the x - and y -axes.
 Reflections in the x - and y -axes.

5

6 The use of reflection in the line $y = x$.
 e.g. $\ln x$ ($x > 0$) is the inverse of e^x .

7 Their graphs and periodicity.

8 e.g. x^n for integer values of n .

9 Graphs of linear functions involving a single modulus sign.

10 Including the use of inequalities of the form $|x - a| \leq b$ to express upper and lower bounds, $a \pm b$, for the value of x .

Inequalities involving more than one modulus sign.

METHODS FOR ADVANCED MATHEMATICS, C3

Specification	Ref.	Competence Statements
---------------	------	-----------------------

CALCULUS

The product, quotient and chain rules.	C3c1	Be able to differentiate the product of two functions.
	2	Be able to differentiate the quotient of two functions.
	3	Be able to differentiate composite functions using the chain rule.
	4	Be able to find rates of change using the chain rule.
Inverse functions.	5	Be able to differentiate an inverse function.
Implicit differentiation.	6	Be able to differentiate a function defined implicitly.
Differentiation of further functions.	7	Be able to differentiate e^{ax} and $\ln x$.
	8	Be able to differentiate the trigonometrical functions: $\sin x$; $\cos x$; $\tan x$.
Integration by substitution.	9	Be able to use integration by substitution in cases where the process is the reverse of the chain rule.
	10	Be able to use integration by substitution in other cases.
Integration of further functions.	11	Be able to integrate $\frac{1}{x}$.
	12	Be able to integrate e^{ax} .
	13	Be able to integrate $\sin x$ and $\cos x$.
Integration by parts.	14	Be able to use the method of integration by parts in cases where the process is the reverse of the product rule.
	15	Be able to apply integration by parts to $\ln x$.

METHODS FOR ADVANCED MATHEMATICS, C3

Ref.	Notes	Notation	Exclusions
------	-------	----------	------------

CALCULUS

C3c1			
2			
3			
4			
5	$\frac{dy}{dx} = \frac{1}{\left(\frac{dx}{dy}\right)}$		
6	e.g. $\ln y = 1 - x^2$.		
7			
8	Including their sums and differences.		
9	e.g. $(1 + 2x)^8$, $x(1 + x^2)^8$, xe^{x^2} , $\frac{1}{2x + 3}$ Where appropriate, recognition may replace substitution.		
10	Simple cases only, e.g. $\frac{x}{2x + 1}$.		
11			
12			
13			Integrals involving arcsin, arccos and arctan forms.
14	e.g. xe^x .	Integrals requiring more than one application of the method. Products of e^x and trigonometric functions.	
15			

METHODS FOR ADVANCED MATHEMATICS, C3

Specification	Ref.	Competence Statements
---------------	------	-----------------------

NUMERICAL METHODS

This topic will not be assessed in the examination for C3, since it is the subject of the coursework.

Change of sign.	C3e1	Be able to locate the roots of $f(x) = 0$ by considering changes of sign of $f(x)$ in an interval of x in which $f(x)$ is continuous.
	2	Be aware of circumstances under which change of sign methods may fail to give an expected root or may give a false root.
Fixed point iteration.	3	Be able to carry out a fixed point iteration after rearranging an equation into the form $x = g(x)$.
	4	Understand that not all iterations converge to a particular root of an equation.
The Newton-Raphson method.	5	Be able to use the Newton-Raphson method to solve an equation.
Error Bounds.	6	Appreciate the need to establish error bounds when applying a numerical method.
Geometrical interpretation.	7	Be able to give a geometrical interpretation both of the processes involved and of their algebraic representation.

METHODS FOR ADVANCED MATHEMATICS, C3

Ref.	Notes	Notation	Exclusions
------	-------	----------	------------

NUMERICAL METHODS

This topic will not be assessed in the examination for C3, since it is the subject of the coursework.

C3e1 e.g. decimal search.

2 e.g. when the curve of $y = f(x)$ touches the x -axis.
e.g. when the curve of $y = f(x)$ has a vertical asymptote.

3 e.g. $x^3 - x - 4 = 0$ written as $x = \sqrt[3]{x+4}$ and so give rise
to the iteration $x_{n+1} = \sqrt[3]{x_n + 4}$.
Staircase and cobweb diagrams.

4 The iteration $x_{n+1} = g(x_n)$ converges to a root at $x = a$ if Proof.
 $|g'(a)| < 1$ providing the iteration starts sufficiently close to a .

5

6 Error bounds should be established within the numerical
method and not by reference to an already known solution.

7

Methods for Advanced Mathematics (C3) Coursework: Solution of Equations by Numerical Methods

Rationale

The assessment of this unit includes a coursework task (Component 2) involving the solution of equations by three different numerical methods.

The aims of this coursework are that students should appreciate the principles of numerical methods and at the same time be provided with useful equation solving techniques.

The objectives are:

- that students should be able to solve equations efficiently, to any required level of accuracy, using numerical methods;
- that in doing so they will appreciate how to use appropriate technology, such as calculators and computers, as a mathematical tool and have an awareness of its limitations;
- that they show geometrical awareness of the processes involved.

This task represents 20% of the assessment and the work involved should be consistent with that figure, both in quality and level of sophistication.

Numerical methods should be seen as complementing analytical ones and not as providing alternative (and less accurate) ways of doing the same job. Thus, equations which have simple analytical solutions should not be selected. Accuracy should be established from within the numerical working and not by reference to an exact solution obtained analytically.

The intention of this piece of coursework is not merely to solve equations; students should be encouraged to treat it as an investigation and to choose their own equations.

Requirements

1 Students must solve equations by the following three methods:

- Systematic search for a change of sign using one of the methods: bisection; decimal search; linear interpolation. One root is to be found.
- Fixed point iteration using the Newton-Raphson method. The equation selected must have at least two roots and all roots are to be found.
- Fixed point iteration after rearranging the equation $f(x) = 0$ into the form $x = g(x)$. One root is to be found.

A different equation must be used for each method.

In addition, a student's write-up must meet the following requirements.

- 2 One root of one of the equations must be found by all three methods. The methods used should then be compared in terms of their efficiency and ease of use.
- 3 The write-up must include graphical illustrations of how the methods work on the student's equations.
- 4 A student is expected to be able to give error bounds for the value of any root. This must be demonstrated in the case of the change of sign method (maximum possible error 0.5×10^{-3}), and for one of the roots found by the Newton-Raphson method (required accuracy five significant figures).
- 5 For each method an example should be given of an equation where the method fails: that is, an expected root is not obtained, a root is not found or a false root is obtained. There must be an explanation, illustrated graphically, of why this happens. In this situation it is acceptable to use equations with known analytical solutions provided they are not trivial.

Notation and Language

Students are expected to use correct notation and terminology. This includes distinguishing between the words function and equation, and between root and solution.

- For a *function* denoted by $f(x)$, the corresponding *equation* is $f(x) = 0$. Thus the expression $x^3 - 3x^2 - 4x + 11$ is a function, $x^3 - 3x^2 - 4x + 11 = 0$ is an equation.
- The equation $x^3 - x = 0$ has three *roots*, namely $x = -1$, $x = 0$ and $x = +1$. The *solution* of the equation is $x = -1, 0$ or $+1$. Solving an equation involves finding all its roots.

Trivial Equations

Students should avoid trivial equations both when solving them, and where demonstrating failure. For an equation to be non-trivial it must pass two tests.

- (i) It should be an equation they would expect to work on rather than just write down the solution (if it exists); for instance $\frac{1}{(x-a)} = 0$ is definitely not acceptable; nor is any polynomial expressed as a product of linear factors.
- (ii) Constructing a table of values for integer values of x should not, in effect, solve the equation. Thus $x^3 - 6x^2 + 11x - 6 = 0$ (roots at $x = 1, 2$ and 3) is not acceptable.

Oral Communication

Each student must talk about the task; this may take the form of a class presentation, an interview with the assessor or ongoing discussion with the assessor while the work is in progress. Topics for discussion may include strategies used to find suitable equations and explanations, with reference to graphical illustrations, of how the numerical methods work.

Use of Software

The use of existing computer or calculator software is encouraged, but students must:

- edit any print-outs and displays to include only what is relevant to the task in hand;
- demonstrate understanding of what the software has done, and how they could have performed the calculations themselves;
- appreciate that the use of such software allows them more time to spend on investigational work.

Selection of Equations

Centres may provide students with a list of at least ten equations from which they can, if they wish, select those they are going to solve or use to demonstrate failure of a method. Such a list of equations should be forwarded to the Moderator with the sample of coursework requested. A new set of equations must be supplied with each examination series. Centres may, however, exercise the right not to issue a list, on the grounds that candidates stand to benefit from the mathematics they learn while finding their own equations.

Methods for Advanced Mathematics (C3) Coursework: Assessment Sheet

Task: Candidates will investigate the solution of equations using the following three methods:

- Systematic search for change of sign using one of the three methods: decimal search, bisection or linear interpolation.
- Fixed point iteration using the Newton-Raphson method.
- Fixed point iteration after rearranging the equation $f(x) = 0$ into the form $x = g(x)$.

Coursework Title													
Candidate Name						Candidate Number							
Centre Number							Date						
Domain	Mark	Description						Comment	Mark				
Change of sign method (3)	1	The method is applied successfully to find one root of an equation.											
	1	Error bounds are stated and the method is illustrated graphically.											
	1	An example is given of an equation where one of the roots cannot be found by the chosen method. There is an illustrated explanation of why this is the case.											
Newton-Raphson method (5)	1	The method is applied successfully to find one root of a second equation.											
	1	All the roots of the equation are found.											
	1	The method is illustrated graphically for one root.											
	1	Error bounds are established for one of the roots.											
	1	An example is given of an equation where this method fails to find a particular root despite a starting value close to it. There is an illustrated explanation of why this has happened.											
Rearranging $f(x)=0$ in the form $x=g(x)$ (4)	1	A rearrangement is applied successfully to find a root of a third equation.											
	1	Convergence of this rearrangement to a root is demonstrated graphically and the magnitude of $g'(x)$ is discussed.											
	1	A rearrangement of the same equation is applied in a situation where the iteration fails to converge to the required root.											
	1	This failure is demonstrated graphically and the magnitude of $g'(x)$ is discussed.											
Comparison of methods (3)	1	One of the equations used above is selected and the other two methods are applied successfully to find the same root.											
	1	There is a sensible comparison of the relative merits of the three methods in terms of speed of convergence.											
	1	There is a sensible comparison of the relative merits of the three methods in terms of ease of use with available hardware and software.											
Written communication (1)	1	Correct notation and terminology are used.											
Oral communication (2)	2	Presentation		Please tick at least one box and give a brief report.									
		Interview											
		Discussion											
Half marks may be awarded but the overall total must be an integer. Please report overleaf on any help that the candidate has received beyond the guidelines								TOTAL	18				

Coursework must be available for moderation by OCR

6.4 APPLICATIONS OF ADVANCED MATHEMATICS, C4 (4754) A2

Objectives

To develop the work in *C1*, *C2* and *C3* in directions which allow it to be applied to real world problems.

Assessment

Examination

Paper A: (72 marks)
1 hour 30 minutes
The examination paper has two sections.

Section A: 5-7 questions, each worth at most 8 marks.
Section Total: 36 marks

Section B: two questions, each worth about 18 marks.
Section Total: 36 marks

Paper B: (18 marks)
1 hour

A comprehension task. (Further details on page 72.)
Total 18 marks

Assumed Knowledge

Candidates are expected to know the content for *C1*, *C2* and *C3*.

Subject Criteria

The Units *C1* and *C2* are required for Advanced Subsidiary GCE Mathematics in order to ensure coverage of the subject criteria.

The Units *C1*, *C2*, *C3* and *C4* are required for Advanced GCE Mathematics in order to ensure coverage of the subject criteria.

Calculators

In the MEI Structured Mathematics specification, no calculator is allowed in the examination for *C1*. For all other units, including this one, a graphical calculator is allowed.

APPLICATIONS OF ADVANCED MATHEMATICS, C4

Specification	Ref.	Competence Statements
---------------	------	-----------------------

ALGEBRA

The general binomial expansion.	C4a1	Be able to form the binomial expansion of $(1+x)^n$ where n is any rational number and find a particular term in it.
	2	Be able to write $(a+x)^n$ in the form $a^n \left(1 + \frac{x}{a}\right)^n$ prior to expansion.
Rational expressions.	3	Be able to simplify rational expressions.
Partial fractions.	4	Be able to solve equations involving algebraic fractions.
	5	Know how to express algebraic fractions as partial fractions.
	6	Know how to use partial fractions with the binomial expansion to find the power series for an algebraic fraction.

TRIGONOMETRY

sec, cosec and cot.	C4t1	Know the definitions of the sec, cosec and cot functions.
	2	Understand the relationship between the graphs of the sin, cos, tan, cosec, sec and cot functions.
	3	Know the relationships $\tan^2 \theta + 1 = \sec^2 \theta$ and $\cot^2 \theta + 1 = \operatorname{cosec}^2 \theta$.
Compound angle formulae.	4	Be able to use the identities for $\sin(\theta \pm \phi)$, $\cos(\theta \pm \phi)$, $\tan(\theta \pm \phi)$.
	5	Be able to use identities for $\sin 2\theta$, $\cos 2\theta$ (3 versions), $\tan 2\theta$.
Solution of trigonometrical equations.	6	Be able to solve simple trigonometrical equations within a given range including the use of any of the trigonometrical identities above.
	7	Know how to write the function $a \cos \theta \pm b \sin \theta$ in the forms $R \sin(\theta \pm \alpha)$ and $R \cos(\theta \pm \alpha)$ and how to use these to sketch the graph of the function, find its maximum and minimum values and to solve equations.

PARAMETRIC EQUATIONS

The use of parametric equations.	C4g1	Understand the meaning of the terms parameter and parametric equations.
	2	Be able to find the equivalent cartesian equation for parametric equations.
	3	Recognise the parametric form of a circle.
	4	Be able to find the gradient at a point on a curve defined in terms of a parameter by differentiation.

APPLICATIONS OF ADVANCED MATHEMATICS, C4

Ref.	Notes	Notation	Exclusions
------	-------	----------	------------

ALGEBRA

C4a1 For $|x| < 1$ when n is not a positive integer.

2 $\left|\frac{x}{a}\right| < 1$ when n is not a positive integer.

3 Including factorising, cancelling and algebraic division.

4

5 Proper fractions with the following denominators

$$(ax + b)(cx + d)$$

$$(ax + b)(cx + d)^2$$

$$(ax + b)(x^2 + c^2)$$

Improper fractions.

6

TRIGONOMETRY

C4t1 Including knowledge of the angles for which they are undefined.

2

3

4

5

6 Including identities from earlier units.
Knowledge of principal values.

7

PARAMETRIC EQUATIONS

C4g1

2

3

4

$$\frac{dy}{dx} = \frac{\left(\frac{dy}{dt}\right)}{\left(\frac{dx}{dt}\right)}$$

Stationary points.

Use to find the equations of tangents and normals to a curve.

APPLICATIONS OF ADVANCED MATHEMATICS, C4

Specification	Ref.	Competence Statements
---------------	------	-----------------------

CALCULUS

Numerical integration.	C4c1	Be able to use the trapezium rule to find an integral to a given level of accuracy.
Partial fractions.	2	Be able to use the method of partial fractions in integration.
Volumes of revolution.	3	Be able to calculate the volumes of the solids generated by rotating a plane region about the x -axis or the y -axis.
Differential equations.	4	Be able to formulate first order differential equations.
	5	Be able to solve first order differential equations.

VECTORS

Vectors in two and three dimensions.	C4v1	Understand the language of vectors in two and three dimensions.
	2	Be able to add vectors, multiply a vector by a scalar, and express a vector as a combination of others.
The scalar product.	3	Know how to calculate the scalar product of two vectors, and be able to use it to find the angle between two vectors.
Coordinate geometry in two and three dimensions.	4	Be able to find the distance between two points, the midpoint and other points of simple division of a line.
The equations of lines and planes.	5	Be able to form and use the equation of a line.
	6	Be able to form and use the equation of a plane.
The intersection of a line and a plane.	7	Know that a vector which is perpendicular to a plane is perpendicular to any line in the plane.
	8	Know that the angle between two planes is the same as the angle between their normals.
	9	Be able to find the intersection of a line and a plane.

COMPREHENSION

The ability to read and comprehend a mathematical argument or an example of the application of mathematics.	C4p1	Be able to follow mathematical arguments and descriptions of the solutions of problems when given in writing.
	2	Understand the modelling cycle and realise that it can be applied across many branches of mathematics.

APPLICATIONS OF ADVANCED MATHEMATICS, C4

Ref.	Notes	Notation	Exclusions
------	-------	----------	------------

CALCULUS

C4c1	Use of increasing numbers of strips to improve the accuracy. Use of increasing numbers of strips to estimate the error.		Questions requiring more than 3 applications of the trapezium rule.
2			
3			Axes of rotation other than the x - and y -axes.
4	From given information about rates of change.		
5	Differential equations with separable variables only.		

VECTORS

C4v1	Scalar, vector, modulus, magnitude, direction, position vector, unit vector, cartesian components, equal vectors, parallel vectors.	$\mathbf{i}, \mathbf{j}, \mathbf{k}, \hat{\mathbf{r}}$ $\begin{pmatrix} a_1 \\ a_2 \\ a_3 \end{pmatrix}$	
2	Geometrical interpretation.		
3	Including test for perpendicular vectors. The angle between two lines.	$\mathbf{a} \cdot \mathbf{b} = a_1b_1 + a_2b_2 + a_3b_3$ $= \mathbf{a} \mathbf{b} \cos \theta$	
4			
5	In vector and cartesian form.	Line: $\mathbf{r} = \mathbf{a} + t\mathbf{u}$ $\frac{x - a_1}{u_1} = \frac{y - a_2}{u_2} = \frac{z - a_3}{u_3} (= t)$.	
6	In vector and cartesian form.	Plane: $(\mathbf{r} - \mathbf{a}) \cdot \mathbf{n} = 0$ $n_1x + n_2y + n_3z + d = 0$ where $d = -\mathbf{a} \cdot \mathbf{n}$.	
7	If a vector is perpendicular to two non-parallel lines in a plane, it is perpendicular to the plane.		
8			
9			

COMPREHENSION

C4p1	This may be assessed using a real world modelling context.		
2	Abstraction from a real-world situation to a mathematical description; approximation simplification and solution; check against reality; progressive refinement.		

Applications of Advanced Mathematics (C4) Comprehension Task

Rationale

The aim of the comprehension task is to foster an appreciation among students that, in learning mathematics, they are acquiring skills which transcend the particular items of the specification content which have made up their course.

The objectives are that students should be able to:

- read and comprehend a mathematical argument or an example of the application of mathematics;
- respond to a synoptic piece of work covering ideas permeating their whole course;
- appreciate the relevance of particular techniques to real-world problems.

Description and Conduct

Paper B of *Applications of Advanced Mathematics (C4)* consists of a comprehension task on which candidates are expected to take no more than 40 minutes. The task takes the form of a written article followed by questions designed to test how well candidates have understood it. Care will be taken in preparing the task to ensure that the language is readily accessible.

Candidates are allowed to bring standard English dictionaries into the examination. Full regulations can be found in the JCQ booklet *Instructions for conducting examinations*, published annually.

The use of bi-lingual translation dictionaries by candidates for whom English is not their first language has to be applied for under the access arrangements rules. Full details can be found in the JCQ booklet *Access Arrangements, Reasonable Adjustments and Special Consideration*, published annually.

Content

By its nature, the content of the written piece of mathematics cannot be specified in the detail of the rest of the specification. However knowledge of GCSE and *C1*, *C2* and *C3* will be assumed, as well as the content of the rest of this unit. Candidates are expected to be aware of ideas concerning accuracy and errors. The written piece may follow a modelling cycle and in that case candidates will be expected to recognise it. No knowledge of mechanics will be assumed.

6.5 FURTHER CONCEPTS FOR ADVANCED MATHEMATICS, FP1 (4755) AS

Objectives

To develop an understanding of the rigour and technical accuracy needed for more advanced study of mathematics.

Assessment

Examination: (72 marks)
1 hour 30 minutes.
The examination paper has two sections.

Section A: 5-7 questions, each worth at most 8 marks.
Section Total: 36 marks.

Section B: three questions, each worth about 12 marks.
Section Total: 36 marks.

Assumed Knowledge

Candidates are expected to know the content for *C1* and *C2*.

Subject Criteria

This unit is required for Advanced Subsidiary Further Mathematics. Candidates proceeding to Advanced GCE Further Mathematics will also need *FP2*.

The Units *C1*, *C2*, *C3* and *C4* are required for Advanced GCE Mathematics in order to ensure coverage of the subject criteria.

Calculators

In the MEI Structured Mathematics specification, no calculator is allowed in the examination for *C1*. For all other units, including this one, a graphical calculator is allowed.

FURTHER CONCEPTS FOR ADVANCED MATHEMATICS, FP1

Specification	Ref.	Competence Statements
---------------	------	-----------------------

COMPLEX NUMBERS

Quadratic equations.	FP1j1	Be able to solve any quadratic equation with real coefficients.
Addition, subtraction, multiplication and division of complex numbers.	2	Understand the language of complex numbers.
	3	Be able to add, subtract, multiply and divide complex numbers given in the form: $x + yj$, where x and y are real.
	4	Know that a complex number is zero if and only if both the real and imaginary parts are zero.
Application of complex numbers to the solution of polynomial equations with real coefficients.	5	Know that the complex roots of real polynomial equations with real coefficients occur in conjugate pairs.
	6	Be able to solve equations of higher degree with real coefficients in simple cases.
	7	Know how to represent complex numbers and their conjugates on an Argand diagram.
Modulus-argument form	8	Be able to represent the sum and difference of two complex numbers on an Argand diagram.
	9	Be able to represent a complex number in modulus-argument form.
Simple loci in the Argand diagram.	10	Be able to represent simple sets of complex numbers as loci in the Argand diagram.

CURVE SKETCHING

Treatment and sketching of graphs of rational functions.	FP1C1	Be able to sketch the graph of $y = f(x)$ obtaining information about symmetry, asymptotes parallel to the axes, intercepts with the coordinate axes, behaviour near $x = 0$ and for numerically large x .
	2	Be able to ascertain the direction from which a curve approaches an asymptote.
	3	Be able to use a curve to solve an inequality.

FURTHER CONCEPTS FOR ADVANCED MATHEMATICS, FP1

Ref.	Notes	Notation	Exclusions
------	-------	----------	------------

COMPLEX NUMBERS

FP1j1		$j^2 = -1$	
2	Real part, imaginary part, complex conjugate, modulus, argument, real axis, imaginary axis.	$z = x + yj$ $z^* = x - yj$ $\text{Re}(z) = x$ $\text{Im}(z) = y$	
3	Division using complex conjugates.		
4			
5	e.g. to solve a cubic equation given one complex root.		Equations with degree > 4 . Equations with more than 2 complex roots (unless they are purely imaginary).
6			
7			
8			
9	Conversion between the forms $z = x + yj$ and $z = r(\cos \theta + \sin \theta j)$.	Modulus of $z: z $ Radian measure.	
10	Circles of the form $ z - a = r$. Half lines of the form $\arg(z - a) = \theta$.		

CURVE SKETCHING

FP1C1	Cases where $f(x) = \frac{g(x)}{h(x)}$ and the order of $g(x) \leq$ the order of $h(x)$.		Oblique asymptotes.
2	Vertical and horizontal asymptotes.		Formal treatment.
3			

FURTHER CONCEPTS FOR ADVANCED MATHEMATICS, FP1

Specification	Ref.	Competence Statements
---------------	------	-----------------------

PROOF

Meaning of the terms <i>if</i> , <i>only if</i> , <i>necessary</i> and <i>sufficient</i> .	FP1p1	Be able to use the terms <i>if</i> , <i>only if</i> , <i>necessary</i> and <i>sufficient</i> correctly in any appropriate context.
Identities.	2	Know the difference between an equation and an identity.
	3	Be able to find unknown constants in an identity.
Proof by induction.	4	Be able to construct and present a correct proof using mathematical induction.

ALGEBRA

Summation of simple finite series.	FP1a1	Know the difference between a sequence and a series.
	2	Be able to sum a simple series.
	3	Know the meaning of the word <i>converge</i> when applied to either a sequence or a series.
The manipulation of simple algebraic inequalities.	4	Be able to manipulate simple algebraic inequalities, to deduce the solution of such an inequality.
Relations between the roots and coefficients of quadratic, cubic and quartic equations.	5	Appreciate the relationship between the roots and coefficients of quadratic, cubic and quartic equations.
	6	Be able to form a new equation whose roots are related to the roots of a given equation by a linear transformation.

FURTHER CONCEPTS FOR ADVANCED MATHEMATICS, FP1

Ref.	Notes	Notation	Exclusions
------	-------	----------	------------

PROOF

FP1p1

- | | | | |
|---|--|---|-------------------------|
| 2 | An identity is true for all values of the variables, an equation for only certain values. | ≡ | |
| 3 | By substituting particular values for the variable. | | |
| 4 | Proofs of the sums of simple series.
The result to be proved will always be given explicitly. | | Proofs of divisibility. |

ALGEBRA

FP1a1

- | | | | |
|---|--|--|--|
| 2 | Using standard formulae for Σr , Σr^2 and Σr^3 .
Using the method of differences. | | Derivation of partial fractions. |
| 3 | | | |
| 4 | Including those expressible in the form $f(x) > 0$ where $f(x)$ can be expressed as a product of linear factors. | | Inequalities involving algebraic fractions where the numerator and denominator are of order ≥ 2 . |
| 5 | | Roots
$\alpha, \beta, \gamma, \delta$. | Equations of degree ≥ 5 . |
| 6 | | | New equations with non-linear combinations of roots. |

FURTHER CONCEPTS FOR ADVANCED MATHEMATICS, FP1

Specification	Ref.	Competence Statements
---------------	------	-----------------------

MATRICES

Matrix addition and multiplication.	FP1m1	Be able to add, subtract and multiply conformable matrices, and to multiply a matrix by a scalar.
	2	Know the zero and identity matrices, and what is meant by equal matrices.
	3	Know that matrix multiplication is associative but not commutative.
Linear transformations in a plane and their associated 2x2 matrices.	4	Be able to find the matrix associated with a linear transformation and vice-versa.
Combined transformations in a plane.	5	Understand successive transformations and the connection with matrix multiplication.
Invariance.	6	Understand the meaning of invariant points and lines of invariant points in a plane and how to find them.
Determinant of a matrix.	7	Be able to find the determinant of a 2x2 matrix.
	8	Know that the determinant gives the area scale factor of the transformation, and understand the significance of a zero determinant.
The meaning of the inverse of a square matrix.	9	Understand what is meant by an inverse matrix.
	10	Be able to find the inverse of a non-singular 2x2 matrix.
The product rule for inverses.	11	Appreciate the product rule for inverse matrices.
Solution of equations.	12	Know how to use matrices to solve linear equations.
	13	In the case of 2 linear equations in 2 unknowns, be able to give a geometrical interpretation of a case where the matrix is singular.

FURTHER CONCEPTS FOR ADVANCED MATHEMATICS, FP1

Ref.	Notes	Notation	Exclusions
MATRICES			
FP1m1	Matrices of any suitable order.	$\mathbf{M} = \begin{pmatrix} a & b \\ c & d \end{pmatrix}$	
2		\mathbf{O} (zero) \mathbf{I} (identity).	
3			
4	Reflection in the x and y axes and in the lines $y = \pm x$. Rotation centre the origin through an angle θ . Enlargement centre the origin.	Column vectors for the position of points.	
5			
6			
7		$\begin{vmatrix} a & b \\ c & d \end{vmatrix}$ or $\det \mathbf{M}$.	
8	The terms <i>singular</i> and <i>non-singular</i> .		
9	Square matrices of any order.	\mathbf{M}^{-1} (inverse).	
10	Candidates should know that: $\mathbf{AB} = k\mathbf{I} \Rightarrow \mathbf{A}^{-1} = \frac{1}{k}\mathbf{B}$.	The inverse of \mathbf{M} is $\frac{1}{\det \mathbf{M}} \begin{pmatrix} d & -b \\ -c & a \end{pmatrix}$	
11	$(\mathbf{AB})^{-1} = \mathbf{B}^{-1}\mathbf{A}^{-1}$.		
12			Equations with 3 or more unknowns when the inverse matrix is not known.
13	The graphs of the equations are parallel lines.		

6.6 FURTHER METHODS FOR ADVANCED MATHEMATICS, FP2 (4756) A2

Objectives

To build on and extend students' knowledge of Pure Mathematics and associated techniques.

Assessment

Examination: (72 marks)
1 hour 30 minutes.
The examination paper has two sections.

Section A: All questions are compulsory.
Three questions each worth about 18 marks.
One or two of the questions may be divided into independent parts on different topics in the specification.
Section Total: 54 marks.

Section B: One question worth 18 marks.
Section Total: 18 marks.

Assumed Knowledge

Candidates are expected to know the content for *C1*, *C2*, *C3*, *C4* and *FP1*.

Subject Criteria

Both this unit and *FP1* are required for Advanced GCE Further Mathematics.
The Units *C1*, *C2*, *C3* and *C4* are required for Advanced GCE Mathematics.

Calculators

In the MEI Structured Mathematics specification, no calculator is allowed in the examination for *C1*.
For all other units, including this one, a graphical calculator is allowed.

SECTION A – All topics in this section are to be studied.

FURTHER METHODS FOR ADVANCED MATHEMATICS, FP2

Specification	Ref.	Competence Statements
---------------	------	-----------------------

POLAR COORDINATES

Polar coordinates in two dimensions.	FP2P1	Understand the meaning of polar coordinates (r, θ) and be able to convert from polar to Cartesian coordinates and vice-versa.
--------------------------------------	-------	--

2 Be able to sketch curves with simple polar equations.

3 Be able to find the area enclosed by a polar curve.

CALCULUS

The inverse functions of sine, cosine and tangent.	FP2c1	Understand the definitions of inverse trigonometric functions.
--	-------	--

Differentiation of $\arcsin x$, $\arccos x$ and $\arctan x$.	2	Be able to differentiate inverse trigonometric functions.
--	---	---

Use of trigonometrical substitutions in integration.	3	Recognise integrals of functions of the form $(a^2 - x^2)^{-1/2}$ and $(a^2 + x^2)^{-1}$ and be able to integrate associated functions by using trigonometrical substitutions.
--	---	--

4 Use trigonometric identities to integrate functions.

SERIES

Maclaurin series. Approximate evaluation of a function.	FP2s1	Be able to find the Maclaurin series of a function, including the general term in simple cases.
---	-------	---

2 Appreciate that the series may converge only for a restricted set of values of x .

3 Identify and be able to use the Maclaurin series of standard functions.

FURTHER METHODS FOR ADVANCED MATHEMATICS, FP2

Ref.	Notes	Notation	Exclusions
------	-------	----------	------------

POLAR COORDINATES

FP2P1	Candidates will be expected to know the terms pole and initial line.	$r > 0$: continuous line. $r < 0$: broken line.
-------	--	--

2 e.g. $r = a(1 + \cos \theta)$, $r = a \cos 2\theta$.

3 Area = $\frac{1}{2} \int r^2 d\theta$.

CALCULUS

FP2c1	arcsin: $-\frac{\pi}{2} \leq \arcsin \leq \frac{\pi}{2}$. arccos: $0 \leq \arccos \leq \pi$. arctan: $-\frac{\pi}{2} \leq \arctan \leq \frac{\pi}{2}$.
-------	---

2

3

4 e.g. $\sin^2 x, \sin^3 x, \sin^4 x, \tan x$.

SERIES

FP2s1

2

3 Candidates will be expected to identify the series for e^x , $\ln(1+x)$, $\sin x$, $\cos x$ and $(1+x)^n$. The ranges of values for which these series are valid should be understood.

FURTHER METHODS FOR ADVANCED MATHEMATICS, FP2

Specification	Ref.	Competence Statements
---------------	------	-----------------------

COMPLEX NUMBERS

Modulus- argument form.	FP2j1	Understand the polar (modulus-argument) form of a complex number, and the definition of modulus, argument.
	2	Be able to multiply and divide complex number in polar form.
De Moivre's theorem and simple applications.	3	Understand de Moivre's theorem.
	4	Be able to apply de Moivre's theorem to finding multiple angle formulae and to summing suitable series.
Expression of complex numbers in the form $z = re^{j\theta}$.	5	Understand the definition $e^{j\theta} = \cos \theta + j\sin \theta$ and hence the form $z = re^{j\theta}$.
The n n^{th} roots of a complex number.	6	Know that every non-zero complex number has n n^{th} roots, and that in the Argand diagram these are the vertices of a regular n -gon.
	7	Know that the distinct n^{th} roots of $re^{j\theta}$ are: $r^{\frac{1}{n}} \left[\cos \left(\frac{\theta + 2k\pi}{n} \right) + j\sin \left(\frac{\theta + 2k\pi}{n} \right) \right]$ for $k = 0, 1, \dots, n - 1$.
	8	Be able to explain why the sum of all the n^{th} roots is zero.
Applications of complex numbers in Geometry.	9	Appreciate the effect in the Argand diagram of multiplication by a complex number.
	10	Be able to represent complex roots of unity on an Argand diagram.
	11	Be able to apply complex numbers to geometrical problems.

FURTHER METHODS FOR ADVANCED MATHEMATICS, FP2

Ref.	Notes	Notation	Exclusions
------	-------	----------	------------

COMPLEX NUMBERS

FP2j1	$z = r(\cos \theta + j \sin \theta)$ where $r = z $ and $\theta = \arg z$.	$ z $ for modulus, $\arg z$ for principal argument, $-\pi < \arg z \leq \pi$.	
2	$z_1 z_2 = r_1 r_2 [\cos(\theta_1 + \theta_2) + j \sin(\theta_1 + \theta_2)]$ $\frac{z_1}{z_2} = \frac{r_1}{r_2} [\cos(\theta_1 - \theta_2) + j \sin(\theta_1 - \theta_2)]$		
3			
4	e.g. the expression of $\tan 4\theta$ as a rational function of $\tan \theta$. e.g. finding $\sum_{r=0}^n \binom{n}{r} \cos r\theta$.		
5			
6			
7			
8			
9	Multiplication by $re^{j\theta}$ corresponds to enlargement with scale factor r with rotation through θ about the origin. e.g. multiplication by j corresponds to a rotation of $\frac{\pi}{2}$ about the origin.		
10			
11	e.g. relating to the geometry of regular polygons.		

FURTHER METHODS FOR ADVANCED MATHEMATICS, FP2

Specification	Ref.	Competence Statements
---------------	------	-----------------------

MATRICES

Determinant and inverse of a 3x3 matrix.	FP2m1	Be able to find the determinant of any 3x3 matrix and the inverse of a non-singular 3x3 matrix.
Eigenvalues and eigenvectors of 2x2 and 3x3 matrices.	2	Understand the meaning of eigenvalue and eigenvector, and be able to find these for 2x2 or 3x3 matrices whenever this is possible.
Diagonalisation and powers of 2x2 and 3x3 matrices	3	Be able to form the matrix of eigenvectors and use this to reduce a matrix to diagonal form.
	4	Be able to find powers of a 2x2 or 3x3 matrix.
Solution of equations.	5	Be able to solve a matrix equation or the equivalent simultaneous equations, and to interpret the solution geometrically.
The use of the Cayley-Hamilton Theorem.	6	Understand the term <i>characteristic equation</i> of a 2x2 or 3x3 matrix.
	7	Understand that every 2x2 or 3x3 matrix satisfies its own characteristic equation, and be able to use this.

FURTHER METHODS FOR ADVANCED MATHEMATICS, FP2

Ref.	Notes	Notation	Exclusions
------	-------	----------	------------

MATRICES

FP2m1

2			Repeated eigenvalues. Complex eigenvalues.
3			
4			
5			
6	$\det(\mathbf{M} - \lambda\mathbf{I}) = 0$.		Proof of the Cayley-Hamilton theorem. Knowledge of the Jordan form.
7	e.g. to find relations between the powers of a matrix. e.g. to find the inverse matrix.		

SECTION B The topic in this section is to be studied. Section B of the examination paper contains one mandatory question.

SECTION B

FURTHER METHODS FOR ADVANCED MATHEMATICS, FP2		
Specification	Ref.	Competence Statements

HYPERBOLIC FUNCTIONS		
----------------------	--	--

Hyperbolic functions: definitions, graphs, differentiation and integration.	FP2a4	Understand the definitions of hyperbolic functions and be able to sketch their graphs.
	5	Be able to differentiate and integrate hyperbolic functions.
Inverse hyperbolic functions, including the logarithmic forms. Use in integration.	6	Understand and be able to use the definitions of the inverse hyperbolic functions.
	7	Be able to use the logarithmic forms of the inverse hyperbolic functions.
	8	Be able to integrate $(x^2 + a^2)^{-1/2}$ and $(x^2 - a^2)^{-1/2}$ and related functions.

Option 2 (Investigation of Curves) has been removed from this specification

Option 2 (Investigation of Curves) has been removed from this specification

6.7 FURTHER APPLICATIONS OF ADVANCED MATHEMATICS, FP3 (4757) A2

Objectives

To give students an introduction to a number of more sophisticated areas of Pure Mathematics, with a choice of options.

Assessment

Examination: (72 marks)
1 hour 30 minutes.
Candidates answer three questions out of five, each worth 24 marks.

Assumed Knowledge

Candidates are expected to know the content for *C1*, *C2*, *C3*, *C4*, *FP1* and *FP2*.

Candidates attempting Option 5 are expected to be familiar with elementary concepts of probability and with expected values.

Subject Criteria

The Units *FP1* and *FP2* are required for Advanced GCE Further Mathematics.
The Units *C1*, *C2*, *C3* and *C4* are required for Advanced GCE Mathematics.

Calculators

In the MEI Structured Mathematics specification, no calculator is allowed in the examination for *C1*.
For all other units, including this one, a graphical calculator is allowed.

For Option 5, Markov chains, a calculator with the facility to handle matrices is required.

OPTION 1:

FURTHER APPLICATIONS OF ADVANCED MATHEMATICS, FP3

Specification	Ref.	Competence Statements
---------------	------	-----------------------

VECTORS

Vector (cross) product of two vectors.	FP3v1	Be able to form the vector product of two vectors in magnitude and direction, and in component form.
	2	Understand the anti-commutative and distributive properties of the vector product.
	3	Know the significance of $\mathbf{a} \times \mathbf{b} = \mathbf{0}$.
The intersection of two planes.	4	Be able to find the line of intersection of two planes.
The intersection of lines in three dimensions.	5	Be able to determine whether two lines in three dimensions are skew or intersect, and to find the point of intersection if there is one.
Distance of a point from a line or from a plane.	6	Be able to find the shortest distance from a point to a line in 2 or 3 dimensions.
	7	Be able to find the shortest distance from a point to a plane.
Scalar triple product.	8	Be able to find the scalar triple product of three vectors, and appreciate that its value is unchanged by cyclic permutation of the vectors.
Geometrical interpretation.	9	Be able to use the scalar triple product to determine the handedness of a set of vectors.
Volume of parallelepiped and tetrahedron.	10	Be able to use the scalar triple product to find the volume of a parallelepiped or tetrahedron.
Shortest distance between two skew lines.	11	Be able to use the scalar triple product to find the shortest distance between two skew lines.
Condition in three dimensions for two lines to intersect.	12	Be able to use the scalar triple product to determine whether or not two lines in 3 dimensions intersect.

FURTHER APPLICATIONS OF ADVANCED MATHEMATICS, FP3

Ref.	Notes	Notation	Exclusions
------	-------	----------	------------

VECTORS

FP3v1

$$\mathbf{a} \times \mathbf{b} = |\mathbf{a}| |\mathbf{b}| \sin \theta \hat{\mathbf{n}} = \begin{pmatrix} a_2 b_3 - a_3 b_2 \\ a_3 b_1 - a_1 b_3 \\ a_1 b_2 - a_2 b_1 \end{pmatrix}$$

2

3

4

5

6

7 Distance of point (α, β, γ) to plane:

$$n_1 x + n_2 y + n_3 z + d = 0 \text{ is } \frac{|\alpha n_1 + \beta n_2 + \gamma n_3 + d|}{\sqrt{n_1^2 + n_2^2 + n_3^2}}.$$

8 $\mathbf{a} \cdot (\mathbf{b} \times \mathbf{c}) = \det \mathbf{M}$ where \mathbf{M} is the 3×3 matrix $(\mathbf{a}, \mathbf{b}, \mathbf{c})$.

9

10

11 The shortest distance between the two skew lines:

$$\mathbf{r} = \mathbf{a} + \lambda \mathbf{d} \text{ and } \mathbf{r} = \mathbf{b} + \mu \mathbf{e} \text{ is } \left| (\mathbf{a} - \mathbf{b}) \cdot \frac{(\mathbf{d} \times \mathbf{e})}{|\mathbf{d} \times \mathbf{e}|} \right|.$$

12

OPTION 2:

FURTHER APPLICATIONS OF ADVANCED MATHEMATICS, FP3

Specification	Ref.	Competence Statements
---------------	------	-----------------------

MULTI-VARIABLE CALCULUS

$z = f(x, y)$ and its interpretation as a surface. Contour lines, and sections of the form $z = f(a, y)$ or $z = f(x, b)$.	FP3c1	Appreciate that the relation $z = f(x, y)$ defines a surface in three dimensions.
Sketching of surfaces.	2	Be able to sketch contours and sections, and know how these are related to the surface.
First order partial derivatives.	3	Be able to find first order partial derivatives.
Simple applications to surfaces and stationary points.	4	Be able to use the conditions $\frac{\partial z}{\partial x} = 0$ and $\frac{\partial z}{\partial y} = 0$ to find the coordinates of stationary points on a surface.
Surfaces in three dimensions defined by $g(x, y, z) = c$.	5	Appreciate that the relation $g(x, y, z) = c$ defines a surface in three dimensions.
	6	Be able to find grad g , and to evaluate this at a point on the surface to give a normal vector.
Applications to finding the normal line and the tangent plane at a point.	7	Be able to find the equations of the normal line and tangent plane at a point on the surface.
$\delta z \approx \frac{\partial z}{\partial x} \delta x + \frac{\partial z}{\partial y} \delta y$ and its application to errors	8	Appreciate that the tangent plane gives a local approximation to the surface, and hence that $\delta z \approx \frac{\partial z}{\partial x} \delta x + \frac{\partial z}{\partial y} \delta y$, and be able to use this, or the similar result for functions of more than two variables, to estimate the consequence of errors in these variables.

OPTION 3:

FURTHER APPLICATIONS OF ADVANCED MATHEMATICS, FP3

Specification	Ref.	Competence Statements
---------------	------	-----------------------

DIFFERENTIAL GEOMETRY

Arc length.	FP3g1	Be able to calculate arc length using cartesian, parametric and polar coordinates.
Curved surface area and volume of a solid of revolution.	2	Be able to calculate the volume and curved surface area of a solid of revolution using cartesian or parametric co-ordinates.
Envelopes.	3	Be able to find the envelope of a family of curves by eliminating p between $f(x, y, p) = 0$ and $\frac{\partial f}{\partial p}(x, y, p) = 0$.
Intrinsic coordinates and intrinsic equations.	4	Understand the use of arc length and inclination of tangent as intrinsic coordinates.
	5	Be able to work with intrinsic equations in simple cases.
Curvature, radius of curvature.	6	Be able to use the definitions of curvature and radius of curvature.
Centre of curvature.	7	Be able to find the centre of curvature.
Evolute.	8	Be able to find the evolute as the locus of the centre of curvature and as the envelope of the normals.

FURTHER APPLICATIONS OF ADVANCED MATHEMATICS, FP3

Ref.	Notes	Notation	Exclusions
------	-------	----------	------------

DIFFERENTIAL GEOMETRY

FP3g1

2 Rotation about x - or y -axis only.

3

4

$$s, \psi$$

Unit vectors

$$\hat{\mathbf{t}} = \begin{bmatrix} \cos \psi \\ \sin \psi \end{bmatrix}$$

$$\hat{\mathbf{n}} = \begin{bmatrix} -\sin \psi \\ \cos \psi \end{bmatrix}$$

5 e.g. $s = c \tan \psi$ (catenary).
 e.g. $s = 4a \sin \psi$ (cycloid).

6

$$\kappa = \frac{d\psi}{ds}, \quad \rho = \frac{ds}{d\psi}$$

ρ, κ

The cartesian and parametric forms are also required.

7

$$\mathbf{c} = \mathbf{r} + \rho \hat{\mathbf{n}}$$

8

OPTION 4:

FURTHER APPLICATIONS OF ADVANCED MATHEMATICS, FP3

Specification	Ref.	Competence Statements
---------------	------	-----------------------

GROUPS

The axioms of a group.	FP3a1	Understand the group axioms and the associated language.
Illustrations of groups.	2	Be familiar with examples of groups, and of the use of group tables.
Cyclic groups.	3	Understand the meaning of the term cyclic group, and how a single element can generate such a group.
The order of a finite group; the order of an element of a group.	4	Understand the terms order of a finite group, order of an element.
Subgroups.	5	Understand the term subgroup.
Lagrange's theorem.	6	Understand and be able to use Lagrange's theorem.
Isomorphism.	7	Understand that different situations can give rise to essentially the same structure.
	8	Be able to specify an isomorphism in simple cases.

FURTHER APPLICATIONS OF ADVANCED MATHEMATICS, FP3

Ref.	Notes	Notation	Exclusions
GROUPS			
FP3a1	The terms binary operation, closed, associative, identity, inverse, abelian.		
2	e.g. symmetries of geometrical figures, residue classes, permutations, matrices.		
3			
4			
5			
6	In a finite group, the order of a subgroup divides the order of the group. The corollary that the order of an element divides the order of the group.		Proof of Lagrange's theorem.
7	Concept and illustrations only.		
8	e.g. be able to decide whether two groups of order 4 or 6 are isomorphic.		

OPTION 5:

FURTHER APPLICATIONS OF ADVANCED MATHEMATICS, FP3

Specification	Ref.	Competence Statements
---------------	------	-----------------------

MARKOV CHAINS

The assessment of this option will be based on the assumption that candidates have a calculator with the ability to handle matrices.

Candidates who do not have such a calculator are advised not to attempt this option.

Transition matrix.	FP3m1	Understand the relationships between random processes, Markov chain models and transition matrices.
	2	Be able to represent a suitable process by means of a matrix of transition probabilities.
	3	Be able to interpret a given transition matrix in terms of an underlying process.
Limit properties of a non-periodic transition matrix.	4	Be able to use a transition matrix to calculate probabilities of future events.
	5	Know that successive powers of a non-periodic transition matrix tend towards a limit.
	6	Be able to calculate equilibrium probabilities.
Run lengths; expected values.	7	Be able to calculate the expected run length of a particular event.
Periodic states.	8	Be able to work with processes having periodic states.
Absorption and reflection.	9	Be able to work with processes having absorbing states.
	10	Be able to work with processes having reflecting barriers.

FURTHER APPLICATIONS OF ADVANCED MATHEMATICS, FP3

Ref.	Notes	Notation	Exclusions
------	-------	----------	------------

MARKOV CHAINS

FP3m1

2		P	
3			
4			
5			
6			
7			
8			
9			
10			

6.8 DIFFERENTIAL EQUATIONS, DE (4758) A2

Objectives

To extend the work in *Applications of Advanced Mathematics (C4)* on the formulation and solution of differential equations. Students are expected to have a reasonable degree of manipulative competence and to be able to handle more complicated problems.

Assessment

Examination (72 marks)
1 hour 30 minutes
Candidates answer three questions from four, each worth 24 marks.

Coursework (18 marks)
One modelling assignment involving the use of differential equations at an appropriate level of sophistication.
There are no restrictions on the context chosen.

Unless otherwise specified the value of the acceleration due to gravity should be taken to be exactly 9.8 ms^{-2} .

Assumed Knowledge

Candidates are expected to know the content of *C1*, *C2*, *C3* and *C4*.
In addition candidates are expected to know basic kinematics and Newton's Second Law.
Relevant knowledge of complex numbers will also be required.

Calculators

In the MEI Structured Mathematics specification, no calculator is allowed in the examination for *C1*.
For all other units, including this one, a graphical calculator is allowed.

DIFFERENTIAL EQUATIONS, DE		
Specification	Ref.	Competence Statements

MODELLING WITH DIFFERENTIAL EQUATIONS		
---------------------------------------	--	--

Constructions of models.	DEp1	Understand how to introduce and define variables to describe a given situation in mathematical terms.
	2	Be able to relate 1 st and 2 nd order derivatives to verbal descriptions and so formulate differential equations.
	3	Know the language of kinematics, and the relationships between the various terms.
	4	Know Newton's 2 nd law of motion.
	5	Understand how to determine the order of a differential equation.
Interpretation of solutions.	6	Be able to interpret the solution of a differential equation in terms of the original situation.
	7	Appreciate the difference between a general solution and a particular solution, i.e. one which satisfies particular prescribed conditions.
	8	Understand the significance of the number of arbitrary constants in a general solution.
Tangent fields.	9	Be able to investigate the effect of changing a differential equation on its solution.
	10	Be able to sketch the tangent field for a 1 st order differential equation and be able to interpret it.
	11	Be able to sketch and interpret the curve of the solution corresponding to particular conditions.
	12	Be able to identify isoclines and use them in sketching and interpreting tangent fields.

FIRST ORDER DIFFERENTIAL EQUATIONS		
------------------------------------	--	--

Equations with separable variables.	DEc1	Be able to find both general and particular solutions of a 1 st order differential equation with separable variables.
First order linear differential equations.	2	Be able to solve 1 st order linear differential equations with constant coefficients.
	3	Be able to distinguish differential equations where the integrating factor method is appropriate, and to rearrange such equations if necessary.
	4	Be able to find an integrating factor and understand its significance in the solution of an equation.
	5	Be able to solve an equation using an integrating factor and find both general and particular solutions.

DIFFERENTIAL EQUATIONS, DE			
Ref.	Notes	Notation	Exclusions

MODELLING WITH DIFFERENTIAL EQUATIONS			
---------------------------------------	--	--	--

DEp1	Candidates will be expected to model real-life situations with differential equations.	The rate of change of x with respect to time $= \dot{x}$ (etc.)	
2	The differential equations will not be restricted to those which candidates can solve analytically.		
3	Including acceleration $= v \frac{dv}{ds}$.	$v = \frac{ds}{dt}$ $a = \frac{dv}{dt} = \frac{d^2s}{dt^2}$	
4	In the form $F = ma$.		Variable mass.
5			
6			
7			
8			
9			
10	e.g. changing the values of coefficients.		
11		The term direction field has the same meaning as tangent field.	
12	e.g. the solution through a particular point.		

FIRST ORDER DIFFERENTIAL EQUATIONS			
------------------------------------	--	--	--

DEc1			
2	Equations of the form $y' + ay = 0$ and $y' + ay = f(x)$ in simple cases, where a is constant.		
3	Equations which can be expressed in the form: $\frac{dy}{dx} + P(x)y = Q(x)$.		
4	Integrating factor $e^{\int P dx}$.		
5	e.g. through a particular point.		

DIFFERENTIAL EQUATIONS, DE		
Specification	Ref.	Competence Statements

SECOND AND HIGHER ORDER DIFFERENTIAL EQUATIONS		
--	--	--

Homogeneous second order linear differential equations.	DEc6	Be able to solve homogenous 2 nd order differential equations, using the auxiliary equation and complementary function.
	7	Appreciate the relationship between different cases of the solution and the nature of the roots of the auxiliary equation, and be able to interpret these different cases graphically.
	8	Be able to find the particular solution in given contexts.
The general second order linear differential equation.	9	Be able to solve the general 2 nd order linear differential equation, by solving the homogeneous case and adding a particular integral.
	10	Be able to find particular integrals in simple cases. Appreciate the relationship between different cases of the solution and the nature of the roots of the auxiliary equation, and be able to interpret these different cases graphically.
	11	Be able to solve the equation for simple harmonic motion, $\ddot{x} + \omega(x + k) = 0$, and be able to relate the various forms of the solution to each other.
Damped oscillations.	12	Be able to model damped oscillations using 2 nd order linear differential equations, and understand the associated terminology.
	13	Be able to interpret the solutions of equations modelling damped oscillations in words and graphically.
Higher order linear differential equations.	14	Appreciate that the same methods can be extended to higher order equations and be able to do so in simple cases.

SIMULTANEOUS DIFFERENTIAL EQUATIONS		
-------------------------------------	--	--

Simultaneous linear differential equations.	DEe1	Model situations with one independent variable and two dependent variables which lead to 1st order simultaneous differential equations, and know how to solve these by eliminating one variable to produce a single, 2 nd order equation.
	2	Appreciate that the same method can be extended to more than two such equations, leading by elimination to a single higher order equation.

NUMERICAL METHODS		
-------------------	--	--

Step by step methods.	DEs1	Be able to use step by step methods (e.g. Euler's method) to solve 1 st order differential equations (including simultaneous equations) where appropriate.
-----------------------	------	---

DIFFERENTIAL EQUATIONS, DE			
Ref.	Notes	Notation	Exclusions

SECOND AND HIGHER ORDER DIFFERENTIAL EQUATIONS

DEc6	Equations of the form $y'' + ay' + by = 0$ where a and b are constants.		
7	Discriminant $> 0, = 0, < 0$. A basic understanding of the complex roots of a quadratic equation is assumed.		
8			
9	Equations of the form $y'' + ay' + by = f(x)$ where a and b are constants.		
10	Cases where $f(x)$ is a polynomial, trigonometric or exponential function.		
11			
12			
13	The damping will be described as 'over-', 'critical' or 'under-' according to whether the roots of the auxiliary equation are real distinct, equal or complex.		
14	Adequate guidance will be given in examination questions.		

SIMULTANEOUS DIFFERENTIAL EQUATIONS
--

DEe1	Applications such as predator-prey models.		
2	Adequate guidance will be given in any examination question involving more than two dependent variables.		

NUMERICAL METHODS

DEs1	Adequate guidance will be given in examination questions.	Specific step-by-step algorithms.
------	---	-----------------------------------

Differential Equations (DE) Coursework: How Differential Equations are used to Solve Real-World Problems

Rationale

The aims of the coursework are that students should learn how differential equations are used to solve real-world problems and that they should appreciate how the theory they have learnt for the examination helps them to do this.

The objectives are that they should be able to undertake the various steps in the problem solving procedure shown in the flow chart in Section 5.2. The assessment criteria are closely related to these steps.

Description

There are two aspects to the work.

- (i) The modelling cycle consists of pen and paper development of the consequences of the basic assumptions made, leading to a predicted outcome which must then be tested against reality.
- (ii) In the experimental cycle, results are collected in order to give insight into the situation under investigation, so that a realistic model can be developed.

Level of Work

The task represents 20% of the assessment and the work involved should be consistent with that figure, both in quantity and level of sophistication. Tasks which allow only superficial or trivial treatment should be avoided.

Assessment

Each task must be assessed on one of the coursework assessment sheets, A or B. The assessor decides on the appropriate sheet according to the way the candidate has approached the particular task.

- (A) In this case the modelling cycle is investigated in some depth, whilst the check against reality may use the data from published sources, from experiments which the candidate has not actually performed or from experience; there must however be a quantitative element in such data.
- (B) The work presented is approximately evenly divided between developing the model, and one or more experiments conducted by the candidate to verify the quality of predictions from it and/or to inform its development.

No other mark sheet may be used, nor may these be amended in any way.

One mark is available for each criterion statement. Half marks may be awarded, but the overall total must be rounded (up or down) to an integer.

Note that in the case of Mark Scheme A, the marks for ‘Manipulating the Model’ may be awarded for the quality of the work either on the first or the second modelling cycles.

Task Selection

Centres are encouraged to develop their own coursework tasks. If they have any doubt about the suitability of a proposed task, they are recommended to submit details of it to the Principal Coursework Moderator, via OCR.

However, Centres which are new to the scheme are strongly recommended to use the tasks published by MEI while they are familiarising themselves with the nature of coursework. They should ensure that the material they have is that published for this specification and not that for an earlier specification.

Centres are advised that the choice of suitable tasks is crucial to the success of their candidates’ coursework.

Differential Equations (DE) Coursework: Assessment Sheet A (Mark Scheme A) Work Based on the Modelling Cycle

Task: Candidates will model a real-life situation of their own choice which requires the use of differential equations.

Coursework Title												
Candidate Name						Candidate Number						
Centre Number						Date						
Domain	Mark	Description						Comment	Mark			
Simplifying the situation and setting up the model.	1	There are clear statements of the assumptions made and an awareness is shown of the relative importance of these assumptions.										
	1	The relevance of the assumptions to the initial equations of the model is explained clearly.										
	1	Differential equation(s) to model the situation are established and justified.										
Manipulating the model.	1	A correct method of solution is applied to the differential equation(s).										
	1	A solution to the differential equation(s) is obtained.										
	1	Values for the parameters of the equation(s) are chosen and justified.										
	1	There is a quantitative consideration of the effects of possible variation in the values of the parameters.										
The collection of data to verify the model.	1	The source and means of collecting the data are clearly described and their relevance to the model is demonstrated.										
	1	The data are presented in a form suitable for comparison with the predictions of the model.										
Comparison between the data collected and the predictions of the model.	1	A clear comparison is made, using diagrams and graphs where appropriate.										
	1	The effects of variation in the parameters are taken into account.										
Revision of the model.	1	In the light of the comparison, proposals are made for amending the initial assumptions to improve the quality of the model.										
	1	New equations are established as a result of the amended assumptions.										
Assessment of the improvement obtained.	1	The new equations are manipulated to produce new predictions.										
	1	A comparison is made between the data and the new predictions, and comments made on whether an improvement has been obtained.										
Oral communication	2	Presentation		Please tick at least one box and give a brief report								
		Interview										
		Discussion										
Half marks may be awarded but the overall total must be an integer. Please report overleaf on any help that the candidate has received beyond the guidelines							TOTAL	18				

Coursework must be available for moderation by OCR

6.9 MECHANICS 1, M1 (4761) AS

Objectives

To introduce students to mathematical modelling and to the basic concepts in kinematics, statics and dynamics which underlie the study of mechanics.

Students will be expected to formulate models, using the mechanics within the specification, and to show an appreciation of any assumptions made; they will also be expected to make simple deductions from the model and to comment on its usefulness. They will understand the particle model.

The examination will test candidates' knowledge of principles without excessive emphasis on algebraic or calculus skills.

Assessment

Examination (72 marks)

1 hour 30 minutes

The examination paper has two sections:

Section A: 5 - 7 questions, each worth at most 8 marks.
Section Total: 36 marks

Section B: two questions, each worth about 18 marks.
Section Total: 36 marks

In the written papers, unless otherwise specified the value of the acceleration due to gravity should be taken to be exactly 9.8 ms^{-2} .

Assumed Knowledge

Candidates are expected to know the content of *C1* and *C2*.

Calculators

In the MEI Structured Mathematics specification, no calculator is allowed in the examination for *C1*. For all other units, including this one, a graphical calculator is allowed.

MECHANICS 1, M1		
Specification	Ref.	Competence Statements

MODELLING

This section is fundamental to all the mechanics specifications

The modelling cycle applied to real-world problems.	M1p1	Understand the concept of a mathematical model.
	2	Be able to abstract from a real world situation to a mathematical description (model).
	3	Know the language used to describe simplifying assumptions.
	4	Understand the particle model.
	5	Be able to analyse the model appropriately.
	6	Be able to interpret and communicate the implications of the analysis in terms of the situation being modelled.
	7	Appreciate the importance of a check against reality.
	8	Appreciate that a model may need to be progressively refined.
S.I. Units.	9	Know the relevant S.I. units.

VECTORS

The properties of vectors and techniques associated with them in 2 or 3 dimensions.	M1v1	Understand the language of vectors.
	2	Be able to find the magnitude and direction of a vector given in component form.
	3	Be able to express a vector in component form given its magnitude and direction.
	4	Be able to carry out elementary operations on vectors.
	5	Be able to apply vectors to mechanics problems.

MECHANICS 1, M1			
Ref.	Notes	Notation	Exclusions

MODELLING

This section is fundamental to all the mechanics specifications

M1p1	Flow chart on page 35.		
2			
3	The words: light; smooth; uniform; particle; inextensible; thin; rigid.		
4			
5	Manipulation of the mathematical model.		
6	The implications in real world terms. The need for estimation of accuracy.		
7	A modelling exercise which is not in some way checked against reality is of little or no value.		
8			
9	Metre (m), kilogram (kg), second (s), metre/second (ms^{-1}), metre/second/second (ms^{-2}), newton (N).		

VECTORS

M1v1	Vector, scalar, unit vector, position vector, component, magnitude, direction, resultant.	Vectors printed in bold . Unit vectors i, j, k . The magnitude of the vector a is written a or a . Position vector \overline{OP} or r .	
2		Column vector e.g. $\begin{pmatrix} 2 \\ 3 \\ -1 \end{pmatrix}$	The direction of a vector in 3 dimensions.
3			
4	Addition, subtraction, multiplication by a scalar carried out algebraically and geometrically.		Product of two vectors.
5	Problems involving motion and forces.		

MECHANICS 1, M1		
Specification	Ref.	Competence Statements

KINEMATICS		
-------------------	--	--

Motion in 1 dimension.	M1k1	Understand the language of kinematics.
The accurate use of terminology.	2	Know the difference between position, displacement and distance.
	3	Know the difference between velocity and speed, and between acceleration and magnitude of acceleration.
Kinematics graphs.	4	Be able to draw and interpret kinematics graphs, knowing the significance (where appropriate) of their gradients and the areas underneath them.
The use of calculus in kinematics.	5	Be able to differentiate position and velocity with respect to time and know what measures result.
	6	Be able to integrate acceleration and velocity with respect to time and know what measures result.
The use of constant acceleration formulae.	7	Be able to recognise when the use of constant acceleration formulae is appropriate.
	8	Be able to solve kinematics problems using constant acceleration formulae and calculus.
Motion in 2 and 3 dimensions.	9	Understand the language of kinematics appropriate to motion in 2 and 3 dimensions.
	10	Be able to extend the scope of techniques from motion in 1 to that in 2 and 3 dimensions by using vectors.
	11	Be able to find the Cartesian equation of the path of a particle when the components of its position vector are given in terms of time.
	12	Be able to use vectors to solve problems in kinematics.

MECHANICS 1, M1			
Ref.	Notes	Notation	Exclusions

KINEMATICS			
------------	--	--	--

M1k1	Position, displacement, distance; speed, velocity; acceleration, magnitude of acceleration; relative velocity (in 1 dimension).		
2			
3			
4	Position-time, distance-time, velocity-time, speed-time, acceleration-time.		
5			Cases where the time dependency is not of polynomial form will not be tested in this module.
6			
7			
8			
9	Position vector; relative position.		
10	The use of calculus and the use of constant acceleration formulae.	$\mathbf{a} = \dot{\mathbf{v}} = \frac{d\mathbf{v}}{dt}, \mathbf{v} = \dot{\mathbf{r}} = \frac{d\mathbf{r}}{dt}$ $\mathbf{r} = \int \mathbf{v} dt, \mathbf{v} = \int \mathbf{a} dt,$ $\mathbf{s} = \mathbf{u}t + \frac{1}{2}\mathbf{a}t^2,$ $\mathbf{v} = \mathbf{u} + \mathbf{a}t,$ $\mathbf{s} = \frac{1}{2}(\mathbf{u} + \mathbf{v})t.$	Vector form of $v^2 - u^2 = 2as$.
11	At least one of the components will be a linear function of time.		Cases involving motion in 3 dimensions.
12			

MECHANICS 1, M1		
Specification	Ref.	Competence Statements

FORCE		
--------------	--	--

The identification of the forces acting on a body and their representation in a diagram.	M1d1	Understand the language relating to forces.
	2	Be able to identify the forces acting on a system and represent them in a force diagram.
Vector treatment of forces.	3	Be able to resolve a force into components and be able to select suitable directions for resolution.
	4	Be able to find the resultant of several concurrent forces by vector addition.
	5	Know that a body is in equilibrium under a set of concurrent forces if and only if their resultant is zero.
	6	Know that vectors representing forces in equilibrium form a closed polygon.
	7	Be able to formulate and solve equations for equilibrium by resolving forces in suitable directions, or by way of a polygon of forces.

NEWTON'S LAWS OF MOTION		
--------------------------------	--	--

The application of Newton's laws of motion to a particle.	M1n1	Know and understand the meaning of Newton's three laws.
	2	Understand the term equation of motion.
	3	Be able to formulate the equation of motion for a particle in 1-dimensional motion.
	4	Be able to formulate the equation of motion for a particle in 2- and 3- dimensional motion.
	5	Be able to formulate and solve separate equations of motion for connected particles.

PROJECTILES		
--------------------	--	--

The motion of a projectile.	M1y1	Be able to formulate the equations of motion of a projectile.
	2	Know how to find the position and velocity at any time of a projectile, including the maximum height and range.
	3	Be able to find the initial velocity of a projectile given sufficient information.
	4	Be able to eliminate time from the component equations that give the horizontal and vertical displacement in terms of time.
	5	Be able to solve problems involving projectiles.

MECHANICS 1, M1			
Ref.	Notes	Notation	Exclusions

FORCE			
-------	--	--	--

M1d1	Weight, tension, thrust, normal reaction (or normal contact force), frictional force, resistance.		Calculations involving coefficient of friction.
2			
3	e.g. horizontally and vertically or parallel and perpendicular to an inclined plane.		
4	Graphically or by adding components.		
5			
6			
7	Lami's Theorem may be used where appropriate.		

NEWTON'S LAWS OF MOTION			
-------------------------	--	--	--

M1n1		$\mathbf{F} = m\mathbf{a}$.	Variable mass.
2			
3	Including motion under gravity.		
4			
5	e.g. simple pulley systems, trains.		

PROJECTILES			
-------------	--	--	--

M1y1			Air resistance. Inclined plane.
2			Recall of formulae.
3			
4			
5			

6.10 MECHANICS 2, M2 (4762) A2

Objectives

To build on the work in *Mechanics 1* by extending the range of mechanics concepts which students are able to use in modelling situations. Students will be able to use the rigid body model in simple cases involving moments.

Students will be expected to formulate models, using the mechanics within this specification and that for *Mechanics 1*, and to show an appreciation of any assumptions made; they will also be expected to make simple deductions from the model and to comment on its usefulness.

The examination will test candidates' knowledge of principles and of when they should be applied. The examination will avoid excessive emphasis on algebraic or calculus skills, but candidates will be expected to interpret simple algebraic expressions.

Assessment

Examination (72 marks)
1 hour 30 minutes
There will be four questions each worth about 18 marks.

In the written papers, unless otherwise specified the value of the acceleration due to gravity should be taken to be exactly 9.8 ms^{-2} .

Assumed Knowledge

Candidates are expected to know the content of *C1* and *C2* and *M1*.

Calculators

In the MEI Structured Mathematics specification, no calculator is allowed in the examination for *C1*. For all other units, including this one, a graphical calculator is allowed.

MECHANICS 2, M2		
Specification	Ref.	Competence Statements

FORCE		
-------	--	--

Frictional force.	M2d1	Understand that bodies in contact may be subject to a frictional force as well as a normal contact force (normal reaction), and be able to draw an appropriate force diagram.
	2	Understand that the total contact force between surfaces may be expressed in terms of a frictional force and a normal contact force (normal reaction).
	3	Understand that the frictional force may be modelled by $F \leq \mu R$
	4	Be able to apply Newton's Laws to problems involving friction.
Rigid bodies in equilibrium subject to forces in two dimensions.	5	Be able to draw a force diagram for a rigid body.
	6	Understand that a system of forces can have a turning effect on a rigid body.
	7	Be able to calculate the moment about a fixed axis of a force acting on a body.
	8	Understand and be able to apply the conditions for equilibrium of a rigid body to the solution of problems.
	9	Be able to identify whether equilibrium will be broken by sliding or toppling in simple cases.
Light frameworks.	10	Be able to find the internal forces in a framework of light, pin-jointed rods by applying the conditions for equilibrium at the pin-joints.
	11	Be able to determine which rods in a framework are in compression and which in tension.

WORK, ENERGY AND POWER		
------------------------	--	--

Concepts of work and energy.	M2w1	Be able to calculate the work done, both by a force which moves along its line of action and by a force which moves at an angle to its line of action.
	2	Be able to calculate kinetic energy.
	3	Understand the term mechanical energy.
The work-energy principle.	4	Understand the work-energy principle.
	5	Understand the terms conservative and dissipative forces.
	6	Be able to calculate gravitational potential energy.
	7	Be able to solve problems using the principle of conservation of energy.
Power.	8	Understand that the power of a force is the rate at which it does work.
	9	Be able to apply the concept of power to the solution of problems.

MECHANICS 2, M2

Ref.	Notes	Notation	Exclusions
------	-------	----------	------------

FORCE

M2d1	Smooth is used to mean frictionless.		
2			
3	Limiting friction.		The term angle of friction.
4			
5	In cases where the particle model is not appropriate.		
6	e.g. simple levers.		
7	Both as the product of force and perpendicular distance of the axis from the line of action of the force and by first resolving the force into components.		Vector treatment.
8	The resultant of all the applied forces is zero and the sum of their moments about any axis is zero. Three forces in equilibrium must be concurrent.		
9	e.g. a cube on an inclined plane.		
10			
11	The term thrust may be used to describe a compression force.		Bow's notation.

WORK, ENERGY AND POWER

M2w1			Continuously variable forces. F.s
2		$\frac{1}{2}mv^2$	
3			
4	The total work done by all the external forces acting on a body is equal to the increase in the kinetic energy of the body.		
5			
6	Relative to some arbitrary zero level.	mgh	
7	e.g. the maximum height of some projectile, a particle sliding down a curved surface, a child swinging on a rope.		
8	Power is Force x Speed in the direction of the Force. The concept of average power.		
9	e.g. finding the maximum speed of a vehicle.		

MECHANICS 2, M2

Specification	Ref.	Competence Statements
---------------	------	-----------------------

MOMENTUM AND IMPULSE

Momentum and impulse treated as vectors.	M2i1	Be able to calculate the impulse of a force as a vector.
	2	Understand the concept of momentum and appreciate that it is a vector quantity.
	3	Understand and be able to apply the Impulse-Momentum equation to problems.
Conservation of linear momentum.	4	Understand that a system subject to no external force conserves its momentum.
	5	Be able to derive the conservation of momentum equation for a collision between two particles in one dimension.
	6	Be able to apply the principle of conservation of momentum to direct impacts within a system of bodies.
Coefficient of restitution.	7	Understand Newton's Experimental Law and the meaning of coefficient of restitution, and be able to apply it in modelling impacts.
	8	Be able to solve problems using both momentum conservation and Newton's Experimental Law.
	9	Understand that mechanical energy is not conserved during impacts (unless $e = 1$) and be able to find the loss of mechanical energy.
Oblique impact with a smooth plane.	10	Understand that in an oblique impact between an object and a smooth plane, the impulse acts in a direction normal to the plane.
	11	Know that the velocity of the object parallel to the plane is unchanged by impact.
	12	Know that the direction of the component of the velocity perpendicular to plane is reversed and that its magnitude is multiplied by the coefficient of restitution.
	13	Be able to calculate the loss of kinetic energy in an oblique impact.
	14	Be able to solve problems involving oblique impact.

CENTRE OF MASS

Centre of a mass of a set of point masses.	M2G1	Be able to find the centre of mass of a system of particles of given position and mass.
Centre of mass of simple shapes.	2	Appreciate how to locate centre of mass by appeal to symmetry.
Centre of mass of composite bodies.	3	Be able to find the centre of a mass of a composite body by considering each constituent part as a particle at its centre of mass.
Applications of the centre of mass.	4	Be able to use the position of the centre of mass in problems involving the equilibrium of a rigid body.

MECHANICS 2, M2			
Ref.	Notes	Notation	Exclusions

MOMENTUM AND IMPULSE			
----------------------	--	--	--

M2i1	Impulse = Force x Time.		The use of calculus for variable forces.
2			
3	The total impulse of all the forces acting on a body is equal to the change in momentum of the body. Problems may involve an understanding of relative velocity in one dimension.		
4			
5			
6	e.g. colliding railway trucks.		
7	e.g. between two spheres, or between a sphere and a wall.	e for coefficient of restitution.	
8			
9			
10			
11			
12			
13			
14	e.g. a ball bouncing following a projectile motion.		

CENTRE OF MASS			
----------------	--	--	--

M2G1	In 1, 2 and 3 dimensions.	$(\bar{x}, \bar{y}, \bar{z})$ $\left(\sum_i m_i\right)\bar{x} = \sum_i m_i x_i$	Calculus methods. Non-uniform bodies.
2	Rod, rectangular lamina, circular lamina, cuboid, sphere.		
3	Composite bodies may be formed by the addition or subtraction of parts. Where a composite body includes parts whose centre of mass the candidate is not expected to know (e.g. triangle, semicircle, cone), the centre of mass will be given.		
4	e.g. a suspended object or an object standing on an inclined plane.		

6.11 MECHANICS 3, M3 (4763) A2

Objectives

To build on the work in *Mechanics 1* and *Mechanics 2*, further extending the range of mechanics concepts which students are able to use in modelling situations.

The examination questions will be designed to test candidates' understanding of the principles involved and of when they should be applied, rather than a high degree of manipulative skill, but candidates will be expected to interpret simple expressions written in algebra and the language of calculus.

Assessment

Examination (72 marks)
1 hour 30 minutes
There will be four questions each worth about 18 marks.

In the written papers, unless otherwise specified the value of the acceleration due to gravity should be taken to be exactly 9.8 ms^{-2} .

Assumed Knowledge

Candidates are expected to know the content of *C1*, *C2*, *C3* and *C4* and *M1* and *M2*.

Calculators

In the MEI Structured Mathematics specification, no calculator is allowed in the examination for *C1*. For all other units, including this one, a graphical calculator is allowed.

MECHANICS 3, M3		
Specification	Ref.	Competence Statements

DIMENSIONAL ANALYSIS		
-----------------------------	--	--

Dimensional consistency.	M3q1	Be able to find the dimensions of a quantity in terms of M, L, T.
	2	Understand that some quantities are dimensionless.
	3	Be able to determine the units of a quantity by reference to its dimensions.
	4	Be able to change the units in which a quantity is given.
	5	Be able to use dimensional analysis as an error check.
Formulating models using dimensional arguments.	6	Use dimensional analysis to determine unknown indices in a proposed formula.

CIRCULAR MOTION		
------------------------	--	--

The language of circular motion.	M3r1	Understand the language associated with circular motion.
Modelling circular motion.	2	Identify the force(s) acting on a body in circular motion.
	3	Be able to calculate acceleration towards the centre of circular motion.
Circular motion with uniform speed.	4	Be able to solve problems involving circular motion with uniform speed.
Circular motion with non-uniform speed.	5	Be able to solve problems involving circular motion with non-uniform speed.
	6	Be able to calculate tangential acceleration.
	7	Be able to solve problems involving motion in a vertical circle.
	8	Identify the conditions under which a particle departs from circular motion.

MECHANICS 3, M3			
Ref.	Notes	Notation	Exclusions

DIMENSIONAL ANALYSIS			
----------------------	--	--	--

M3q1	e.g. density, energy, momentum.	M, L, T, []	
2			
3			
4	e.g. density from kgm^{-3} to gcm^{-3} .		
5			
6	e.g. for the period of a pendulum.		

CIRCULAR MOTION			
-----------------	--	--	--

M3r1	The terms tangential, radial and angular speed, radial component of acceleration, tangential component of acceleration.	$\dot{\theta}$, ω for angular speed.	
2	Candidates will be expected to set up equations of motion in simple cases.	$v = r\dot{\theta}$ or $r\omega$.	
3	Using the expressions $\frac{v^2}{r}$ and $r\dot{\theta}^2$.		
4	e.g. a conical pendulum, a car travelling horizontally on a cambered circular track.		
5			
6	Tangential component of acceleration = $r\ddot{\theta}$. Use of Newton's 2 nd law in tangential direction.		
7	The use of conservation of energy, and of $F = ma$ in the radial direction.		
8	e.g. when a string becomes slack, when a particle leaves a surface.		

MECHANICS 3, M3		
Specification	Ref.	Competence Statements

HOOKE'S LAW		
-------------	--	--

Extension of an elastic string and extension or compression of a spring.	M3h1	Be able to calculate the stiffness or modulus of elasticity in a given situation.
	2	Be able to calculate the tension in an elastic string or spring.
	3	Be able to calculate the equilibrium position of a system involving elastic strings or springs.
	4	Be able to calculate energy stored in a string or spring.
	5	Be able to use energy principles to determine extreme positions.

SIMPLE HARMONIC MOTION		
------------------------	--	--

The Simple Harmonic Motion equation and its solution.	M3o1	Recognise situations which may be modelled by SHM.
	2	Be able to recognise the standard form of the equation of motion of SHM and formulate it as appropriate.
	3	Be able to recognise the SHM equation expressed in non-standard forms and to transform it into the standard form by means of substitution.
	4	Recognise the solution of the SHM equation in the form $x = a \sin(\omega t + \varepsilon)$ and be able to interpret it.
	5	Recognise other forms of the solution of the SHM equation, and be able to relate the various forms to each other.
	6	Be able to select a form of the solution of the SHM equation appropriate to the initial conditions.
	7	Be able to verify solutions of the SHM equation using calculus.
	8	Be able to apply standard results for SHM in context.
Applications of Simple Harmonic Motion.	9	Be able to analyse motion under the action of springs or strings as examples of SHM.
	10	Be able to calculate suitable constants to model given data by SHM equations.

MECHANICS 3, M3			
Ref.	Notes	Notation	Exclusions

HOOKE'S LAW			
-------------	--	--	--

M3h1		$T = kx$ where k is the stiffness.	
2		Tension = $\frac{\lambda x}{l_0}$ where λ is the modulus of elasticity and l_0 the natural length.	
3	e.g. a weight suspended by a spring.		
4		$\frac{1}{2} \frac{\lambda x^2}{l_0}$ or $\frac{1}{2} kx^2$	
5	Application to maximum extension for given starting conditions in a system, whether horizontal or vertical.		

SIMPLE HARMONIC MOTION			
------------------------	--	--	--

M3o1	Including approximate cases such as a pendulum.		
2	The form $\ddot{x} = -\omega^2 x$		
3	e.g. $\ddot{x} + cx = 0, \ddot{x} = -\omega^2 (x + k)$ x can represent variables such as angles and population size.		
4	The significance of the constants a, ω and ε should be understood.	$a =$ amplitude, $T =$ period = $\frac{2\pi}{\omega}$ $\varepsilon =$ phase	Damped oscillations. Solution of the SHM equation other than by verification.
5	$x = a \cos(\omega t + \varepsilon), x = A \sin \omega t + B \cos \omega t$	$a = \sqrt{(A^2 + B^2)}$	
6			
7	Differentiation of sine and cosine.		
8	e.g. $v^2 = \omega^2 (a^2 - x^2), T = \frac{2\pi}{\omega}$		
9			
10			

MECHANICS 3, M3		
Specification	Ref.	Competence Statements

SOLID BODIES AND PLANE LAMINAE		
--------------------------------	--	--

Centre of Mass.	M3g1	* Be able to calculate the volume generated by rotating a plane region about an axis.
	2	Be able to use calculus methods to calculate the centre of mass of solid bodies formed by rotating a plane area about an axis.
	3	Be able to find the centre of mass of a compound body, parts of which are solids of revolution.
	4	Be able to use calculus methods to calculate the centres of mass of plane laminae.
	5	Apply knowledge of centres of mass to simple cases of equilibrium.

* This topic also appears in C4. It is included here for completeness.

MECHANICS 3, M3			
Ref.	Notes	Notation	Exclusions

SOLID BODIES AND PLANE LAMINAE			
---------------------------------------	--	--	--

M3g1	Rotation about the x - and y -axes only.		The use of non-cartesian coordinates.
2	e.g. hemisphere, cone.		Variable density.
3	By treatment as equivalent to a finite system of particles.		Pappus' theorems.
4			
5	Including composite bodies.		

6.12 MECHANICS 4, M4 (4764) A2

Objectives

To prepare students for more advanced courses at university by extending the use of calculus in mechanics.

Students will be expected to be technically competent in the use of calculus and to be able to apply it to a variety of situations.

Students are expected to apply the modelling principles detailed in *Mechanics 1* in the context of this module.

Assessment

Examination (72 marks)
1 hour 30 minutes
The examination paper has two sections.

Section A: two compulsory questions, each worth about 12 marks.
Section Total: 24 marks

Section B: two compulsory questions, each worth about 24 marks.
Section Total: 48 marks

Unless otherwise specified the value of the acceleration due to gravity should be taken to be exactly 9.8 ms^{-2} .

Assumed Knowledge

Candidates are expected to know the content of *C1*, *C2*, *C3*, *C4*, *FP1* and *FP2* and *M1*, *M2* and *M3*.

Calculators

In the MEI Structured Mathematics specification, no calculator is allowed in the examination for *C1*. For all other units, including this one, a graphical calculator is allowed.

MECHANICS 4, M4		
Specification	Ref.	Competence Statements

VARIABLE FORCES		
-----------------	--	--

Application of variable forces in 1 dimension.	M4d1	Be able to calculate measures involving variable forces, in given dynamic situations in 1 dimension.
	2	Be able to formulate and solve differential equations using an appropriate expression for acceleration.

VARIABLE MASS		
---------------	--	--

The application of Newton's Second Law to problems involving variable mass.	M4k1	Understand and apply Newton's 2nd Law in the form $F = \frac{d}{dt}(mv)$.
	2	Be able to set up and solve differential equations for situations involving variable mass.

STABILITY		
-----------	--	--

The stability of equilibrium of a system of particles where the position of each is determined by a single parameter.	M4d3	Know and apply the energy criteria for the stability of a system of particles.
	4	Appreciate that potential energy must be related to some fixed origin.

MECHANICS 4, M4			
Ref.	Notes	Notation	Exclusions

VARIABLE FORCES

M4d1	Work, energy, power, impulse.	$\text{work} = \int F ds .$ $\text{energy} = \int P dt .$ impulse $= \int F dt .$ $\text{power} = Fv .$	
2	e.g. for the velocity of a particle falling in a resistive medium.	$a = \frac{dv}{dt} = \frac{d^2 s}{dt^2}$ $a = v \frac{dv}{ds}$	

VARIABLE MASS

M4k1			
2	e.g. the terminal speed of a raindrop falling through a mist. e.g. the motion of a rocket.		

STABILITY

M4d3	Use of gravitational or elastic potential energy.		
4			

MECHANICS 4, M4

Specification	Ref.	Competence Statements
----------------------	-------------	------------------------------

ROTATION OF A RIGID BODY

Calculation of moment of inertia.	M4r1	Understand the concept of moment of inertia as the analogue of mass in rotational motion.
Rotation of a rigid body about a fixed axis.	2	Be able to calculate moments of inertia of simple plane shapes and solids of uniform density from first principles.
	3	Know and use the perpendicular and parallel axes theorems.
	4	Be able to calculate centres of mass and moments of inertia of bodies of variable density and of compound bodies.
The equation of motion.	5	Be able to formulate the equation of motion of a rigid body about a fixed axis.
Kinetic energy of rotation.	6	Be able to apply the principle of conservation of energy to rotational motion of a rigid body.
	7	Be able to determine the period of small oscillations of a compound pendulum.
Angular momentum.	8	Be able to calculate the angular momentum of a rigid body and understand its significance.
Conservation of angular momentum.	9	Understand the conditions under which angular momentum is conserved, and apply the principle of conservation of angular momentum.
Motion following an impulsive blow.	10	Know how to calculate the angular velocity of a rotating body immediately after an impulsive blow.

MECHANICS 4, M4			
Ref.	Notes	Notation	Exclusions

ROTATION OF A RIGID BODY			
--------------------------	--	--	--

M4r1		$I = \sum mr^2$	
2			
3			
4			
5		$L = I\dot{\theta}$	
6		$KE = \frac{1}{2}I\dot{\theta}^2$	
7		Angular momentum = $I\dot{\theta}$	
8	e.g. a bullet striking a rigid body suspended from a fixed axis e.g. a ring threaded on a smooth rotating rod.		
9			
10			

6.13 STATISTICS 1, S1 (4766) AS

Objectives

To enable students to build on and extend the data handling and sampling techniques they have learnt at GCSE.

To enable students to apply theoretical knowledge to practical situations using simple probability models.

To give students insight into the ideas and techniques underlying hypothesis testing.

Assessment

Examination (72 marks)
1 hour 30 minutes
The examination paper has two sections:

Section A: 5 - 7 questions, each worth at most 8 marks.
Section Total: 36 marks

Section B: two questions, each worth about 18 marks.
Section Total: 36 marks

Assumed Knowledge

Candidates are expected to know the content for Intermediate Tier GCSE*. In addition, they need to know the binomial expansion as covered in *CI*.

*See note on page 34.

Calculators

In the MEI Structured Mathematics specification, no calculator is allowed in the examination for *CI*. For all other units, including this one, a graphical calculator is allowed.

The use of an asterisk * in a competence statement indicates assumed knowledge. These items will not be the focus of examination questions and are included for clarity and completeness. However, they may be used within questions on more advanced statistics.

STATISTICS 1, S1		
Specification	Ref.	Competence Statements

PROCESSES

*This section is fundamental to all the statistics units in this specification (Statistics 1-4).
In this unit, the ideas may be used in examination questions but will not be their main subject.*

Statistical modelling.	S1p1	Be able to abstract from a real world situation to a statistical description (model).
	2	Be able to apply an appropriate analysis to a statistical model.
	3	Be able to interpret and communicate results.
	4	Appreciate that a model may need to be progressively refined.
Sampling.	5	* Understand the meanings of the terms population and sample.
	6	* Be aware of the concept of random sampling.

DATA PRESENTATION

Classification and visual presentation of data.	S1D1	* Know how to classify data as categorical, discrete or continuous.
	2	* Understand the meaning of and be able to construct frequency tables for ungrouped data and grouped data.
	3	* Know how to display categorical data using a pie chart or a bar chart.
	4	Know how to display discrete data using a vertical line chart.
	5	Know how to display continuous data using a histogram for both unequal and equal class intervals.
	6	* Know how to display and interpret data on a stem and leaf diagram.
	7	* Know how to display and interpret data on a box and whisker plot.
	8	Know how to display and interpret a cumulative frequency distribution.
	9	Know how to classify frequency distributions showing skewness.

STATISTICS 1, S1

Ref.	Notes	Notation	Exclusions
------	-------	----------	------------

PROCESSES

*This section is fundamental to all the statistics units in this specification (Statistics 1-4).
In this unit, the ideas may be used in examination questions but will not be their main subject.*

S1p1	Approximation and simplification involving appropriate distributions and probability models.		Formal definitions.
2			
3	Their implications in real-world terms.		
4	Check against reality.		
5			
6			

DATA PRESENTATION

S1D1			
2	Define class intervals and class boundaries.		
3			
4			
5	Area proportional to frequency. Use of the term frequency density will be expected.		
6	The term stemplot is also widely used. Stem and leaf diagrams will be expected to be sorted.		
7	The term boxplot is also widely used. The term outlier can be applied to data which are at least $1.5 \times \text{IQR}$ beyond the nearer quartile.		
8			
9	Positive and negative skewness.		Measures of skewness.

STATISTICS 1, S1		
Specification	Ref.	Competence Statements

DATA PRESENTATION (continued)		
-------------------------------	--	--

Measures of central tendency and dispersion.	10	Know how to find median*, mean*, mode* and midrange.
	11	Know the usefulness of each of the above measures of central tendency.
	12	Know how to find range*, percentiles, quartiles* and interquartile range*.
	13	Know how to calculate and interpret mean squared deviation, root mean squared deviation, variance and standard deviation.
	14	Be able to use the statistical functions of a calculator to find mean, root mean square deviation and standard deviation.
	15	Know how the mean and standard deviation are affected by linear coding.
	16	Understand the term outlier.

STATISTICS 1, S1			
Ref.	Notes	Notation	Exclusions
DATA PRESENTATION			
10	For raw data, frequency distributions, grouped frequency distributions.	Mean = \bar{x}	
11			
12			
13	For raw data, frequency distributions, grouped frequency distributions. The term outlier can be applied to data which are at least 2 standard deviations from the mean.	$msd = \frac{S_{xx}}{n} = \frac{1}{n} \sum_{i=1}^n (x_i - \bar{x})^2$, $rmsd = \sqrt{msd}$. Sample variance: $s^2 = \frac{S_{xx}}{n-1} = \frac{1}{(n-1)} \sum_{i=1}^n (x_i - \bar{x})^2$. (†) Sample standard deviation: $s = \sqrt{\text{variance}}$. (§)	Corrections for class interval in these calculations.
14			
15	$y_i = a + bx_i \Rightarrow \bar{y} = a + b\bar{x}$, $s_y^2 = b^2 s_x^2$		Proof of equivalence will not be tested.
16	The term outlier can be applied to data which are: (a) at least 2 standard deviations from the mean; (b) at least $1.5 \times \text{IQR}$ beyond the nearer quartile.		

DATA PRESENTATION	
Notation for sample variance and sample standard deviation	
<p>The notations s^2 and s for sample variance and sample standard deviation, respectively, are written into both British Standards (BS3534-1, 1993) and International Standards (ISO 3534).</p> <p>The definitions are those given above in equations (†) and (§). The calculations are carried out using divisor $(n-1)$.</p> <p>In this specification, the usage will be consistent with these definitions. Thus the meanings of ‘sample variance’, denoted by s^2, and ‘sample standard deviation’, denoted by s, are uniquely defined, as calculated with divisor $(n-1)$.</p>	<p>In early work in statistics it is common practice to introduce these concepts with divisor n rather than $(n-1)$. However there is no recognised notation to denote the quantities so derived.</p> <p>In this specification, in order to ensure unambiguity of meaning, these quantities will be referred to by the functional names of ‘mean square deviation’ and ‘root mean square deviation’. The letters <i>msd</i> and <i>rmsd</i> will be used to denote their values.</p> <p>Students should be aware of the variations in notation used by manufacturers on calculators and know what the symbols on their particular models represent.</p>

STATISTICS 1, S1		
Specification	Ref.	Competence Statements

PROBABILITY		
-------------	--	--

Probability of events in a finite sample space.	S1u1	Know how to calculate the probability of one event.
	2	Understand the concept of a complementary event and know that the probability of an event may be found by finding that of its complementary event.
Probability of two or more events which are:	3	Know how to draw sample space diagrams to help calculate probabilities.
	4	Know how to calculate the expected frequency of an event given its probability.
(i) mutually exclusive;	5	Understand the concepts of mutually exclusive events and independent events.
	6	Know to add probabilities for mutually exclusive events.
	7	Know to multiply probabilities for independent events.
(ii) not mutually exclusive.	8	Know how to use tree diagrams to assist in the calculation of probabilities.
	9	Know how to calculate probabilities for two events which are not mutually exclusive.
Conditional probability.	10	Be able to use Venn diagrams to help calculations of probabilities for up to three events.
	11	Know how to calculate conditional probabilities by formula, from tree diagrams or sample space diagrams
	12	Know that $P(B A) = P(B) \Leftrightarrow B$ and A are independent.

DISCRETE RANDOM VARIABLES		
---------------------------	--	--

Probability distributions.	S1R1	Be able to use probability functions, given algebraically or in tables.
Calculation of probability, expectation (mean) and variance.	2	Be able to calculate the numerical probabilities for a simple distribution.
	3	Be able to calculate the expectation (mean), $E(X)$, in simple cases and understand its meaning.
	4	Be able to calculate the variance, $\text{Var}(X)$, in simple cases.

STATISTICS 1, S1			
Ref.	Notes	Notation	Exclusions

PROBABILITY			
-------------	--	--	--

S1u1			
2		$P(A)$ A' is the event 'Not A '	
3			
4		Expected frequency: $n P(A)$	
5			Formal notation and definitions.
6	To find $P(A \text{ or } B)$.		
7	To find $P(A \text{ and } B)$ Including the use of complementary events. e.g. finding the probability of at least one 6 in five throws of a die.		
8			
9			
10	Candidates should understand, though not necessarily in this form, the relation: $P(A \cup B) = P(A) + P(B) - P(A \cap B)$.		Probability of a general or infinite number of events. Formal proofs.
11	$P(A \cap B) = P(A).P(B A)$	$P(B A)$	
12	In this case $P(A \cap B) = P(A).P(B)$.		

DISCRETE RANDOM VARIABLES			
---------------------------	--	--	--

S1R1	In <i>SI</i> questions will only be set on simple finite distributions.		
2		$P(X = x)$	
3		$E(X) = \mu$	
4	Knowledge of $\text{Var}(X) = E(X^2) - \mu^2$.	$\text{Var}(X) = E[(X - \mu)^2]$	

STATISTICS 1, S1

Specification	Ref.	Competence Statements
---------------	------	-----------------------

THE BINOMIAL DISTRIBUTION AND ITS USE IN HYPOTHESIS TESTING

Situations leading to a binomial distribution.	S1H1	Recognise situations which give rise to a binomial distribution.
	2	Be able to identify the binomial parameter p , the probability of success.
Calculations relating to binomial distribution.	3	Be able to calculate probabilities using the binomial distribution.
	4	Know that nC_r is the number of ways of selecting r objects from n .
	5	Know that $n!$ is the number of ways of arranging n objects in line.
Knowledge of mean.	6	Understand and apply mean = np .
Calculation of expected frequencies.	7	Be able to calculate the expected frequencies of the various possible outcomes from a series of binomial trials.
Hypothesis testing for a binomial probability p .	8	Understand the process of hypothesis testing and the associated vocabulary.
	9	Be able to identify Null and Alternative Hypotheses (H_0 and H_1) when setting up a hypothesis test on a binomial probability model.
	10	Be able to conduct hypothesis tests at various levels of significance.
	11	Be able to identify the critical and acceptance regions.
	12	Be able to draw a correct conclusion from the results of a hypothesis test on a binomial probability model.
	13	Understand when to apply 1- tail and 2- tail tests.

STATISTICS 1, S1			
Ref.	Notes	Notation	Exclusions

THE BINOMIAL DISTRIBUTION AND ITS USE IN HYPOTHESIS TESTING
--

S1H1

2	As a model for observed data.	$B(n, p), q = 1 - p$ ~ means 'has the distribution'.	
3	Including use of tables of cumulative binomial probabilities.		
4		${}^n C_r = \binom{n}{r} = \frac{n!}{(n-r)!r!}$	
5			
6			Formal proof of variance of the binomial distribution.
7			
8	Null hypothesis, alternative hypothesis. Significance level, 1-tail test, 2-tail test. Critical value, critical region, acceptance region.		
9		H_0, H_1	
10			Normal approximation.
11			
12			
13			

6.14 STATISTICS 2, S2 (4767) A2

Objectives

To extend students' ability to represent data in bivariate situations, with an emphasis on linear and rank order modelling, and associated hypothesis testing.

To introduce continuous probability distributions through the Normal distribution.

Assessment

Examination (72 marks)
1 hour 30 minutes
There will be four questions each worth about 18 marks.

Assumed Knowledge

Candidates are expected to know the content of *CI* and *SI*. Candidates also need to know the series expansion of e^x .

Calculators

In the MEI Structured Mathematics specification, no calculator is allowed in the examination for *CI*. For all other units, including this one, a graphical calculator is allowed.

STATISTICS 2, S2

Specification	Ref.	Competence Statements
---------------	------	-----------------------

BIVARIATE DATA

Scatter diagram.	S2b1	Know how to draw a scatter diagram.
	2	Know the difference between dependent and independent variables.
Pearson's product moment correlation coefficient (pmcc).	3	Know how to calculate the pmcc from raw data or summary statistics.
	4	Know how to carry out hypothesis tests using the pmcc and tables of critical values.
Spearman's Rank correlation coefficient.	5	Know how to calculate Spearman's rank correlation coefficient from raw data or summary statistics.
	6	Know how to carry out hypothesis tests using Spearman's rank correlation coefficient and tables of critical values.
Regression line for a random variable on a non-random variable.	7	Know how to calculate the equation of the least squares regression line using raw data or summary statistics.
	8	Know the meaning of the term residual and be able to calculate and interpret residuals.

POISSON DISTRIBUTION

Situations leading to a Poisson distribution.	S2P1	Know the situations under which the Poisson distribution is likely to be an appropriate model.
Calculations of probability and of expected frequencies.	2	Be able to calculate the probabilities within a Poisson distribution.
	3	Be able to use the Poisson distribution as an approximation to the binomial distribution, and know when to do so.
The mean and variance of the Poisson distribution.	4	Know the mean and variance of a Poisson distribution.
The sum of independent Poisson distributions.	5	Know that the sum of two or more independent Poisson distributions is also a Poisson distribution.

STATISTICS 2, S2			
Ref.	Notes	Notation	Exclusions

BIVARIATE DATA			
----------------	--	--	--

S2b1			
2			
3		Sample value r .	
4	Only 'H ₀ : No correlation' will be tested. Hypothesis tests using Pearson's product moment correlation coefficient require a modelling assumption that the data are drawn from a bivariate Normal distribution. This may be recognised on a scatter diagram by an approximately elliptical distribution of points. Candidates will not be required to know the formal meaning of bivariate Normality but will be expected to know that both variables must be random and that where one or both of the distributions is skewed, bimodal, etc., the procedure is likely to be inaccurate. They will also be expected to recognise (from a scatter diagram) cases of non-linear association and, where appropriate, to apply a test based on Spearman's correlation coefficient.		
5		Sample value r_s .	
6	Only 'H ₀ : No association' will be tested. Hypothesis tests using Spearman's rank correlation coefficient require no modelling assumption about the underlying distribution.		
7	The goodness of fit of a regression line may be judged by looking at the scatter diagram. Examination questions will be confined to cases in which a random variable, Y , and a non-random variable, x , are modelled by a relationship in which the expected value of Y is a linear function of x .		Derivation of the least squares regression line.
8	Informal checking of a model by looking at residuals.		

POISSON DISTRIBUTION			
----------------------	--	--	--

S2P1		$X \sim \text{Poisson}(\lambda)$	
2	Including use of tables of cumulative Poisson probabilities.		
3			
4			Formal proof.
5	$X \sim \text{Poisson}(\lambda)$ and $Y \sim \text{Poisson}(\mu)$ $\Rightarrow X + Y \sim \text{Poisson}(\lambda + \mu)$ when X and Y are independent.		Formal proofs.

STATISTICS 2, S2		
Specification	Ref.	Competence Statements

CONTINGENCY TABLES		
--------------------	--	--

The χ^2 test.	S2H1	Be able to apply the χ^2 test to a contingency table.
--------------------	------	--

	2	Be able to interpret the results of a χ^2 test.
--	---	--

NORMAL DISTRIBUTION		
---------------------	--	--

The use of the Normal distribution.	S2N1	Be able to use the Normal distribution as a model.
	2	Be able to standardise a Normal variable and use the Normal distribution tables.

The use of the Normal distribution as an approximation to the binomial and Poisson distributions.	3	Be able to use the Normal distribution as an approximation to the binomial distribution and know when it is appropriate to do so.
	4	Be able to use the Normal distribution as an approximation to the Poisson distribution and know when it is appropriate to do so.
	5	Know when to use a continuity correction and be able to do so.

Hypothesis test for a single mean.	6	Be able to carry out a hypothesis test for a single mean using the Normal distribution and know when it is appropriate to do so.
------------------------------------	---	--

STATISTICS 2, S2			
Ref.	Notes	Notation	Exclusions

CONTINGENCY TABLES			
--------------------	--	--	--

S2H1	The use of Yates' continuity correction for 2×2 contingency tables will not be required in examination questions. Candidates who use it appropriately will, however, be eligible for full marks.		
2	This may involve considering the individual cells in the contingency table.		

NORMAL DISTRIBUTION			
---------------------	--	--	--

S2N1			
2		$X \sim N(\mu, \sigma^2)$	Proof.
3	Variance of $B(n, p)$ is npq $B(n, p) \approx N(np, npq)$		Proof.
4	Poisson (λ) $\approx N(\lambda, \lambda)$		
5			
6	In situations where either (a) the population variance is known or (b) the population variance is unknown but the sample size is large $E(\bar{X}) = \mu, \text{Var}(\bar{X}) = \frac{\sigma^2}{n}$.		

6.15 STATISTICS 3, S3 (4768) A2

Objectives

To introduce students to more advanced statistical ideas, based on the foundation provided by *S1* and *S2*, particularly involving continuous random variables and inference.

Assessment

Examination (72 marks)
1 hour 30 minutes
There will be four questions each worth about 18 marks.

Assumed Knowledge

Candidates are expected to know the content for *C1*, *C2*, *C3* and *C4* and for *S1* and *S2*. In addition they may be required to evaluate integrals of the type $\int_a^{\infty} f(x)dx$.

Calculators

In the MEI Structured Mathematics specification, no calculator is allowed in the examination for *C1*. For all other units, including this one, a graphical calculator is allowed.

STATISTICS 3, S3

Specification	Ref.	Competence Statements
---------------	------	-----------------------

CONTINUOUS RANDOM VARIABLES

The probability density function (pdf) of a continuous random variable.	S3R1	Be able to use a simple continuous random variable as a model.
	2	Understand the meaning of a pdf and be able to use one to find probabilities.
	3	Know the properties of a pdf.
	4	Find the mean and variance from a given pdf.
	5	Find the mode and median from a given pdf.
The cumulative distribution function (cdf) and its relationship to the probability density function.	6	Understand the meaning of a cdf and know how to obtain one from a given pdf.
	7	Know how to obtain a pdf from a given cdf.
	8	Use a cdf to calculate the median and other percentiles.

EXPECTATION ALGEBRA

Calculation of probability, expectation (mean) and variance of random variables.	S3a1	Be able to use the result $E(a + bX) = a + bE(X)$.
	2	Be able to use the result $\text{Var}(a + bX) = b^2 \text{Var}(X)$.
Linear combinations of two (or more) independent random variables.	3	Know how to find the mean and variance of any linear combination of independent random variables.
The distribution of a linear combination of independent Normal variables.	4	Be able to use linear combinations of Normal random variables in solving problems.

STATISTICS 3, S3			
Ref.	Notes	Notation	Exclusions

CONTINUOUS RANDOM VARIABLES

S3R1			
2	Concepts rather than expertise at calculus will be examined.	$f(x)$	pdfs comprising more than two (non-zero) parts.
3			
4			
5			
6		$F(x)$	
7	$f(x) = F'(x)$		
8			

EXPECTATION ALGEBRA

S3a1			
2			
3	$E(X \pm Y) = E(X) \pm E(Y)$ $\text{Var}(X \pm Y) = \text{Var}(X) + \text{Var}(Y)$ $E(aX \pm bY) = aE(X) \pm bE(Y)$ $\text{Var}(aX \pm bY) = a^2 \text{Var}(X) + b^2 \text{Var}(Y)$		Proofs.
4	A linear combination of independent normal variables so also normal.		

STATISTICS 3, S3

Specification	Ref.	Competence Statements
---------------	------	-----------------------

INFERENCE

Sampling methods.	S3I1	Know the definition of the term simple random sample.
	2	Understand the use of different sampling methods.
Estimation of population mean and variance from a simple random sample.	3	Be able to estimate population mean from sample data.
	4	Be able to estimate population variance using the sample variance, s^2 .
Distribution of the mean of a sufficiently large sample.	5	Understand how and when the Central Limit Theorem may be applied to the distribution of sample means.
Standard error of the mean.	6	Be able to calculate and interpret the standard error of the mean.
Symmetric confidence intervals for the mean.	7	Understand the term confidence interval and be able to construct confidence intervals for the mean using Normal or t distributions.
	8	Be able to construct and interpret confidence intervals for the difference in mean of paired populations using the Normal or t distribution.
Hypothesis tests: (a) t test for a single mean;	9	Be able to carry out a hypothesis test for a single mean using the t distribution and know when it is appropriate to do so.
(b) paired t test;	10	Be able to carry out a hypothesis test on the difference of means for paired data using the t distribution and know when it is appropriate to do so.
(c) Wilcoxon signed rank test;	11	Be able to carry out a hypothesis test for a single median using the Wilcoxon signed rank test and know when it is appropriate to do so.
(d) Wilcoxon signed rank test;	12	Be able to carry out a hypothesis test for paired data using the Wilcoxon signed rank test and know when it is appropriate to do so.
(e) χ^2 test for goodness of fit.	13	Be able to carry out a χ^2 test for goodness of fit of a model, understanding and using degrees of freedom.

STATISTICS 3, S3

Ref.	Notes	Notation	Exclusions
------	-------	----------	------------

INFERENCE

S3I1	A simple random sample is one in which every possible sample of the given size has an equal probability of being selected.		
2	Simple random sampling, systematic sampling, stratified sampling, cluster sampling, quota sampling (including opportunity sampling).		
3		$\hat{\mu} = \bar{x}$	Proof.
4	$s^2 = \frac{1}{(n-1)} \sum_{i=1}^n (x_i - \bar{x})^2$		Proof.
5	The implication of the Central Limit Theorem.		Formal statement and derivation of the Central Limit Theorem.
6	The standard error of the mean is $\frac{\sigma}{\sqrt{n}}$, if σ is known; otherwise it is estimated as $\frac{s}{\sqrt{n}}$.		
7	In situations where: <ul style="list-style-type: none"> (a) the population variance is known (Normal); (b) the population variance is unknown but the sample size is large (Normal); (c) the sample is small and the population variance is unknown, but the population may be assumed to have a Normal distribution (t). 		
8			
9	In situations where the sample is small and the population variance is unknown, but the population may be assumed to have a Normal distribution.		
10			
11			
12			
13	e.g. uniform distribution, binomial distribution, Poisson distribution, Normal distribution.		

6.16 STATISTICS 4, S4 (4769) A2

Objectives

To provide students with the opportunity to explore ideas in more advanced statistics to a greater depth.

Assessment

Examination (72 marks)

1 hour 30 minutes

There are four options in this unit and there will be one question on each option.

Candidates are expected to answer three questions, each worth 24 marks.

Assumed Knowledge

Candidates are expected to know the content for *C1*, *C2*, *C3* and *C4*, for *FP1* and for *S1*, *S2* and *S3*.

Candidates who wish to study the Generating Functions option must ensure they have appropriate pure mathematics facility in respect of calculus and the summation of series.

Calculators

In the MEI Structured Mathematics specification, no calculator is allowed in the examination for *C1*. For all other units, including this one, a graphical calculator is allowed.

Option 1:

STATISTICS 4, S4		
Specification	Ref.	Competence Statements

ESTIMATION		
------------	--	--

Expectation and variance of a function of a random variable.	S4E1	Be able to find the expectation and variance of a function of a discrete or continuous random variable.
Estimators as random variables.	2	Understand the idea of an estimator as a random variable and its sampling distribution.
Biased and unbiased estimators.	3	Understand the meaning of biased and unbiased estimators.
	4	Be able to determine whether a given estimator is biased or unbiased.
	5	Be able to construct estimators in simple cases.
Unbiased estimators for population mean and variance, from single and pooled samples.	6	Be able to find unbiased estimators for the mean and variance of a population from single and pooled samples.
Maximum likelihood.	7	Understand the meaning of the likelihood of a set of outcomes for a discrete or continuous random variable.
	8	Be able to find the maximum likelihood estimator of a population parameter or parameters, for a discrete or continuous random variable, in simple cases.
Standard error of an estimator.	9	Understand and be able to obtain and use the standard error of an estimator.
Mean square error.	10	Understand the use of mean square error (MSE) for biased estimators.
	11	Be able to obtain a mean square error.
Relative efficiency of estimators.	12	Understand that estimators can be compared by considering their standard errors or mean square errors.

STATISTICS 4, S4

Ref.	Notes	Notation	Exclusions
------	-------	----------	------------

ESTIMATION

S4E1 Random Variables

Discrete: $E[g(X)] = \sum_i g(x_i) p(x_i)$

Continuous: $E[g(X)] = \int g(x) f(x) dx$

$Var[g(X)] = E[(g(X))^2] - (E[g(X)])^2$.

2 Calculation of the sampling distribution in simple cases only.

3

4 $E(\text{estimator}) \neq$ or $=$ parameter value.

5

6 $s^2 = \frac{1}{(n-1)} \sum_{i=1}^n (x_i - \bar{x})^2$ $\hat{\mu} = \bar{x} = \sum_i \frac{x_i}{n}$ Proofs.

Pooled $s^2 = \frac{(n_x - 1)s_x^2 + (n_y - 1)s_y^2}{n_x + n_y - 2}$ $\hat{\mu} = \frac{n_x \bar{x} + n_y \bar{y}}{n_x + n_y}$

7

8

9

10 $MSE(T) = Var(T) + (Bias(T))^2$ $Bias(\hat{\theta}) = E(\hat{\theta}) - \theta$

11

12

Option 2:

STATISTICS 4, S4		
Specification	Ref.	Competence Statements

GENERATING FUNCTIONS		
----------------------	--	--

Probability generating function (pgf).	S4f1	Know that the coefficients of a generating function represent probabilities for a discrete random variable.
	2	Understand the uniqueness of the relationship between a distribution and its probability generating function.
Derivation of the pgf of a discrete random variable.	3	Be able to derive a probability generating function for a discrete random variable from its probability distribution.
Use of the pgf to find the distribution of the sum of random variables.	4	Know that the probability generating function of a sum of two or more independent discrete random variables is the product of their probability generating functions and be able to use this.
Use of the pgf to find the mean and variance of a random variable.	5	Be able to derive the mean and variance of a discrete random variable from its pgf.
	6	Be able to derive the probability generating function of a linear transformation of a random variable.
Moment generating function (mgf).	7	Know that the coefficients of a generating function may be used to derive moments for a discrete or continuous random variable.
	8	Understand the uniqueness of the relationship between a distribution and its moment generating function.
Derivation of the mgf of a random variable.	9	Be able to derive a moment generating function for a discrete or continuous random variable given its probability function or probability density function.
Use of the mgf to find the distribution of the sum of random variables.	10	Know that the moment generating function of a sum of two or more independent random variables is the product of their moment generating functions and be able to use this.
Use of the mgf to find the mean and variance of a random variable.	11	Be able to derive the mean and variance of a random variable by inspection of coefficients or differentiation.
	12	Be able to derive the moment generating function of a linear transformation of a random variable.

STATISTICS 4, S4

Ref.	Notes	Notation	Exclusions
------	-------	----------	------------

GENERATING FUNCTIONS

S4f1		pgf $G_X(t) = E(t^X)$ $G'_X(t) = \frac{d}{dt}[G_X(t)]$	
2			
3			
4			
5			
6			
7		mgf $M_X(\theta) = E[e^{\theta X}]$ $M'_X(\theta) = \frac{d}{d\theta}[M_X(\theta)]$	Characteristic functions.
8			
9			
10			
11			
12			

Option 3:

STATISTICS 4, S4		
Specification	Ref.	Competence Statements

INFERENCE		
-----------	--	--

Two-sample and paired tests.	S4I1	Understand the difference between a two-sample test and a paired sample test.
Test for the difference of means of unpaired samples.	2	Know when to use the Normal distribution and when to use the t distribution in testing for differences of population means.
	3	Know when to use pooled unbiased estimators for common mean and variance for samples from two populations and be able to do so.
Test for the difference of medians of unpaired samples using the Wilcoxon (Mann-Whitney) rank sum test.	4	Know when to use the Wilcoxon rank sum (Mann-Whitney) test for differences of population medians.
Confidence intervals for the difference of means of unpaired populations.	5	Be able to construct and interpret confidence intervals for the difference in mean of unpaired populations using the t distribution.
Type I and Type II errors.	6	Know what is meant by a Type I and a Type II error in a hypothesis test.
	7	Understand that the probability of a Type I error is the significance level of the test.
	8	Understand that the probability of a Type II error depends on the true population distribution, which is unknown, as well as the sample size and significance level.
Operating characteristic, power function.	9	Be able to calculate the probability of a Type II error in a specific case.
	10	Be able to calculate, plot and interpret the operating characteristic and the power function of a hypothesis test.

STATISTICS 4, S4

Ref.	Notes	Notation	Exclusions
------	-------	----------	------------

INFERENCE

S4I1	Candidates are reminded that the content of earlier units may be examined in a later unit. Thus questions may be set in this unit on paired samples, and the associated tests and confidence intervals, even though this is first met in Statistics 3.											
2	Normal: population variance(s) known or estimated from large sample(s). <i>t</i> : population variance(s) estimated from small sample(s), underlying Normality assumed.											
3		$s^2 = \frac{(n_1 - 1)s_1^2 + (n_2 - 1)s_2^2}{n_1 + n_2 - 2}$										
4			Recall of the mean and variance of the test statistic.									
5	Normal: population variance(s) known or estimated from large sample(s). <i>t</i> : population variance(s) estimated from small sample(s), underlying Normality assumed. Candidates are reminded of the Note to S4I1, above.											
6	<table style="width: 100%; border: none;"> <tr> <td style="width: 33%;">H₀ true</td> <td style="width: 33%;">H₀ accepted</td> <td style="width: 33%;">H₀ rejected</td> </tr> <tr> <td></td> <td>Correct result</td> <td>Type I error</td> </tr> <tr> <td>H₀ false</td> <td>Type II error</td> <td>Correct result</td> </tr> </table> <p>Questions on Type I and Type II errors may be based on tests first met in earlier units.</p>	H₀ true	H₀ accepted	H₀ rejected		Correct result	Type I error	H₀ false	Type II error	Correct result		
H₀ true	H₀ accepted	H₀ rejected										
	Correct result	Type I error										
H₀ false	Type II error	Correct result										
7												
8												
9												
10	Operating characteristic = P (Type II error the true value of the parameter) Power = 1 – Operating characteristic.											

Option 4:

STATISTICS 4, S4		
Specification	Ref.	Competence Statements

DESIGN AND ANALYSIS OF EXPERIMENTS		
Principles of experimental design.	S4x1	Be able to explain the need for randomisation and replication in a particular experimental design.
	2	Be able to explain the purpose of particular designs in given simple situations.
	3	Be able to suggest a suitable experimental design for a given simple situation.
One-way analysis of variance.	4	Understand the usual one-way analysis of variance model, for the case of common population variance.
	5	Know that a one-way analysis of variance is used to test for equality of population means.
	6	Be able to carry out a one-way analysis of variance using an F test.
	7	Be able to interpret the conclusions of such a test.

STATISTICS 4, S4			
Ref.	Notes	Notation	Exclusions

DESIGN AND ANALYSIS OF EXPERIMENTS

S4x1

2	Completely randomised designs, paired comparisons, randomised blocks, Latin squares.
---	--

3	Completely randomised designs, paired comparisons, randomised blocks, Latin squares.
---	--

4	
---	--

5	
---	--

6	
---	--

7	
---	--

6.17 DECISION MATHEMATICS 1, D1 (4771) AS

Objectives

To give students experience of modelling and of the use of algorithms in a variety of situations.

To develop modelling skills.

The problems presented are diverse and require flexibility of approach. Students are expected to consider the success of their modelling, and to appreciate the limitations of their solutions.

Assessment

Examination (72 marks)

1 hour 30 minutes

The examination paper has two sections:

Section A: three questions, each worth 8 marks

Section Total: 24 marks

Section B: three questions each worth 16 marks

Section Total: 48 marks

Assumed Knowledge

Candidates are expected to know the content of Intermediate Tier GCSE*.

*See note on page 34.

Calculators

In the MEI Structured Mathematics specification, no calculator is allowed in the examination for *CI*. For all other units, including this one, a graphical calculator is allowed.

DECISION MATHEMATICS 1, D1

Specification	Ref.	Competence Statements
---------------	------	-----------------------

MODELLING

The three units in Decision Mathematics are based on the use of the modelling cycle in solving problems

The modelling cycle applied to real-world problems.	D1p1	Be able to abstract from a real world problem to a mathematical model.
	2	Be able to analyse the model appropriately.
	3	Be able to interpret and communicate results.
	4	Be able progressively to refine a model as appropriate.

ALGORITHMS

Background and definition.	D1A1	Be able to interpret and apply algorithms presented in a variety of formats.
	2	Be able to develop and adapt simple algorithms.

Basic ideas of complexity.	3	Understand the basic ideas of algorithmic complexity.
	4	Be able to analyse the complexity of some of the algorithms covered in this specification.

GRAPHS

Background and definitions.	D1g1	Understand notation and terminology.
-----------------------------	------	--------------------------------------

Use in problem solving.	2	Be able to model appropriate problems by using graphs.
-------------------------	---	--

NETWORKS

Definition.	D1N1	Understand that a network is a graph with weighted arcs
-------------	------	---

Use in problem solving.	2	Be able to model appropriate problems by using networks
-------------------------	---	---

The minimum connector problem.	3	Know and be able to use Kruskal's and Prim's algorithms
--------------------------------	---	---

The shortest path from a given node to other nodes.	4	Know and be able to apply Dijkstra's algorithm
---	---	--

DECISION MATHEMATICS 1, D1			
Ref.	Notes	Notation	Exclusions

MODELLING

The three units in Decision Mathematics are based on the use of the modelling cycle in solving problems

D1p1	Approximation and simplification.		
2	Solution using an appropriate algorithm.		
3	Implications in real world terms.		
4	Check against reality; adapt standard algorithms.		

ALGORITHMS

D1A1	Flowcharts; written English; pseudo-code.		
2	To include sorting and packing algorithms. Sorting: Bubble, Shuttle, insertion, quick sort. Packing: Full-bin, first-fit, first-fit decreasing. Candidates will be expected to know these packing algorithms.		Candidates will not be required to memorise sorting algorithms.
3	Worst case; size of problem; that for quadratic algorithms doubling the size of a large problem can quadruple the solution time, etc.	Order notation, e.g. $O(n^2)$ for quadratic complexity.	
4	Kruskal; Prim (network and tabular forms); Dijkstra. The requirements will also apply to algorithms in later modules (D2 and DC) at the stage when they are met.		

GRAPHS

D1g1	Nodes/vertices; arcs/edges; trees; node order; simple, complete, connected and bipartite graphs; walks, trails, cycles and Hamilton cycles; trees; digraphs; planarity.	Pictures (i.e. graphs), incidence matrices.	
2	e.g. Königsberg bridges; various river crossing problems; the tower of cubes problem; filing systems.		

NETWORKS

D1N1			
2	Use in modelling 'geographical' problems and other problems e.g. translating a book into different languages, e.g. the knapsack problem.		
3	Kruskal's algorithm in graphical form only. Prim's algorithm in graphical or tabular form.		
4			

DECISION MATHEMATICS 1, D1

Specification	Ref.	Competence Statements
---------------	------	-----------------------

LINEAR PROGRAMMING

Linear inequalities in two or more variables.	D1L1	Be able to manipulate inequalities algebraically.
	2	Be able to illustrate linear inequalities in two variables graphically.
Formulation of constrained optimisation problems.	3	Be able to formulate simple maximisation of profit and minimisation of cost problems.
Solution of constrained optimisation problems.	4	Be able to use graphs to solve 2-D problems, including integer valued problems.
Algebraic interpretation of the graphical solution in 2 dimensions.	5	Be able to interpret solutions, including spare capacities.

CRITICAL PATH ANALYSIS

Using networks in project management.	D1X1	Be able to construct and use a precedence network.
	2	Be able to construct and interpret a cascade chart.
	3	Be able to construct and interpret a resource histogram.
	4	Understand the use of alternative criteria in project optimisation.
	5	Be able to crash a network.

SIMULATION

Random variables.	D1Z1	Know how to generate realisations of a discrete uniformly distributed random variable.
	2	Be able to use random variables to model discrete non-uniform random variables.
Simulation modelling.	3	Be able to build and use simple models.
	4	Be able to interpret results.
	5	Understand the need for repetition.

DECISION MATHEMATICS 1, D1			
Ref.	Notes	Notation	Exclusions

LINEAR PROGRAMMING			
--------------------	--	--	--

D1L1			
2			Non-linear problems.
3		$\text{Max } 2x + 3y$ s.t. $x + y \leq 6$ $5x + 2y \leq 12$ $x \geq 0, y \geq 0$	Non-linear problems
4	Showing alternating feasible points and their associated costs/profits.		Solving problems in more than 2 dimensions.
5			

CRITICAL PATH ANALYSIS			
------------------------	--	--	--

D1X1	Including forward and backward passes, the identification of critical activities and the calculation of float (total and independent).	Activity on arc.	Knowledge of an algorithm for constructing a precedence network from a precedence table. Knowledge of an algorithm for numbering activities. Knowledge of an algorithm for resource smoothing.
2			
3			
4	Time; cost; use of resources.		
5	Checking critical activities and for activities becoming critical.		

SIMULATION			
------------	--	--	--

D1Z1	Drawing numbers from a hat; coins; dice; pseudo-random numbers from a calculator; simple pseudo-random number generators; random number tables.		Continuous random variables.
2	Cumulative frequency methods, including rejecting values where necessary.		
3	Hand simulations, including queuing situations.		
4			
5			

6.18 DECISION MATHEMATICS 2, D2 (4772) A2

Objectives

To give students experience of modelling and of the use of algorithms in a variety of situations.

To develop modelling skills.

The problems presented are diverse and require flexibility of approach. Students are expected to consider the success of their modelling, and to appreciate the limitations of their solutions.

Assessment

Examination (72 marks)
1 hour 30 minutes
Candidates answer all four questions.

Two questions, each worth about 16 marks and
two questions, each worth about 20 marks.

Assumed Knowledge

Candidates are expected to know the content of *C1* and *C2* and *D1*.

Calculators

In the MEI Structured Mathematics specification, no calculator is allowed in the examination for *C1*. For all other units, including this one, a graphical calculator is allowed.

DECISION MATHEMATICS 2, D2		
Specification	Ref.	Competence Statements

LINEAR PROGRAMMING		
--------------------	--	--

The simplex algorithm.	D2L1	Be able to solve simple maximisation problems with \leq constraints and with two or more variables.
Geometric interpretation.	2	Be able to identify tableaux (initial, intermediate and final) with feasible points, particularly in the case of problems involving two or three variables.
\geq inequalities.	3	Know and be able to apply the two-stage simplex and the big-M methods to construct an initial feasible solution to problems involving \geq constraints.
Equality constraints.	4	Understand how to model an equality constraint by using a pair of inequality constraints.
Problem solving.	5	Be able to formulate and solve a variety of problems as linear programming problems, and be able to interpret the solutions.

NETWORKS		
----------	--	--

The shortest path between any two nodes in a connected Network.	D2N1	Know and be able to apply Dijkstra's algorithm repeatedly.
	2	Know and be able to apply Floyd's algorithm.
	3	Be able to analyse the complexity of Dijkstra's and Floyd's algorithms.
The travelling salesperson problem (TSP).	4	Be able to convert the practical problem into the classical problem.
	5	Be able to interpret a solution to the classical problem in terms of a solution to an underlying practical problem.
	6	Be able to analyse the complexity of complete enumeration.
	7	Be able to construct an upper bound for the solution to the classical problem.
	8	Be able to construct a lower bound for the solution to the classical problem.
The route inspection (Chinese postperson) problem (CPP).	9	Know and be able to apply the route inspection algorithm.
	10	Be able to analyse the complexity of the algorithm.

DECISION MATHEMATICS 2, D2			
Ref.	Notes	Notation	Exclusions

LINEAR PROGRAMMING			
--------------------	--	--	--

D2L1	The tabular form of algorithm.		Any consideration of the complexity of the algorithm.
2	Showing alternative feasible points and their costs.		
3	Including the possibility that there is no feasible solution.		
4			
5	Problems will not be restricted to maximisation problems with \leq constraints, such as production planning problems involving the maximisation of profit or contribution subject to resource constraints. Instead they will encompass blending problems, shortest path problems, stock cutting problems, etc.		Non-linear problems, methods for solving integer programming problems.

NETWORKS			
----------	--	--	--

D2N1			
2			
3	Floyd and the repeated application of Dijkstra both have cubic complexity.		
4	Practical problem: revisiting vertices allowed; network not necessarily complete.		
5	Classical problem: no revisiting allowed; network complete.		
6	Problems of factorial complexity.		
7	Using the nearest neighbour algorithm.		Tour-to-tour improvement algorithms.
8	Using a minimum connector of a reduced network.		
9	Pairing of odd nodes and repeating shortest paths between the members of each pair.		
10	$\frac{(2n)!}{2^n n!}$ ways of pairing $2n$ odd nodes.		

DECISION MATHEMATICS 2, D2		
Specification	Ref.	Competence Statements

LOGIC		
-------	--	--

Propositions and connectivity.	D2p1	Know and understand how to form compound propositions by using \sim , \wedge , \vee , \Leftrightarrow and \Rightarrow .
	2	Be able to use truth tables to analyse propositions.
Switching and combinatorial circuits.	3	Be able to model compound propositions with simple switching and combinatorial circuits.
	4	Be able to manipulate Boolean expressions involving \sim , \wedge and \vee using the distributive laws, de Morgan's law, etc.

DECISION TREES		
----------------	--	--

Using networks in decision analysis.	D2N1	Be able to construct and interpret simple decision trees.
	2	Be able to use expected monetary values (EMVs) to compare alternatives.
	3	Be able to use utility to compare alternatives.

DECISION MATHEMATICS 2, D2			
Ref.	Notes	Notation	Exclusions

LOGIC			
-------	--	--	--

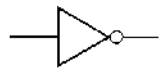
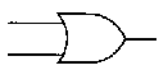
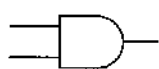
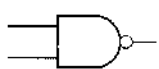
D2p1			Propositions will be represented by lower case alphabetic characters.
2			More than 3 propositions.
3	Logic gates:		
	NOT 	OR 	
	AND 	NAND 	

4	Candidates will be expected to use (Boolean) algebraic manipulation to prove that simple Boolean expressions are equivalent.		
---	--	--	--

DECISION TREES			
----------------	--	--	--

D2N1			
2	Candidates will need to be able to distinguish between, and handle, decision and chance nodes.	EMV.	Explicit knowledge of Bayes' theorem.
3		Decision nodes:	Chance nodes:

6.19 DECISION MATHEMATICS COMPUTATION, DC (4773) A2

Objectives

To give students experience of modelling with the aid of suitable software and of the use of algorithms in a variety of situations.

To develop modelling skills with the aid of suitable software.

The problems presented are diverse and require flexibility of approach. Students are expected to consider the success of their modelling, and to appreciate the limitations of their solutions.

Assessment

Examination (72 marks)
2½ hours
Candidates answer four questions.
Each question is worth about 18 marks.

Candidates require access to a computer with a spreadsheet program and a linear programming package, and suitable printing facilities, throughout the examination.

Assumed Knowledge

Candidates are expected to know the content of *C1* and *C2* and *D1*.

Calculators

In the MEI Structured Mathematics specification, no calculator is allowed in the examination for *C1*. For all other units, including this one, a graphical calculator is allowed.

DECISION MATHEMATICS COMPUTATION, DC

Specification	Ref.	Competence Statements
---------------	------	-----------------------

NETWORK FLOWS

Using networks to model transmission systems.	DCN1	Be able to model a transmission system using a network.
Maximum flow/minimum cut theorem.	2	Be able to specify a cut and to calculate its capacity.
	3	Understand that if an established flow is equal to the capacity of an identified cut, then the flow is maximal and the cut is a minimum cut.
Flow augmentation.	4	Be able to use flow augmentation and the labelling algorithm to establish a maximum flow in simple transmission networks (directed and undirected).
Linear programming formulation.	5	Be able to formulate and solve network flow problems as linear programming problems.

MATCHINGS

Bipartite graphs.	DCM1	Be able to identify when a bipartite graph is an appropriate model.
	2	Be able to construct a bipartite graph.
The matching algorithm.	3	Be able to construct an alternating path and use it to improve a matching.
	4	Be able to model a matching problem as a network flow problem.
Allocation and transportation.	5	Be able to recognise and formulate allocation and transportation problems.
LP formulation.	6	Be able to formulate and solve matching, allocation and transportation problems as linear programming problems.

LINEAR PROGRAMMING

Problem solving.	DCL1	Be able to formulate and solve (using a computer package) a wide variety of problems as linear programming problems.
	2	Be able to interpret the solutions of linear programming problems.

DECISION MATHEMATICS COMPUTATION, DC

Ref.	Notes	Notation	Exclusions
------	-------	----------	------------

NETWORK FLOWS

DCN1	Single and super sources and sinks. Flow in = Flow out for other nodes.	Source: S Sink: T	
2	Describing a cut symbolically.	e.g. SA BCT	
3			
4			Consideration of the complexity of the flow augmentation algorithm.
5			

MATCHINGS

DCM1			
2			
3	Maximal matchings; complete matchings.		
4			
5	To include the use of dummies as required.		The Hungarian and transportation algorithms.
6			

LINEAR PROGRAMMING

DCL1	Problems will not be restricted to maximisation problems with \leq constraints: e.g. blending problems; shortest path problems; stock cutting problems. The variety should be wide, e.g. flows in networks; matchings; allocation problems; transportation problems; set covering; set packing; maximin and minimax problems. (The allocation problem, and other similar problems require integer solutions, but their structure is such that linear programming guarantees an integer solution.) Problems requiring the setting up and use of indicator variables, e.g. modelling 'fixed cost if used' situations. Simple integer problems, e.g. the knapsack problem.		The theory of integer programming.
2			

DECISION MATHEMATICS COMPUTATION, DC

Specification	Ref.	Competence Statements
---------------	------	-----------------------

RECURRENCE RELATIONS

Use in problem solving.	DCs1	Be able to model appropriate problems by using recurrence relations.
Solving recurrence relations.	2	Be able to solve first and second order homogeneous and non-homogeneous relations.
	3	Be able to produce, manipulate and interpret spreadsheet models of recurrence relations (including second order oscillatory relations).

SIMULATION

Simulation modelling.	DCZ1	Be able to build and use discrete event/ discrete time simulation models.
	2	Be able to use a spreadsheet function to generate uniformly distributed random numbers (discrete and continuous).
	3	Be able to use spreadsheet functions to transform uniform discrete random variables to non-uniform discrete random variables.
	4	Be able to determine approximately the number of repetitions needed to obtain a required level of accuracy.
	5	Be able to verify and validate a model.
	6	Be able to interpret results.
Computer modelling.	7	Be able to use a spreadsheet package to build, run and interpret simulation models.

DECISION MATHEMATICS COMPUTATION, DC

Ref.	Notes	Notation	Exclusions
------	-------	----------	------------

RECURRENCE RELATIONS

DCs1

- | | | | |
|---|---|--|---|
| 2 | Second order homogeneous equations will have constant coefficients. Those to be solved analytically will have real roots.
Candidates will be expected to solve equations of the form $a^x = b$. | | An extensive knowledge of particular solutions. |
|---|---|--|---|

3

SIMULATION

DCZ1	Hand simulations.		Continuous random variables.
------	-------------------	--	------------------------------

- | | | | |
|---|--|--|--|
| 2 | Computer simulations using spreadsheets. | | |
|---|--|--|--|

3

- | | | | |
|---|---|--|--|
| 4 | Use of standard error of output variable. | | |
|---|---|--|--|

- | | | | |
|---|--|--|--|
| 5 | Verification: checking that the model functions according to specifications. | | |
|---|--|--|--|

- | | | | |
|---|--|--|--|
| 6 | Validation: checking that a model adequately reflects reality. | | |
|---|--|--|--|

7

6.20 NUMERICAL METHODS, NM (4776) AS

Objectives

To provide students with an understanding that many mathematical problems cannot be solved analytically but require numerical methods.

To develop a repertoire of simple numerical methods and to give experience in using them.

To state or prove theoretical results about the accuracy of these numerical techniques and to demonstrate the control of error in practice.

To implement these numerical methods on computers and to develop an awareness of the difficulties which can arise when computers are used to do mathematics.

Assessment

Examination (72 marks)
1 hour 30 minutes
The examination paper has two sections:

Section A: 5 - 7 questions, each worth at most 8 marks.
Section Total: 36 marks

Section B: two questions, each worth about 18 marks.
Section Total: 36 marks

Coursework (18 marks)
There is one assignment.

Assumed Knowledge

Candidates are expected to know the content of *C1* and *C2*.

Calculators

In the MEI Structured Mathematics specification, no calculator is allowed in the examination for *C1*. For all other units, including this one, a graphical calculator is allowed.

NUMERICAL METHODS, NM

Specification	Ref.	Competence Statements
---------------	------	-----------------------

SOLUTION OF EQUATIONS

Bisection method. False Position (linear interpolation). Secant method. Fixed point iteration. Newton-Raphson method.	NMe1	Understand the graphical interpretations of these methods.
	2	Know how to solve equations to any required degree of accuracy using these methods.
	3	Understand the relative computational merits and possible failure of the methods.
	4	Know that fixed point iteration generally has first order convergence, Newton-Raphson generally has second order convergence.

ERRORS

Absolute and relative error.	NMv1	Know how to calculate errors in sums, differences, products and quotients.
	2	Know how to calculate the error in $f(x)$ when there is an error in x .
	3	Understand the effects on errors of changing the order of a sequence of operations.
	4	Understand that computers represent numbers to limited precision.
	5	Understand the consequences of subtracting nearly equal numbers.

NUMERICAL DIFFERENTIATION

Forward difference method. Central difference method.	NMc1	Know how to estimate a derivative using the forward and central difference methods with a suitable value (or sequence of values) of h .
	2	Have an empirical and graphical appreciation of the greater accuracy of the central difference formula.

NUMERICAL INTEGRATION

Mid-point rule. Trapezium rule. Simpson's rule.	NMc3	Be able to evaluate a given definite integral to any desired degree of accuracy using these methods.
	4	Know the order of errors of the midpoint and trapezium rules. Understand the development of Simpson's rule from the midpoint and the trapezium rules.

NUMERICAL METHODS, NM			
Ref.	Notes	Notation	Exclusions

SOLUTION OF EQUATIONS			
-----------------------	--	--	--

NMe1	Staircase and cobweb diagrams.		Proofs of orders of convergence.
2			
3			
4			

ERRORS			
--------	--	--	--

NMv1		Exact value: x Approximate value: X Absolute error: $X - x$ Relative error: $\frac{X - x}{x}$.	
2	$f(x + h) \approx f(x) + hf'(x)$		Functions of more than one variable.
3			
4			
5			

NUMERICAL DIFFERENTIATION			
---------------------------	--	--	--

NMc1		$f'(x) \approx \frac{f(x+h) - f(x)}{h}$ $f'(x) \approx \frac{f(x+h) - f(x-h)}{2h}$	
2			

NUMERICAL INTEGRATION			
-----------------------	--	--	--

Nmc3		M_n : midpoint rule with n strips T_n : trapezium rule with n strips S_{2n} : Simpson's rule with $2n$ strips.	
4	$T_{2n} = \frac{1}{2}(M_n + T_n)$ $S_{2n} = \frac{1}{3}(2M_n + T_n) = \frac{1}{3}(4T_{2n} - T_n)$		

NUMERICAL METHODS, NM		
Specification	Ref.	Competence Statements

APPROXIMATIONS TO FUNCTIONS		
-----------------------------	--	--

Newton's forward difference interpolation method.	NMf1	Be able to use Newton's forward difference interpolation formula to reconstruct polynomials and to approximate functions.
Lagrange's form of the interpolating polynomial.	2	Be able to construct the interpolating polynomial of degree n given a set of $n + 1$ data points.

NUMERICAL METHODS, NM			
Ref.	Notes	Notation	Exclusions

APPROXIMATIONS TO FUNCTIONS			
-----------------------------	--	--	--

NMf1	Functions tabulated at equal intervals	$\Delta f(x) = f(x+h) - f(x)$	
------	--	-------------------------------	--

2

Numerical Methods (NM) Coursework

Rationale

This module aims to develop skills in the areas of problem identification, use of numerical methods and control of error in practice. The coursework assignment should enable students to demonstrate a facility with technology and an awareness of the difficulties that can arise when computers are used to do mathematics.

Description

Students are expected to investigate a problem which is suitable for numerical solution, using one of the methods in the specification. (Problems which have analytical solutions are acceptable only if the analytical solution is too time-consuming, or too advanced, to be feasible.) Students should use a computer to develop a solution which is both efficient and accurate. In particular they must show how the desired accuracy has been achieved, either by means of sufficient iterations of the numerical process to ensure that the accuracy has been achieved, or by means of a theoretical analysis of errors.

Since it is assumed that the coursework will be implemented on a computer, the coursework will often arise naturally from the work done in the module.

The coursework counts for 20% of the total assessment for this unit.

Assessment

The task must be assessed on the coursework assessment sheets.

Numerical Methods (NM) Coursework: Assessment Sheet

Task: Candidates are expected to investigate a problem which is suitable for numerical solution, using one of the methods in the specification.

Coursework Title											
Candidate Name					Candidate Number						
Centre Number						Date					
Domain	Mark	Description					Comment	Mark			
Problem specification	1	An appropriate problem is identified.									
	1	There is a correct explanation of why it is appropriate for numerical solution.									
Strategy	1	An appropriate procedure is used.									
	1	The candidate explains why the procedure to be adopted is appropriate to the problem.									
Formula application	1	There is an application of routine algorithms and methods, which is at least partially correct.									
	1	There is a substantial application of routine algorithms and methods which is largely correct.									
	1	The application is fully correct.									
Use of technology	1	Appropriate use is made of calculator or computer software.									
	1	It is clearly explained.									
Error analysis	1	There is a competent analysis of errors, but it may be brief.									
	1	The analysis is developed for the particular problem, either from theoretical formulae or iteration of methods to achieve convergence.									
	1	This development leads to an improved solution.									
Interpretation	1	The solution is clearly expressed.									
	1	The solution is produced to a high degree of accuracy (e.g. 6 significant figures).									
	1	In addition there is a discussion of the validity of the solution.									
	1	Possible limitations are identified.									
Oral communication	2	Presentation		Please tick at least one box and give a brief report.							
		Interview									
		Discussion									
Half marks may be awarded but the overall total must be an integer.							TOTAL	18			
Please report overleaf on any help that the candidate has received beyond the guidelines											

Coursework must be available for moderation by OCR

6.21 NUMERICAL COMPUTATION, NC (4777) A2

Objectives

To extend the repertoire of techniques developed in *Numerical Methods* and, with the aid of suitable software, to give experience in using them.

To state or prove theoretical results about the accuracy of these numerical techniques and, with the aid of suitable software, to demonstrate the control of error in practice.

To implement these numerical methods on computers and to be aware of the difficulties which can arise in doing so.

Assessment

Examination (72 marks)
2 hours 30 minutes
Candidates answer three questions out of four.
Each question is worth 24 marks.

Candidates require access to a computer with a spreadsheet program, and suitable printing facilities, throughout the examination.

Assumed Knowledge

Candidates are expected to know the content of *C1*, *C2*, *C3* and *C4* and *NM*.

Calculators

In the MEI Structured Mathematics specification, no calculator is allowed in the examination for *C1*. For all other units, including this one, a graphical calculator is allowed.

NUMERICAL COMPUTATION, NC

Specification	Ref.	Competence Statements
---------------	------	-----------------------

SOLUTION OF EQUATIONS

Relaxation. Richardson's method. Aitken's delta squared method.	NCe1	Be able to use relaxation and the methods of Richardson and Aitken to accelerate convergence.
---	------	---

NUMERICAL INTEGRATION

Romberg's method.	NCc1	Be able to perform Romberg integration on definite integrals.
----------------------	------	---

Gaussian methods.	2	Understand the principles of Gaussian methods.
	3	Be able to apply Gaussian methods to the evaluation of integrals.

DIFFERENTIAL EQUATIONS

The Euler Method. The modified Euler method (Runge- Kutta order 2).	NCc4	Know how to solve a given first order differential equation $\frac{dy}{dx} = f(x, y)$ with initial conditions to any required degree of accuracy by repeated application of these methods.
---	------	--

	5	Understand that the modified Euler method converges more rapidly than the Euler method.
--	---	---

Predictor- corrector methods.	6	Be able to solve first order differential equations using predictor-corrector methods.
----------------------------------	---	--

Runge-Kutta methods.	7	Understand the concepts underlying the Runge-Kutta methods.
-------------------------	---	---

	8	Be able to solve first order differential equations using Runge-Kutta methods.
--	---	--

	9	Understand that higher order Runge-Kutta methods converge more rapidly than lower order methods.
--	---	--

Finite difference methods.	10	Be able to use finite difference methods for solving second order differential equations.
-------------------------------	----	---

NUMERICAL COMPUTATION, NC

Ref.	Notes	Notation	Exclusions
------	-------	----------	------------

SOLUTION OF EQUATIONS

NCe1

Error terms.

NUMERICAL INTEGRATION

NCc1 Candidates will be expected to understand the difference between local error and global error in integration formulae. The notation used for Romberg's method will be explained within any examination question.

No standard notation will be required for Romberg's method.

2

3

DIFFERENTIAL EQUATIONS

NCc4

$$y_{n+1} \approx y_n + hf(x_n, y_n)$$

$$k_1 = hf(x_n, y_n)$$

$$k_2 = hf(x_n + h, y + k_1)$$

$$y_{n+1} \approx y_n + \frac{1}{2}(k_1 + k_2)$$

5

6

7 Candidates will be expected to know the standard Runge-Kutta method of order 4 but may be asked to work with other methods, given sufficient information.

$$k_1 = hf(x, y)$$

$$k_2 = hf\left(x + \frac{h}{2}, y + \frac{k_1}{2}\right)$$

$$k_3 = hf\left(x + \frac{h}{2}, y + \frac{k_2}{2}\right)$$

$$k_4 = hf(x + h, y + k_3)$$

$$y_{n+1} \approx y_n + \frac{1}{6}(k_1 + 2k_2 + 2k_3 + k_4)$$

8

9

10 Central difference formula for $\frac{d^2 y}{dx^2}$

$$\frac{d^2 y}{dx^2} \approx \frac{f(x+h) - 2f(x) + f(x-h)}{h^2}$$

NUMERICAL COMPUTATION, NC		
Specification	Ref.	Competence Statements

APPROXIMATION TO FUNCTIONS		
-----------------------------------	--	--

Least squares.	NCc11	Be able to approximate data by simple functions (e.g. quadratics and cubics) using the least squares method.
Newton's divided difference method.	12	Be able to interpolate polynomials and approximate values of functions from tabulated data, using Newton's divided difference formula.

LINEAR ALGEBRA		
-----------------------	--	--

Gaussian elimination. Pivoting. Matrix inversion. Determinants.	NCm1	Be able to solve systems of linear equations, invert matrices, find determinants using Gaussian elimination and pivoting strategies.
Gauss-Jacobi method. Gauss-Seidel method.	2	Be able to solve systems of linear equations using iterative methods. Understand and use the condition of diagonal dominance.

NUMERICAL COMPUTATION, NC			
Ref.	Notes	Notation	Exclusions

APPROXIMATION TO FUNCTIONS

NCc11

12

LINEAR ALGEBRA

NCm1

2

6.22 FURTHER PURE MATHEMATICS WITH TECHNOLOGY, FPT (4798) A2

Objectives

To build on and extend students' knowledge of Pure Mathematics through using technology to:

- perform mathematical processes quickly and accurately;
- observe the effect of changing parameters displayed in different representations, which is useful for aiding generalisation;
- engage in investigative approaches to problem solving.

Assessment

Examination (72 marks)
Up 2 hours
All questions are compulsory.
Three questions each worth about 24 marks.

Candidates require access to a computer with a computer algebra system (CAS), graphing software, spreadsheet program and programming language throughout the examination.

Assumed Knowledge

Candidates are expected to know the content of *C1*, *C2*, *C3*, *C4*, *FP1* and the Complex Numbers, Polar curves, Power Series and Hyperbolic Functions sections of *FP2*.

Calculators

In the MEI Structured Mathematics specification, no calculator is allowed in the examination for *C1*. For all other units, including this one, a graphical calculator is allowed.

Computer Software

Centres must complete a form seeking approval from OCR for the software they intend to use for the examination. The form is available on the website (www.ocr.org.uk) or by requesting it from ocrmathematics@ocr.org.uk. Centres can obtain advice from MEI about suitable software (www.mei.org.uk).

Use of CAS

Candidates may use CAS for any of the algebraic processes in this unit such as solving, factorising, expanding, differentiating, integrating and finding limits. However, candidates should take care to give sufficient evidence when answering “show that” questions.

FURTHER PURE MATHEMATICS WITH TECHNOLOGY, FPT

Specification	Ref.	Competence Statements
---------------	------	-----------------------

INVESTIGATION OF CURVES

In this topic students develop skills associated with curves. They learn to look for and recognise important properties of curves, making appropriate use of graphing software and CAS. They are expected to be able to generalise their findings; at times this will require analytical skills.

Examination questions will use a variety of curves but candidates will not be expected to know their particular properties. Instead the questions will test candidates' ability to select and apply the skills to investigate them. It is, however, anticipated that while studying this option, students will meet a wide selection of curves including curves expressed as cartesian equations, parametric equations and polar curves. Candidates will be expected to use CAS to solve equations and evaluate derivatives.

Curves.	FPTC1	Know and use the vocabulary associated with curves.
Graphing Software	2	Know how to plot a family of curves in graphing software.
Properties of Curves.	3	Be able to find, describe and generalise properties of curves.
	4	Be able to determine asymptotes.
	5	Be able to find the gradient of the tangent to a curve at a point.
	6	Be able to find and work with equations of chords, tangents and normals.
	7	Be able to use the limit of $f(x)$ as $x \rightarrow a$ or $x \rightarrow \infty$ to deduce and investigate properties of a curve.
	8	Be able to identify cusps by examining the behaviour nearby.

FURTHER PURE MATHEMATICS WITH TECHNOLOGY, FPT			
Ref.	Notes	Notation	Exclusions

INVESTIGATION OF CURVES

FPTC1	e.g. asymptote, cusp, loop, node; terms relating to symmetry. Students should know the names and shapes of conics.
-------	--

2	Students will be expected to be able to use sliders for parameters.
---	---

3	Generalisation may involve exploratory use of graphing software. Any algebraic work may involve the exploratory use of CAS. Curves may be given in cartesian, polar or parametric form.
---	---

4	Including oblique asymptotes and asymptotic approach to curves.
---	---

5	The general form of the formula for the gradient of a tangent to a polar curve will be given if required.
---	---

6	Derivatives can be found with CAS.
---	------------------------------------

7	Limits can be found with CAS.
---	-------------------------------

8	Examining the limit of the gradient as the curve approaches the cusp from both directions.
---	--

FURTHER PURE MATHEMATICS WITH TECHNOLOGY, FPT

Specification	Ref.	Competence Statements
---------------	------	-----------------------

FUNCTIONS OF COMPLEX VARIABLES

Students will be expected to use the complex number capabilities of CAS. The use of spreadsheets is expected for iterations and limits. i will be used for $\sqrt{-1}$ throughout.

Functions	FPTj1	Understand what a function of a complex variable is and be able to identify the real and imaginary parts of a function.
Equations	2	Be able to interpret the solution of an equation given by CAS.
	3	Understand that the roots of a polynomial with complex coefficients will be complex numbers.
	4	Be able to find and use the roots of a polynomial with complex coefficients.
Differentiation	5	Be able to differentiate polynomials, $\sin z$, $\sinh z$, $\cos z$, $\cosh z$, e^z .
Indefinite integration	6	Be able to find the indefinite integrals of polynomials, $\sin z$, $\sinh z$, $\cos z$, $\cosh z$, and e^z .
Limits	7	Be able to use the limit of a function of a complex variable.
	8	Be able to construct a spreadsheet to demonstrate how a function behaves as it tends to a limit.
Trigonometric, hyperbolic and exponential functions	9	Be able to use the relationships between functions of complex variables.
Iterations	10	Be able to perform iterations of a function of a complex variable

FURTHER PURE MATHEMATICS WITH TECHNOLOGY, FPT

Ref.	Notes	Notation	Exclusions
------	-------	----------	------------

FUNCTIONS OF COMPLEX VARIABLES

1	e.g. $\text{real}((x + yi)^3) = x^3 - 3xy^2$ To include polynomials, rational functions, $\sin z$, $\sinh z$, $\cos z$, $\cosh z$, e^z		
2	To include the representation of solutions on the Argand diagram.		
3	Students are expected to know that a polynomial of degree n has n complex roots.		Proof of the fundamental theorem of algebra
4	Students will be expected to solve a polynomial with complex coefficients using CAS.		
5			Tests for differentiability. The Cauchy-Riemann equations.
6	e.g. using indefinite integration to solve $f'(z) = \cos z$.		
7	Limits will be restricted to $\lim_{h \rightarrow 0} f((x + h) + iy)$ or $\lim_{h \rightarrow 0} f(x + i(y + h))$. CAS may be used.		
8			
9	The following may be used: $\sin(x + iy) = \sin x \cosh y + i \cos x \sinh y$ $\sinh(x + iy) = \sinh x \cos y + i \cosh x \sin y$ $\cos(x + iy) = \cos x \cosh y - i \sin x \sinh y$ $\cosh(x + iy) = \cosh x \cos y + i \sinh x \sin y$ $e^{x+iy} = e^x e^{iy}$ $= e^x \cos y + i e^x \sin y$ Students are expected to be able to express these relationships in terms of Maclaurin series.		
10	To include the geometrical representation.		

FURTHER PURE MATHEMATICS WITH TECHNOLOGY, FPT

Specification	Ref.	Competence Statements
---------------	------	-----------------------

NUMBER THEORY

The assessment of this topic will be based on the assumption that candidates have a suitable programming language.

Examination questions will feature programs that produce the solutions to problems in Number Theory. Candidates may be expected to write their own programs as well as understanding a program and suggesting limitations and refinements to it.

Programming	FPTT1	Be able to write programs to solve number theory problems.
	2	Be able to identify the limitations of a short program and suggest refinements to it.
Factorisation	3	Know the unique factorisation of natural numbers.
	4	Be able to solve problems using modular arithmetic.
	5	Know Fermat's little theorem.
Diophantine Equations	6	Be able to solve linear Diophantine equations and use solutions to solve related problems.
	7	Be able to find Pythagorean triples and use related equations.
	8	Be able to solve Pell's equation and use solutions to solve related problems.
	9	Be able to solve other Diophantine equations and use solutions to solve related problems.
Gaussian integers	10	Know the definition of Gaussian integers and be able to find and use Gaussian primes.

FURTHER PURE MATHEMATICS WITH TECHNOLOGY, FPT

Ref.	Notes	Notation	Exclusions
------	-------	----------	------------

NUMBER THEORY

FPTT1	IF, WHILE, FOR, LOOP, GOTO, local/global variables, inputting/outputting variables, basic lists/arrays (1D only). Problems will be taken from statements 3-10.		
2	Students will be expected to discuss, informally, the efficiency of a program and offer a small number of changes to it.		
3			Proof of the fundamental theorem of arithmetic
4		$16 \equiv 2 \pmod{7}$	
5	Use of the terms co-prime and GCD/HCF.		
6			
7	Related equations may include different indices, such as $x^2 + y^2 = z^3$.		
8			
9	All the required information will be given in the question.		
10			

7 Further Information and Training for Teachers

The specifications are supported by a complete package provided by MEI and OCR.

On-line Support

- Web-based resources covering all the units in this specification (www.mei.org.uk; www.ocr.org.uk).

Teaching Materials

- Textbooks, one for each unit in the specifications.
- Students' Handbook.

INSET and Teacher Support

- One-day INSET courses provided by both MEI and OCR.
- The MEI annual three-day conference.
- MEI branch meetings.
- Help from both MEI and OCR at the end of the telephone.
- Regular newsletters from MEI.

Examinations

- Specimen examination papers and mark schemes.
- Past examination papers and mark schemes.
- Examiners' reports.
- Practice papers for new units.

Coursework

- A bank of coursework resource materials.
- Exemplar marked coursework.
- Reports to Centres from coursework moderators.

Addresses

The MEI Office	OCR
Monckton House, Epsom Centre	1 Hills Road
White Horse Business Park	Cambridge
Trowbridge, Wilts. BA14 0XG	CB1 2EU

Appendix A: Mathematical Formulae

This appendix lists formulae that candidates are expected to remember and that may not be included in formulae booklets.

Beside each formula is the unit in which it is first encountered.

Quadratic Equations

$$ax^2 + bx + c = 0 \text{ has roots } \frac{-b \pm \sqrt{b^2 - 4ac}}{2a} \quad \text{C1}$$

Laws of Logarithms

$$\log_a x + \log_a y \equiv \log_a (xy)$$

$$\log_a x - \log_a y \equiv \log_a \left(\frac{x}{y} \right) \quad \text{C2}$$

$$k \log_a x \equiv \log_a (x^k)$$

Trigonometry

In the triangle ABC

$$\frac{a}{\sin A} = \frac{b}{\sin B} = \frac{c}{\sin C} \quad \text{C2}$$

$$\text{Area} = \frac{1}{2} ab \sin C \quad \text{C2}$$

$$\cos^2 A + \sin^2 A \equiv 1 \quad \text{C2}$$

$$\sec^2 A \equiv 1 + \tan^2 A \quad \text{C4}$$

$$\operatorname{cosec}^2 A \equiv 1 + \cot^2 A \quad \text{C4}$$

$$\sin 2A \equiv 2 \sin A \cos A \quad \text{C4}$$

$$\cos 2A \equiv \cos^2 A - \sin^2 A \quad \text{C4}$$

$$\tan 2A \equiv \frac{2 \tan A}{1 - \tan^2 A} \quad \text{C4}$$

Differentiation

Function	Derivative	
x^n	nx^{n-1}	C2
$\sin kx$	$k \cos kx$	C4
$\cos kx$	$-k \sin kx$	C4
e^{kx}	ke^{kx}	C3
$\ln x$	$\frac{1}{x}$	C3
$f(x) + g(x)$	$f'(x) + g'(x)$	C2
$f(x)g(x)$	$f'(x)g(x) + f(x)g'(x)$	C3
$f(g(x))$	$f'(g(x))g'(x)$	C3

Integration

Function	Integral	
x^n	$\frac{1}{n+1} x^{n+1} + c, n \neq -1$	C2
$\cos kx$	$\frac{1}{k} \sin kx + c$	C4
$\sin kx$	$-\frac{1}{k} \cos kx + c$	C4
e^{kx}	$\frac{1}{k} e^{kx} + c$	C3
$\frac{1}{x}$	$\ln x + c, x \neq 0$	C2
$f'(x) + g'(x)$	$f(x) + g(x) + c$	C2
$f'(g(x))g'(x)$	$f(g(x)) + c$	C3

Area

$$\text{Area under a curve} = \int_a^b y dx \quad (y \geq 0) \quad \text{C2}$$

Vectors

$$\begin{pmatrix} x \\ y \\ z \end{pmatrix} \cdot \begin{pmatrix} a \\ b \\ c \end{pmatrix} = xa + yb + zc \quad \text{C4}$$

Appendix B: Mathematical Notation

1 Set Notation

\in	is an element of
\notin	is not an element of
$\{x_1, x_2, \dots\}$	the set with elements x_1, x_2, \dots
$\{x : \dots\}$	the set of all x such that ...
$n(A)$	the number of elements in set A
\emptyset	the empty set
\mathcal{E}	the universal set
A'	the complement of the set A
\mathbb{N}	the set of natural numbers, $\{1, 2, 3, \dots\}$
\mathbb{Z}	the set of integers, $\{0, \pm 1, \pm 2, \pm 3, \dots\}$
\mathbb{Z}^+	the set of positive integers, $\{1, 2, 3, \dots\}$
\mathbb{Z}_n	the set of integers modulo n , $\{0, 1, 2, \dots, n-1\}$
\mathbb{Q}	the set of rational numbers, $\left\{\frac{p}{q} : p \in \mathbb{Z}, q \in \mathbb{Z}^+\right\}$
\mathbb{Q}^+	the set of positive rational numbers, $\{x \in \mathbb{Q} : x > 0\}$
\mathbb{Q}_0^+	set of positive rational numbers and zero, $\{x \in \mathbb{Q} : x \geq 0\}$
\mathbb{R}	the set of real numbers
\mathbb{R}^+	the set of positive real numbers, $\{x \in \mathbb{R} : x > 0\}$
\mathbb{R}_0^+	the set of positive real numbers and zero, $\{x \in \mathbb{R} : x \geq 0\}$
\mathbb{C}	the set of complex numbers
(x, y)	the ordered pair x, y
$A \times B$	the cartesian product of sets A and B , i.e. $A \times B = \{(a, b) : a \in A, b \in B\}$
\subseteq	is a subset of
\subset	is a proper subset of
\cup	union
\cap	intersection
$[a, b]$	the closed interval $\{x \in \mathbb{R} : a \leq x \leq b\}$

$[a, b)$	the interval $\{x \in \mathbb{R} : a \leq x < b\}$
$(a, b]$	the interval $\{x \in \mathbb{R} : a < x \leq b\}$
(a, b)	the open interval $\{x \in \mathbb{R} : a < x < b\}$
$y R x$	y is related to x by the relation R
$y \sim x$	y is equivalent to x , in the context of some equivalence relation

2 Miscellaneous Symbols

$=$	is equal to
\neq	is not equal to
\equiv	is identical to or is congruent to
\approx	is approximately equal to
\cong	is isomorphic to
\propto	is proportional to
$<$	is less than
\leq	is less than or equal to, is not greater than
$>$	is greater than
\geq	is greater than or equal to, is not less than
∞	infinity
$p \wedge q$	p and q
$p \vee q$	p or q (or both)
$\sim p$	not p
$p \Rightarrow q$	p implies q (if p then q)
$p \Leftarrow q$	p is implied by q (if q then p)
$p \Leftrightarrow q$	p implies and is implied by q (p is equivalent to q)
\exists	there exists
\forall	for all

3 Operations

$a + b$	a plus b
$a - b$	a minus b
$a \times b, ab, a.b$	a multiplied by b
$a \div b, \frac{a}{b}, a/b$	a divided by b

$\sum_{i=1}^n a_i$	$a_1 + a_2 + \dots + a_n$
$\prod_{i=1}^n a_i$	$a_1 \times a_2 \times \dots \times a_n$
\sqrt{a}	the positive square root of a
$ a $	the modulus of a
$n!$	n factorial
$\binom{n}{r}, {}^n C_r$	the binomial coefficient $\frac{n!}{r!(n-r)!}$ for $n \in \mathbb{Z}^+$ or $\frac{n(n-1)\dots(n-r+1)}{r!}$ for $n \in \mathbb{Q}$

4 Functions

$f(x)$	the value of the function f at x
$f : A \rightarrow B$	f is a function under which each element of set A has an image in set B
$f : x \mapsto y$	the function f maps the element x to the element y
f^{-1}	the inverse function of the function f
gf	the composite function of f and g which is defined by $gf(x) = g(f(x))$
$\lim_{x \rightarrow a} f(x)$	the limit of $f(x)$ as x tends to a
$\Delta x, \delta x$	an increment of x
$\frac{dy}{dx}$	the derivative of y with respect to x
$\frac{d^n y}{dx^n}$	the n th derivative of y with respect to x
$f'(x), f''(x), \dots, f^{(n)}(x)$	the first, second, ..., n th derivatives of $f(x)$ with respect to x
$\int y \, dx$	the indefinite integral of y with respect to x
$\int_a^b y \, dx$	the definite integral of y with respect to x between the limits $x = a$ and $x = b$
$\frac{\partial V}{\partial x}$	the partial derivative of V with respect to x
\dot{x}, \ddot{x}, \dots	the first, second, ... derivatives of x with respect to t

5 Exponential and Logarithmic Functions

e	base of natural logarithms
$e^x, \exp x$	exponential function of x
$\log_a x$	logarithm to the base a of x
$\ln x, \log_e x$	natural logarithm of x
$\lg x, \log_{10} x$	logarithm of x to base 10

6 Circular and Hyperbolic Functions

$\left. \begin{array}{l} \sin, \cos, \tan, \\ \operatorname{cosec}, \sec, \cot \end{array} \right\}$	the circular functions
$\left. \begin{array}{l} \arcsin, \arccos, \arctan, \\ \operatorname{arcosec}, \operatorname{arcsec}, \operatorname{arccot} \end{array} \right\}$	the inverse circular functions
$\left. \begin{array}{l} \sinh, \cosh, \tanh, \\ \operatorname{cosech}, \operatorname{sech}, \operatorname{coth} \end{array} \right\}$	the hyperbolic functions
$\left. \begin{array}{l} \operatorname{arcsinh}, \operatorname{arcosh}, \operatorname{arctanh}, \\ \operatorname{arcosech}, \operatorname{arcsech}, \operatorname{arcoth} \end{array} \right\}$	the inverse hyperbolic functions

7 Complex Numbers

i, j	square root of -1
z	a complex number, $z = x + jy = r(\cos \theta + j \sin \theta)$
$\operatorname{Re} z$	the real part of z , $\operatorname{Re} z = x$
$\operatorname{Im} z$	the imaginary part of z , $\operatorname{Im} z = y$
$ z $	the modulus of z , $ z = \sqrt{x^2 + y^2}$
$\arg z$	the argument of z , $\arg z = \theta$, $-\pi < \theta \leq \pi$
z^*	the complex conjugate of z , $x - jy$

8 Matrices

\mathbf{M}	a matrix \mathbf{M}
\mathbf{M}^{-1}	the inverse of the matrix \mathbf{M}
\mathbf{M}^T	the transpose of the matrix \mathbf{M}
$\det \mathbf{M}$ or $ \mathbf{M} $	the determinant of the square matrix \mathbf{M}

9 Vectors

\mathbf{a}	the vector \mathbf{a}
\overline{AB}	the vector represented in magnitude and direction by the directed line segment AB
$\hat{\mathbf{a}}$	a unit vector in the direction of \mathbf{a}
$\mathbf{i}, \mathbf{j}, \mathbf{k}$	unit vectors in the directions of the cartesian coordinate axes
$ \mathbf{a} , a$	the magnitude of \mathbf{a}
$ \overline{AB} , AB$	the magnitude of \overline{AB}
$\mathbf{a} \cdot \mathbf{b}$	the scalar product of \mathbf{a} and \mathbf{b}
$\mathbf{a} \times \mathbf{b}$	the vector product of \mathbf{a} and \mathbf{b}

10 Probability and Statistics

$A, B, C, \text{ etc.}$	events
$A \cup B$	union of the events A and B
$A \cap B$	intersection of the events A and B
$P(A)$	probability of the event A
A'	complement of the event A
$P(A B)$	probability of the event A conditional on the event B
$X, Y, R, \text{ etc.}$	random variables
$x, y, r, \text{ etc.}$	values of the random variables X, Y, R etc
x_1, x_2, \dots	observations
f_1, f_2, \dots	frequencies with which the observations x_1, x_2, \dots occur
$p(x)$	probability function $P(X = x)$ of the discrete random variable X
p_1, p_2, \dots	probabilities of the values x_1, x_2, \dots of the discrete random variable X
$f(x), g(x), \dots$	the value of the probability density function of a continuous random variable X
$F(x), G(x), \dots$	the value of the (cumulative) distribution function $P(X \leq x)$ of a continuous random variable X
$E(X)$	expectation of the random variable X
$E(g(X))$	expectation of $g(X)$
$\text{Var}(X)$	variance of the random variable X
$G(t)$	probability generating function for a random variable which takes the values $0, 1, 2, \dots$

$B(n, p)$	binomial distribution with parameters n and p
$N(\mu, \sigma^2)$	normal distribution with mean μ and variance σ^2
μ	population mean
σ^2	population variance
σ	population standard deviation
\bar{x}, m	sample mean
$s^2, \hat{\sigma}^2$	unbiased estimate of population variance from a sample, $s^2 = \frac{1}{n-1} \sum (x_i - \bar{x})^2$
ϕ	probability density function of the standardised normal variable with distribution $N(0, 1)$
Φ	corresponding cumulative distribution function
ρ	product moment correlation coefficient for a population
r	product moment correlation coefficient for a sample
$\text{Cov}(X, Y)$	covariance of X and Y

