

GATEWAY SCIENCE SUITE

# GCSE PHYSICS B

ACCREDITED SPECIFICATION

**J265**

VERSION 2

MAY 2012

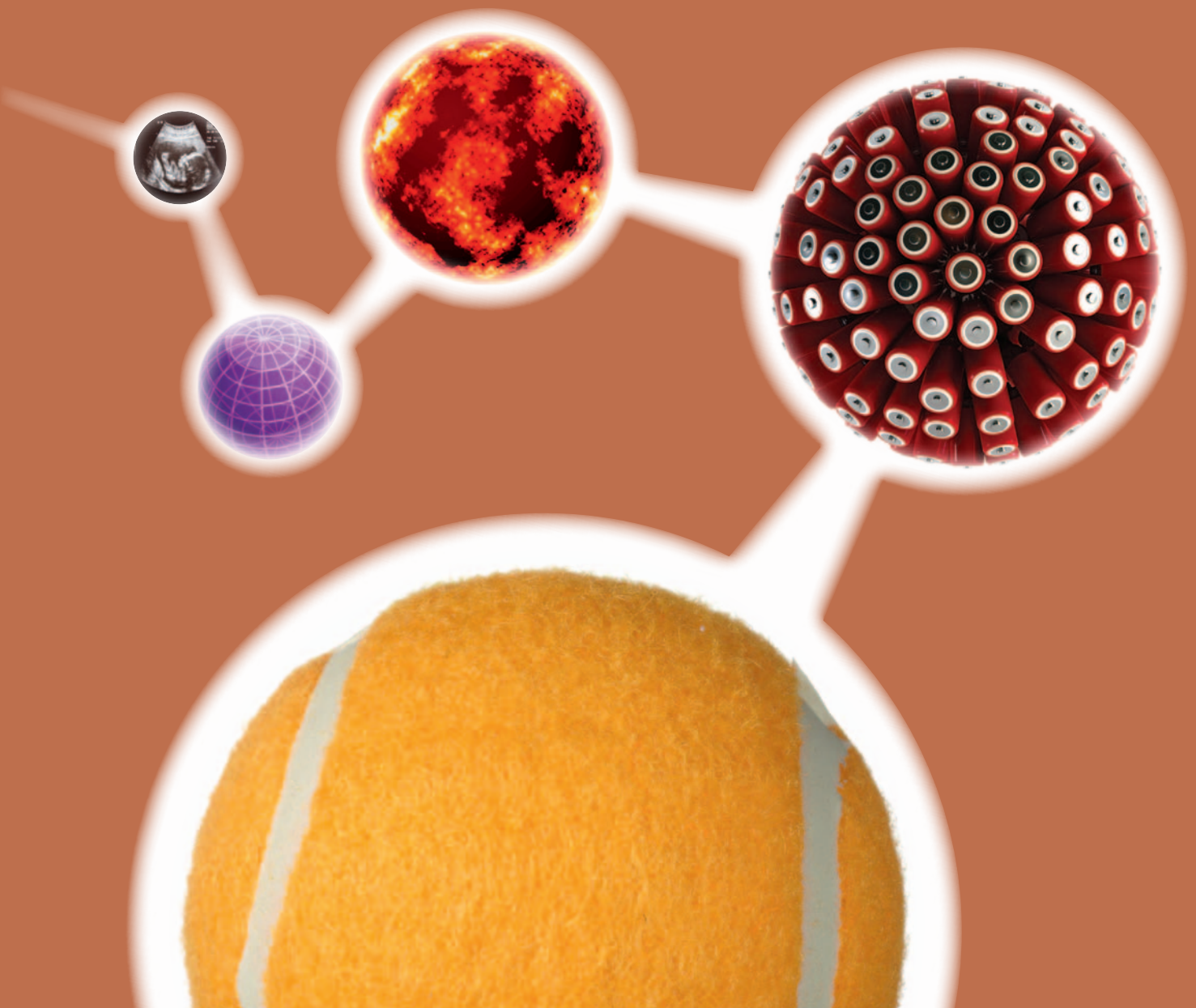

# WELCOME TO GCSE SCIENCES

THOUSANDS OF TEACHERS ALREADY UNLEASH THE JOY OF SCIENCE WITH OCR.

## A FEW GOOD REASONS TO WORK WITH OCR

- You can enjoy the **freedom and excitement** of teaching science qualifications which have been developed to help you inspire students of all abilities.
- We've built specifications **with you in mind**, using a clear and easy-to-understand format, making them straightforward for you to deliver.
- Our **clear and sensible assessment** approach means that exam papers and requirements are clearly presented and sensibly structured for you and your students.
- **Pathways for choice** – we have the broadest range of science qualifications and our GCSEs provide an ideal foundation for students to progress to more-advanced studies and science-related careers.
- **Working in partnership to support you** – together with teachers we've developed a range of practical help and support to save you time. We provide everything you need to teach our specifications with confidence and ensure your students get as much as possible from our qualifications.
- **A personal service** – as well as providing you with lots of support resources, we're also here to help you with specialist advice, guidance and support for those times when you simply need a more individual service.

### HERE'S HOW TO CONTACT US FOR SPECIALIST ADVICE:

By phone: 01223 553998

By email: [science@ocr.org.uk](mailto:science@ocr.org.uk)

By online: <http://answers.ocr.org.uk>

By fax: 01223 552627

By post: Customer Contact Centre,  
OCR, Progress House, Westwood  
Business Park, Coventry  
CV4 8JQ

### DON'T FORGET

– you can download a copy of this specification and all our support materials at [www.ocr.org.uk/gcse2012](http://www.ocr.org.uk/gcse2012)

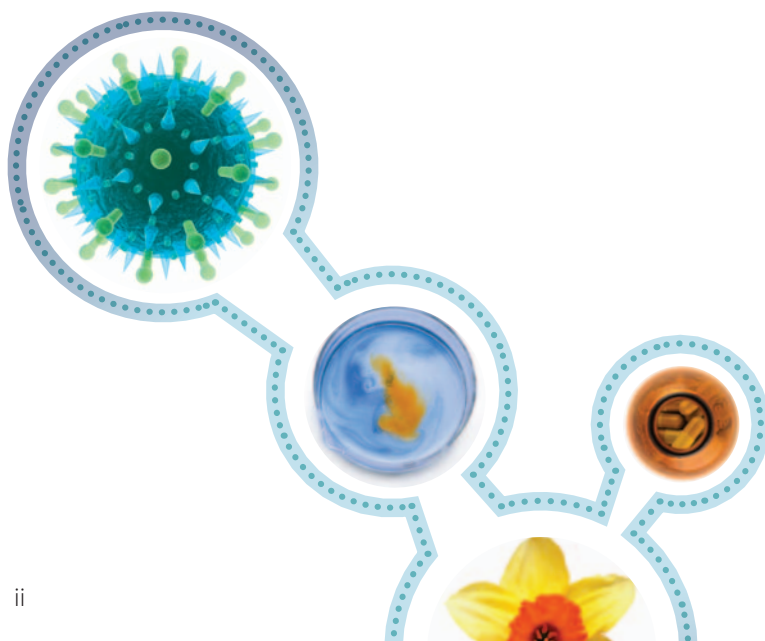

# SUPPORTING YOU ALL THE WAY

Our aim is to help you at every stage and we work in close consultation with teachers and other experts to provide a practical package of high quality resources and support.

Our support materials are designed to save you time while you prepare for and teach our new specifications. In response to what you have told us we are offering detailed guidance on key topics, controlled assessment and curriculum planning.

## Our essential FREE support includes:

### Materials

- Specimen assessment materials and mark schemes
- Guide to controlled assessment
- Sample controlled assessment material
- Exemplar candidate work
- Teacher's handbook
- Sample schemes of work and lesson plans
- Guide to curriculum planning
- Frequently asked questions
- Past papers.

You can access all of our support at:  
[www.gcse-science.com](http://www.gcse-science.com)

### Training

#### Our GCSE Science Get Started events:

- include useful information about our specifications direct from the experts
- are designed to assist you in preparing to teach
- provide you with an opportunity to speak face-to-face with our team.

We're also developing online support and training for those unable to get away from school.

Go to [www.ocr.org.uk/science2011/training](http://www.ocr.org.uk/science2011/training) for full details and to book your place.

### Science Community

Join our social network at [www.social.ocr.org.uk](http://www.social.ocr.org.uk) where you can start discussions, ask questions and upload resources.

### Services

- **Answers @ OCR** – a web based service where you can browse hot topics, FAQs or e-mail us with your questions. Available June 2011. Visit <http://answers.ocr.org.uk>
- **Active Results** – service to help you review the performance of individual candidates or a whole school, with a breakdown of results by question and topic.
- **Local cluster support networks** – supported by OCR, you can join our local clusters of centres who offer each other mutual support.

### Endorsed publisher partner materials

We're working closely with our publisher partner Collins Education to ensure effective delivery of endorsed materials when you need them.

Find out more at:

[www.collinseducation.com/newgcscscience](http://www.collinseducation.com/newgcscscience)

## WHAT TO DO NEXT

**1) Sign up to teach** – let us know you will be teaching this specification to ensure you receive all the support and examination materials you need. Simply complete the online form at [www.ocr.org.uk/science/signup](http://www.ocr.org.uk/science/signup)

**2) Become an approved OCR centre** – if your centre is completely new to OCR and has not previously used us for any examinations, visit [www.ocr.org.uk/centreapproval](http://www.ocr.org.uk/centreapproval) to become an approved OCR centre.

# GATEWAY SCIENCE SUITE

## Science in Action

Understand the questions that science can answer. Unpick the scientific concepts and investigate their familiar applications through active learning.

Our Gateway Science Suite gives you and your students:

- an emphasis on getting more involved in the learning process through a variety of interesting activities and experiences, identifying links to scientific ideas and their implications for society
- the opportunity to develop scientific explanations and theories.

### KEY FEATURES

- **Flexible assessments**, which can be carried out at the end of the course or at times during the course when students' understanding is at its best.
- **Unique assessment approach** – more straightforward to manage and puts you in greater control, while making it easier to manage resits (for example 40% weighted unit resit of one unit rather than two and meets the terminal rule).
- **Practical work** is at the heart of the Gateway Science Suite.

### POSSIBLE GCSE COMBINATIONS

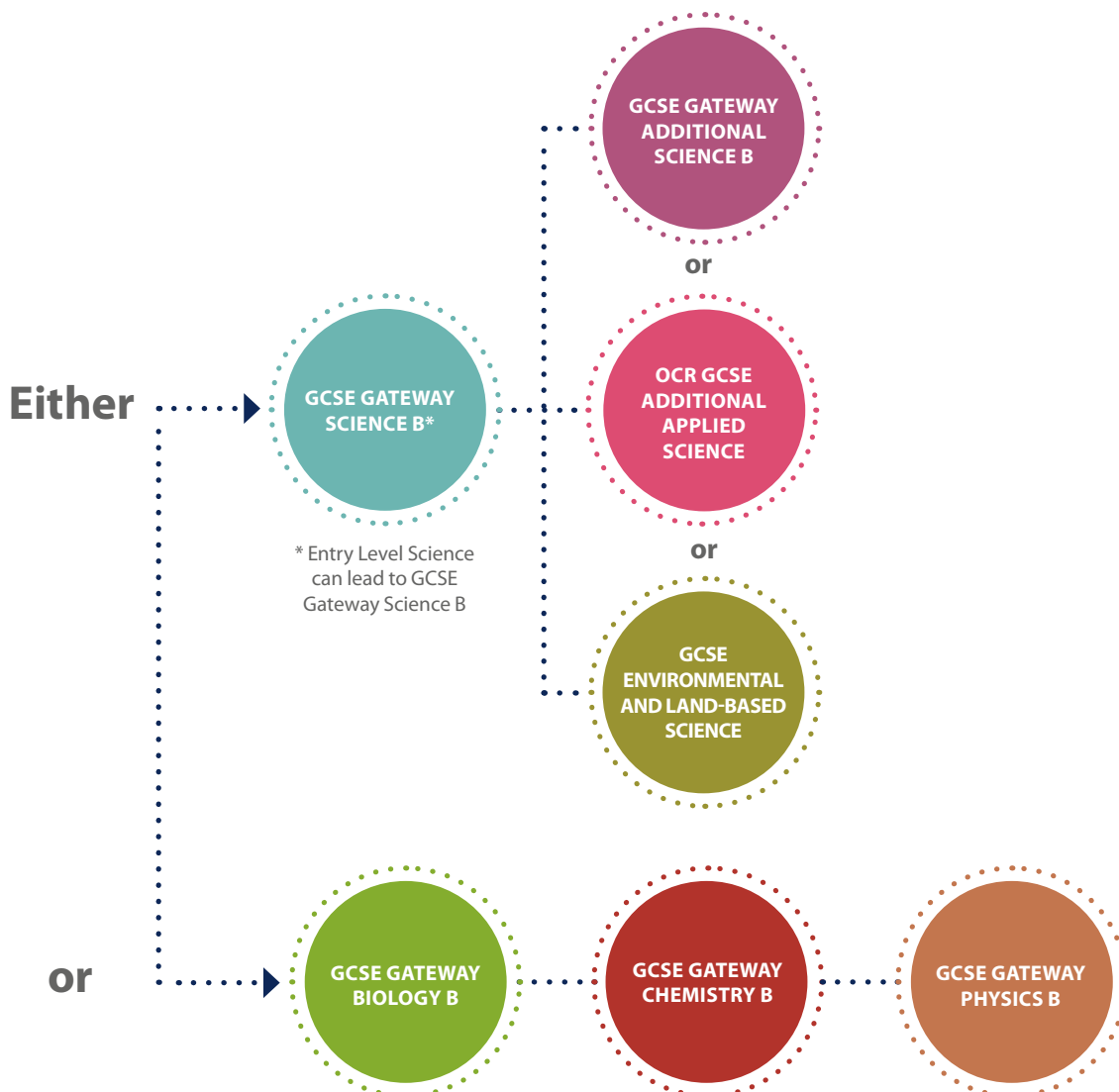

# GCSE PHYSICS B

## KEY FEATURES

GCSE Physics B aims to give students the opportunity to:

- develop their interest in, and enthusiasm for, physics
- develop a critical approach to scientific evidence and methods
- acquire and apply skills, knowledge and understanding of how science works and its essential role in society
- acquire scientific skills, knowledge and understanding necessary for progression to further learning.

GCSE Physics B provides distinctive and relevant experience for students who wish to progress to Level 3 qualifications.

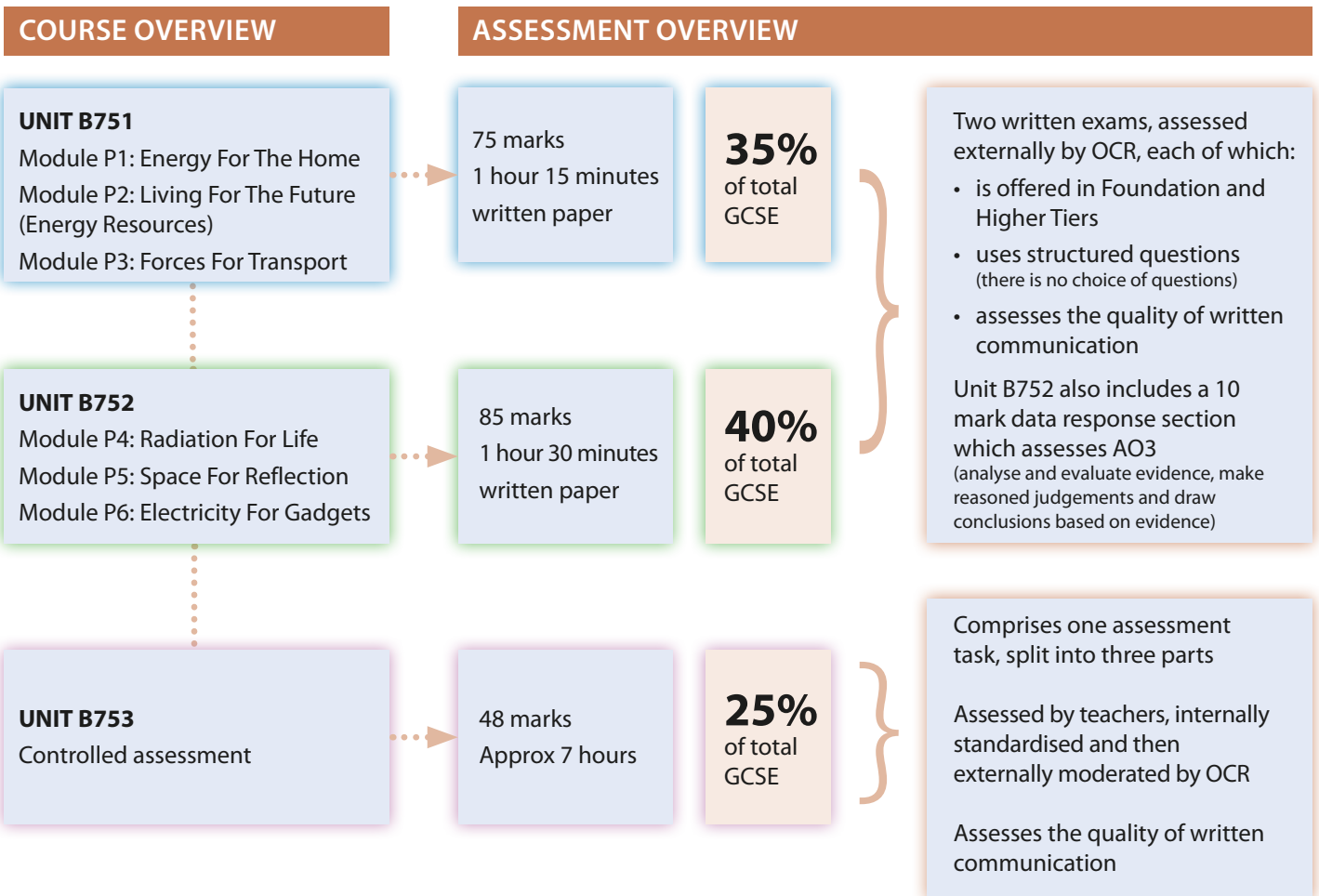
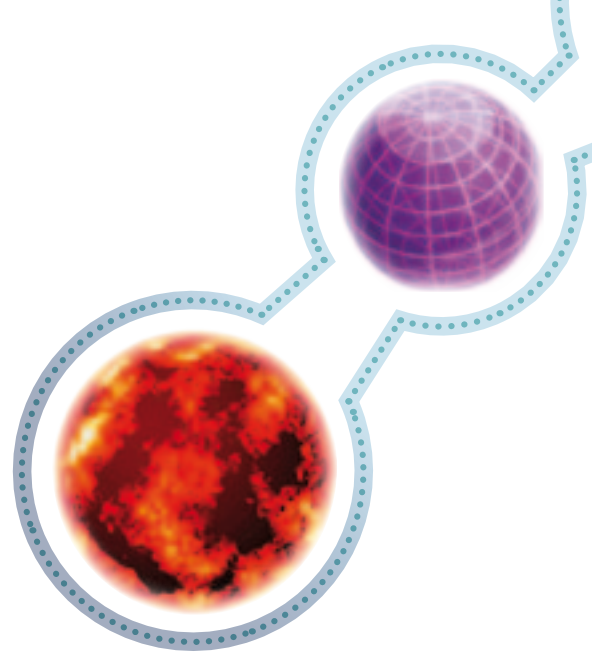



# PROGRESSION PATHWAYS IN SCIENCE

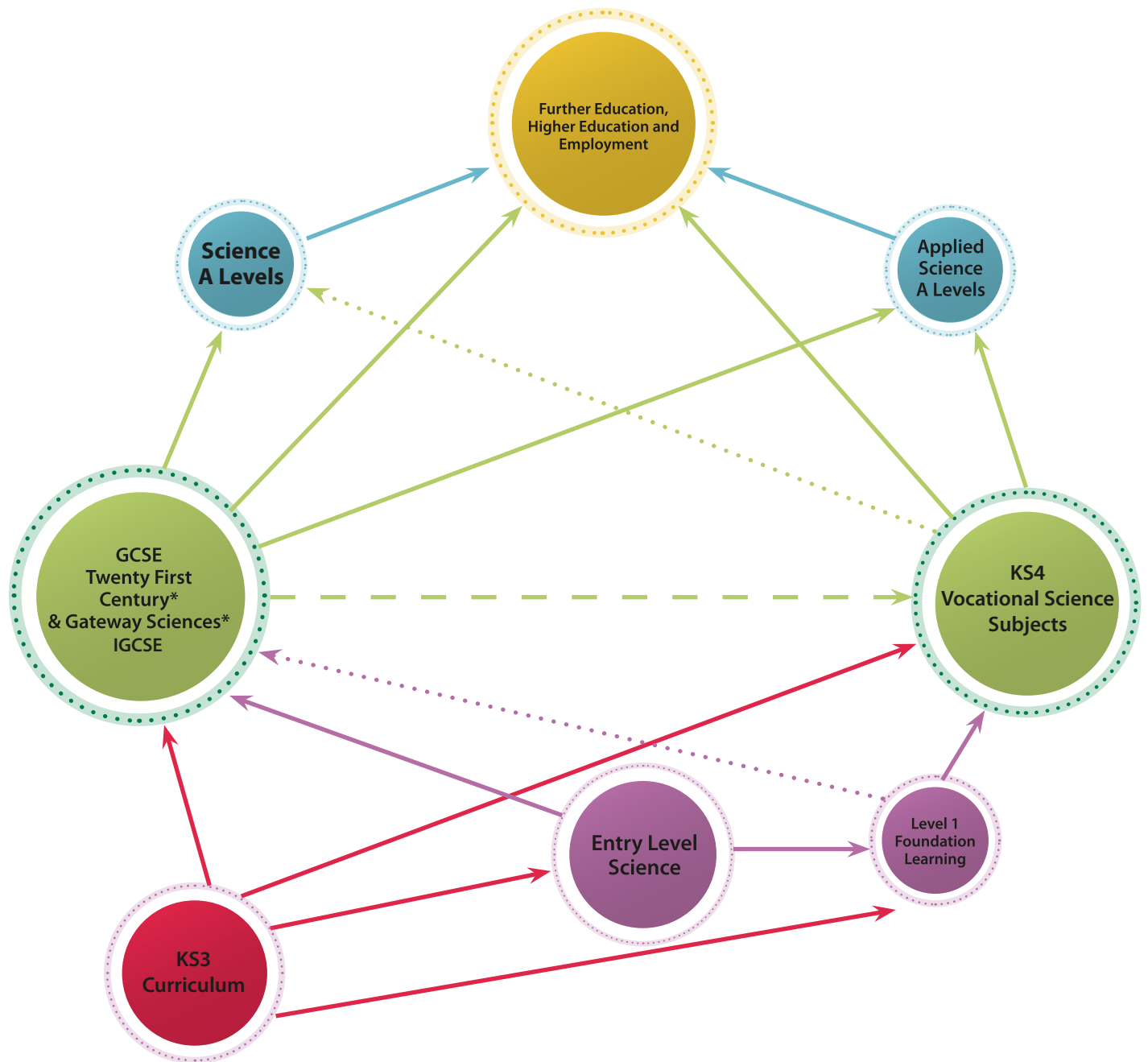

\* Offered as Science, Additional Science, Biology, Chemistry and Physics.



The specification has been updated. Changes can be found to the NPN transistor diagram on page 99.

# Contents

<b>1</b>	<b>Introduction to the Gateway Suite</b>	<b>5</b>
<b>2</b>	<b>Introduction to GCSE Physics B</b>	<b>6</b>
2.1	Overview of GCSE Physics B	6
2.2	What is new in GCSE Physics B?	7
2.3	Guided learning hours	7
2.4	Aims and learning outcomes	8
2.5	Prior learning	8
<b>3</b>	<b>Content of GCSE Physics B</b>	<b>10</b>
3.1	Summary of content	10
3.2	Layout of teaching items	11
3.3	Fundamental Scientific Processes	12
3.4	Module P1: <i>Energy For The Home</i>	14
3.5	Module P2: <i>Living For The Future (Energy Resources)</i>	30
3.6	Module P3: <i>Forces For Transport</i>	46
3.7	Module P4: <i>Radiation For Life</i>	62
3.8	Module P5: <i>Space For Reflection</i>	78
3.9	Module P6: <i>Electricity For Gadgets</i>	94
<b>4</b>	<b>Assessment of GCSE Physics B</b>	<b>110</b>
4.1	Overview of the assessment in GCSE Physics B	110
4.2	Tiers	111
4.3	Assessment objectives (AOs)	111
4.4	Grading and awarding grades	112
4.5	Grade descriptions	113
4.6	Quality of written communication	114
<b>5</b>	<b>Controlled assessment in GCSE Physics B</b>	<b>115</b>
5.1	Controlled assessment tasks	115
5.2	Nature of controlled assessment tasks	115
5.3	Planning and managing controlled assessment	116
5.4	Marking and moderating controlled assessment	119
5.5	Internal standardisation	126
5.6	Submitting marks and authentication	126
5.7	Submitting samples of candidate work	126
5.8	External moderation	127



# Contents

<b>6</b>	<b>Support for GCSE Physics B</b>	<b>128</b>
6.1	Free resources available from the OCR website	128
6.2	Other resources	128
6.3	Training	130
6.4	OCR support services	130
<b>7</b>	<b>Equality and Inclusion in GCSE Physics B</b>	<b>131</b>
7.1	Equality Act information relating to GCSE Physics B	131
7.2	Arrangements for candidates with particular requirements (including Special Consideration)	131
<b>8</b>	<b>Administration of GCSE Physics B</b>	<b>132</b>
8.1	Availability of assessment from 2014	132
8.2	Certification rules	132
8.3	Rules for re-taking a qualification	132
8.4	Making entries	133
8.5	Enquiries about results	134
8.6	Prohibited qualifications and classification code	134
<b>9</b>	<b>Other information about GCSE Physics B</b>	<b>135</b>
9.1	Overlap with other qualifications	135
9.2	Progression from this qualification	135
9.3	Avoidance of bias	135
9.4	Regulatory requirements	135
9.5	Language	135
9.6	Spiritual, moral, ethical, social, legislative, economic and cultural issues	136
9.7	Sustainable development, health and safety considerations and European developments, consistent with international agreements	136
9.8	Key Skills	137
9.9	ICT	138
9.10	Citizenship	138
<b>Appendix A: Guidance for the production of electronic controlled assessment</b>		<b>139</b>
<b>Appendix B: Mathematics skills for GCSE science qualifications</b>		<b>141</b>
<b>Appendix C: Physical quantities and units</b>		<b>142</b>
<b>Appendix D: Health and safety</b>		<b>143</b>
<b>Appendix E: Electrical symbols</b>		<b>144</b>



The Gateway Science Suite comprises five specifications which share a common approach, utilise common material, use a similar style of examination questions and have a common approach to skills assessment.

The qualifications available as part of this suite are:

- GCSE Science
- GCSE Additional Science
- GCSE Biology
- GCSE Chemistry
- GCSE Physics.

The suite emphasises explanations, theories and modelling in science along with the implications of science for society. Strong emphasis is placed on the active involvement of candidates in the learning process and each specification encourages a wide range of teaching and learning activities.

The suite is supported by resources published by Collins.

OCR also offers a specification in GCSE Additional Applied Science which may be taken as an alternative to GCSE Additional Science.

**2.1 Overview of GCSE Physics B****Unit B751** *Physics modules P1, P2, P3*

This is a tiered unit offered in Foundation and Higher Tiers.

Written paper  
1 hour 15 mins – 75 marks  
35% of the qualification

Question paper comprises structured questions.  
Candidates answer all questions.

+

**Unit B752** *Physics modules P4, P5, P6*

This is a tiered unit offered in Foundation and Higher Tiers.

Written paper  
1 hour 30 mins – 85 marks  
40% of the qualification

Question paper comprises structured questions and analysis of data.  
Candidates answer all questions.

+

**Unit B753** *Physics controlled assessment*

This unit is not tiered.

Controlled assessment  
48 marks  
25% of the qualification

## 2.2 What is new in GCSE Physics B?

	What stays the same?	What changes?
<b>Structure</b>	<ul style="list-style-type: none"> <li>• Three units, comprising two externally assessed units and one internally assessed unit.</li> <li>• Externally assessed units are tiered – Foundation and Higher tier.</li> <li>• Unit weightings – Unit B751 still 35%, Unit B752 still 40%.</li> <li>• Controlled assessment still 25% weighting.</li> </ul>	<ul style="list-style-type: none"> <li>• The course will be assessed as linear.</li> </ul>
<b>Content</b>	<ul style="list-style-type: none"> <li>• Content is divided into 6 modules, P1 – P6.</li> </ul>	
<b>Assessment</b>	<ul style="list-style-type: none"> <li>• Papers include structured questions and objective questions.</li> <li>• The internally assessed unit is based on a single investigative task divided into three parts.</li> <li>• There will be a choice of controlled assessment tasks, set by OCR, and valid for entry in one year only.</li> <li>• Unit B751 paper is 1 hour 15 mins long, with a total of 75 marks.</li> <li>• Unit B752 paper is 1 hour 30 mins long, with a total of 85 marks including a 10 mark analysis of evidence section.</li> <li>• How Science Works will be assessed in all units.</li> <li>• Quality of written communication will be assessed in all units.</li> </ul>	<ul style="list-style-type: none"> <li>• New 100% assessment rules apply to science GCSEs. All units, including written papers, available for assessment in June series only.</li> </ul>

## 2.3 Guided learning hours

GCSE Physics B requires 120–140 guided learning hours in total.

## 2.4 Aims and learning outcomes

GCSE specifications in Physics should encourage learners to be inspired, motivated and challenged by following a broad, coherent, practical, satisfying and worthwhile course of study. They should encourage learners to develop their curiosity about the physical world, and provide insight into, and experience of, how science works. They should enable learners to engage with physics in their everyday lives and to make informed choices about further study in physics and related disciplines and about career choices.

The aims of this specification are to enable candidates to:

- develop their knowledge and understanding of physics
- develop their understanding of the effects of physics and its applications on society
- develop an understanding of the importance of scale in physics
- develop and apply their knowledge and understanding of the nature of science and of the scientific process
- develop their understanding of the relationships between hypotheses, evidence, theories and explanations
- develop their awareness of risk and the ability to assess potential risk in the context of potential benefits
- develop and apply their observational, practical, modelling, enquiry and problem-solving skills and understanding in the laboratory, and in other learning environments
- develop their ability to evaluate claims based on science through critical analysis of the methodology, evidence and conclusions both qualitatively and quantitatively
- develop their skills in communication, mathematics and the use of technology in scientific contexts.

## 2.5 Prior learning

Candidates entering this course should have achieved a general educational level equivalent to National Curriculum Level 3, or an Entry 3 at Entry Level within the National Qualifications Framework.





# Content of GCSE Physics B

3

## 3.1 Summary of content

The specification content is presented as six modules which are listed below. Within each module the content is shown as eight items (e.g. P1a, P1b, P1c, P1d, P1e, P1f, P1g, P1h). Thus, the specification content contains a total of 48 teaching items. Each item requires approximately 2½ hours teaching time.

Module P1: <i>Energy For The Home</i>	Module P2: <i>Living For The Future (Energy Resources)</i>	Module P3: <i>Forces For Transport</i>
a Heating houses	a Collecting energy from the Sun	a Speed
b Keeping homes warm	b Generating electricity	b Changing speed
c A spectrum of waves	c Global warming	c Forces and motion
d Light and lasers	d Fuels for power	d Work and power
e Cooking and communicating using waves	e Nuclear radiations	e Energy on the move
f Data transmission	f Exploring our Solar System	f Crumple zones
g Wireless signals	g Threats to Earth	g Falling safely
h Stable Earth	h The Big Bang	h The energy of games and theme rides
Module P4: <i>Radiation For Life</i>	Module P5: <i>Space For Reflection</i>	Module P6: <i>Electricity For Gadgets</i>
a Sparks	a Satellites, gravity and circular motion	a Resisting
b Uses of electrostatics	b Vectors and equations of motion	b Sharing
c Safe electricals	c Projectile motion	c It's logical
d Ultrasound	d Action and reaction	d Even more logical
e What is radioactivity?	e Satellite communication	e Motoring
f Uses of radioisotopes	f Nature of waves	f Generating
g Treatment	g Refraction of waves	g Transforming
h Fission and fusion	h Optics	h Charging

### 3.2 Layout of teaching items

The detailed specification content is displayed in tabular format, designed to provide a ‘teacher-friendly’ approach to the content. This allows teachers to see, at a glance, links between the development of skills and understanding of how science works, and the knowledge and understanding of different science ideas and contexts. The layout of each module follows the outline given below.

Module Code and Title (e.g. Understanding Organisms)		Module Code and Title	
Item code and title: e.g. B1a: Fitness and Health		Item code and title: e.g. B1a: Fitness and Health	
<b>Summary:</b> A short overview of the item, including the skills, knowledge and understanding of how science works that may be covered within this item.		<b>Links to other items:</b> Opportunities for linking ideas across modules within the Gateway suite of sciences.	
Suggested practical and research activities to select from	Assessable learning outcomes Foundation Tier only: low demand	Assessable learning outcomes both tiers: standard demand	Assessable learning outcomes Higher Tier only: high demand
Ideas for teaching activities related to the item, which will integrate the skills, knowledge and understanding of how science works into a teaching scheme.  Teachers may choose from these suggestions or develop other comparable activities.	Learning outcomes that will only be assessed in the Foundation Tier paper.  The use of bullet points provides guidance on: <ul style="list-style-type: none"> <li>• depth</li> <li>• context</li> <li>• exemplification.</li> </ul>	Learning outcomes that can be assessed on either the Foundation Tier or Higher Tier question papers.  The use of bullet points provides guidance on: <ul style="list-style-type: none"> <li>• depth</li> <li>• context</li> <li>• exemplification.</li> </ul>	Learning outcomes that will only be assessed in the Higher Tier paper.  The use of bullet points provides guidance on: <ul style="list-style-type: none"> <li>• depth</li> <li>• context</li> <li>• exemplification.</li> </ul>

It may be necessary to teach the content of the Foundation Tier only column to provide the underpinning knowledge required by Higher Tier candidates.

Candidates who are following this specification should have underpinning knowledge of physics through familiarity with the physics content of the Key Stage 3 programme of study within the National Curriculum.

### 3.3 Fundamental Scientific Processes

#### Fundamental Scientific Processes

**Item Sa:** How Science Works

**Summary:** In addition to knowledge of the scientific explanations that are detailed in sections 3.4 – 3.9 below, candidates require an understanding of the fundamental scientific processes that underpin these explanations.

Links to other items	Assessable learning outcomes Foundation Tier only: low demand
<p>P1a, P1b, P1c, P1d, P1e, P2a, P2c, P2d, P2f, P3b, P3g, P3h, P4d, P4e, P4h, P5c, P5d, P5f, P5g, P5h, P6a, P6b, P6e, P6g, P6h</p> <p>P1h P2a, P2c, P2g, P2h, P4h</p> <p>P1c, P1h, P2c, P2g, P2h, P4h</p> <p>P1c, P2h, P4h, P5a, P5f</p> <p>P1e, P2c, P2h, P4h</p>	<p>Describe a simple scientific idea using a simple model.</p> <p>Identify two different scientific views or explanations of scientific data.</p> <p>Recall that scientific explanations (hypotheses) are:</p> <ul style="list-style-type: none"> <li>• used to explain observations</li> <li>• tested by collecting data/evidence.</li> </ul> <p>Describe examples of how scientists use a scientific idea to explain experimental observations or results.</p> <p>Recognise that scientific explanations are provisional but more convincing when there is more evidence to support them.</p>
<p>P1e, P1h, P2a, P2c, P2d, P2h, P4h</p> <p>P1f, P1h, P2a, P2b, P2c, P2e, P2g, P3c, P3e, P3f, P4b, P4c, P4d, P4e, P4g, P4h, P5a, P5e, P5g, P5h, P6c, P6d, P6f, P6g</p> <p>P1e, P1h, P2c, P2e, P3c, P3e, P3f, P4a, P4b, P4c, P4d, P4e, P4f, P4g, P4h, P6g</p>	<p>Identify different views that might be held regarding a given scientific or technological development.</p> <p>Identify how a scientific or technological development could affect different groups of people or the environment.</p> <p>Describe risks from new scientific or technological advances.</p>
<p>P1b, P1e, P1h, P2c, P2e, P3f, P4f, P4h</p> <p>P1e, P1h, P2c, P2h, P3f, P4f, P4h</p>	<p>Distinguish between claims/opinions and scientific evidence in sources.</p> <p>Recognise the importance of the peer review process in which scientists check each other's work.</p>
<p>P1a, P1b, P1g, P2b, P2c, P3a, P3b, P3c, P3d, P3e, P3h, P4c P4e, P5b, P5h, P6a, P6b, P6h</p> <p>P1e, P1h, P2c, P2h, P3f, P4g, P4h</p>	<p>Present data as tables, pie charts or line graphs identify trends in the data, and process data using simple statistical methods such as calculating a mean.</p> <p>Explain how a conclusion is based on the scientific evidence which has been collected.</p>

### Fundamental Scientific Processes

**Summary (cont.):** Studying these processes will provide candidates with an understanding of:

- how scientific explanations have been developed,
- their limitations, and
- how they may impact on individuals and society.

Assessable learning outcomes both tiers: standard demand	Assessable learning outcomes Higher Tier only: high demand
<p>Explain a scientific process, using ideas or models.</p> <p>Describe (without comparing) the scientific evidence that supports or refutes opposing scientific explanations.</p> <p>Explain how a scientific idea has changed as new evidence has been found.</p> <p>Describe examples of how scientists plan a series of investigations/make a series of observations in order to develop new scientific explanations.</p> <p>Recognise that scientific explanations are provisional because they only explain the current evidence and that some evidence/observations cannot yet be explained.</p>	<p>Explain a complex scientific process, using abstract ideas or models.</p> <p>Evaluate and critically compare opposing views, justifying why one scientific explanation is preferred to another.</p> <p>Identify the stages in the development of a scientific theory in terms of the way the evidence base has developed over time alongside the development of new ways of interpreting this evidence.</p> <p>Understand that unexpected observations or results can lead to new developments in the understanding of science.</p> <p>Recognise that confidence increases in provisional scientific explanations if observations match predictions, but this does not prove the explanation is correct.</p>
<p>Explain how the application of science and technology depends on economic, social and cultural factors.</p> <p>Identify some arguments for and against a scientific or technological development, in terms of its impact on different groups of people or the environment.</p> <p>Suggest ways of limiting risks and recognise the benefits of activities that have a known risk.</p>	<p>Describe the ways in which the values of society have influenced the development of science and technology.</p> <p>Evaluate the application of science and technology, recognising the need to consider what society considers right or wrong, and the idea that the best decision will have the best outcome for the majority of the people involved.</p> <p>Analyse personal and social choices in terms of a balance of risk and benefit.</p>
<p>Evaluate a claim/opinion in terms of its link to scientific evidence.</p> <p>Explain how publishing results through scientific conferences and publications enables results to be replicated and further evidence to be collected.</p>	<p>Evaluate critically the quality of scientific information or a range of views, from a variety of different sources, in terms of shortcomings in the explanation, misrepresentation or lack of balance.</p> <p>Explain the value of using teams of scientists to investigate scientific problems.</p>
<p>Choose the most appropriate format for presenting data, and process data using mathematical techniques such as statistical methods or calculating the gradients of graphs.</p> <p>Determine the level of confidence for a conclusion based on scientific evidence and describe how further predictions can lead to more evidence being obtained.</p>	<p>Identify complex relationships between variables, including inverse relationships, using several mathematical steps.</p> <p>Use range bars and understand their significance for data sets.</p> <p>Identify and critically analyse conflicting evidence, or weaknesses in the data, which lead to different interpretations, and explain what further data would help to make the conclusion more secure.</p>

### 3.4 Module P1: Energy For The Home

#### Module P1: Energy For The Home

##### Item P1a: Heating houses

**Summary:** When a body is heated, it gets hotter. A common misconception is that heat and temperature are the same thing. This item develops ideas to show that heat and temperature are different and that heat gain or loss does not always result in a temperature rise but can bring about a change of state. Because of a high specific heat capacity water needs lots of energy to increase its temperature. Because of this it also stores lots of energy and so is useful for transporting and transferring energy around homes.

Suggested practical and research activities to select from	Assessable learning outcomes Foundation Tier only: low demand
<p>Carry out an experiment to measure the fall in temperature of hot water.</p> <p>Carry out an experiment to measure the increase in temperature of water as it is heated.</p> <p>Examine thermograms to see where hot spots occur.</p>	<p>Understand that for warm bodies the rate of cooling depends on the temperature difference compared to the surroundings.</p> <p>Understand that temperature is represented by colour in a thermogram.</p>
<p>Carry out an experiment to measure the energy required to change the temperature of different bodies by different amounts.</p>	<p>Recall that heat is a measurement of energy and is measured in Joules (J).</p> <p>Describe how the energy needed to change the temperature of a body depends on:</p> <ul style="list-style-type: none"> <li>• mass</li> <li>• the material from which it is made</li> <li>• the temperature change.</li> </ul> <p>Describe an experiment to measure the energy required to change the temperature of a body.</p>
<p>Show that energy is needed to change state by placing a small piece of chocolate on the tongue and allowing it to melt.</p> <p>Carry out an experiment holding a lump of ice to explain why the ice melts and why the hand holding it gets cold.</p> <p>Carry out an experiment or use a computer simulation to plot a cooling curve for stearic acid as it cools.</p>	<p>Interpret data which shows that there is no temperature change when materials are:</p> <ul style="list-style-type: none"> <li>• boiling</li> <li>• melting or freezing.</li> </ul>

## Module P1: Energy For The Home

### Item P1a: Heating houses

**Links to other items:** P1b: Keeping homes warm

Assessable learning outcomes both tiers: standard demand	Assessable learning outcomes Higher Tier only: high demand
<p>Recognise, and understand the consequences of, the direction of energy flow between bodies of different temperatures.</p> <p>Interpret data on rate of cooling.</p> <p>Explain how temperatures can be represented by a range of colours in a thermogram:</p> <ul style="list-style-type: none"> <li>• hottest parts: white/yellow/red</li> <li>• coldest parts: black/dark blue/purple.</li> </ul>	<p>Describe temperature as a measurement of hotness on an arbitrary or chosen scale.</p> <p>Understand that temperature is a measurement of the average kinetic energy of particles.</p>
<p>Understand qualitatively and quantitatively the concept of the specific heat capacity of a material.</p> <p>Use the equation:</p> $\text{energy} = \text{mass} \times \frac{\text{specific heat}}{\text{capacity}} \times \text{temperature change}$	<p>Describe heat as a measurement of energy on an absolute scale.</p> <p>Use the equation, including a change of subject:</p> $\text{energy} = \text{mass} \times \frac{\text{specific heat}}{\text{capacity}} \times \text{temperature change}$ <p>An initial calculation of temperature change may be required.</p>
<p>Understand qualitatively and quantitatively the concept of the specific latent heat of a material.</p> <p>Use the equation:</p> $\text{energy} = \text{mass} \times \text{specific latent heat}$ <p>Describe how, even though energy is still being transferred, there is no temperature change when materials are:</p> <ul style="list-style-type: none"> <li>• boiling</li> <li>• melting or freezing.</li> </ul>	<p>Use the equation, including a change of subject:</p> $\text{energy} = \text{mass} \times \text{specific latent heat}$ <p>Explain why the temperature does not change during a change of state.</p>

## Module P1: Energy For The Home

### Item P1b: Keeping homes warm

**Summary:** The term insulation is used in the wider context of energy saving techniques in the home. This item develops ideas about the mechanisms of energy transfer by conduction, convection and radiation and the role they play in heat loss from homes. A poorly insulated home means that heat is being lost to the outside environment and more energy is needed to keep the home warm. Not only are energy resources being wasted but the homeowner is also paying for energy that is lost to the outside environment. This item develops ideas about using energy efficiently and reducing energy losses from homes.

Suggested practical and research activities to select from	Assessable learning outcomes Foundation Tier only: low demand
<p>Use a data logger or other apparatus to carry out an experiment to test the relative performance of various insulating materials.</p> <p>Use a data logger or other apparatus to carry out an experiment to test the transfer of energy through models (e.g. test tubes or beakers) of single, double and triple glazed windows.</p> <p>Use a data logger or other apparatus to carry out an experiment to test the reflection of energy from a silvered surface.</p> <p>Use a data logger or other apparatus to carry out an experiment to test the absorption of energy by a blackened dull surface.</p> <p>Perform or watch demonstration experiments to show convection currents in air and water.</p>	<p>Explain why trapped air in a material is a very good insulator.</p> <p>Recall that infrared radiation is:</p> <ul style="list-style-type: none"> <li>• reflected from a shiny surface</li> <li>• absorbed by a dull or rough surface.</li> </ul> <p>Understand how absorption and reflection of infrared radiation can be applied in everyday situations.</p>
<p>Examine thermograms showing where energy is lost from poorly insulated houses and from well insulated houses.</p> <p>Examine data showing percentage of energy lost from different areas of a poorly insulated house and from a well insulated house.</p> <p>Survey of fuel costs in the local area.</p> <p>Survey to compare the effectiveness of different building materials using information from the internet and builders' merchants.</p> <p>Use information, either in paper form or from websites including from local authorities and government, to compare costs of energy saving measures.</p> <p>Make a brochure or PowerPoint presentation to convince people to invest in energy saving measures.</p>	<p>Describe everyday examples of energy saving methods in the home.</p> <p>Explain how the property that air is a very good insulator is used to keep homes warm:</p> <ul style="list-style-type: none"> <li>• fibreglass, mineral or rock wool in loft insulation</li> <li>• double glazing in windows</li> <li>• insulation foam or fibreglass in cavity walls</li> <li>• curtains at windows.</li> </ul> <p>Describe other energy saving measures:</p> <ul style="list-style-type: none"> <li>• reflective foil in or on walls</li> <li>• draught-proofing.</li> </ul> <p>Use the equation:</p> $\text{efficiency} = \frac{\text{useful energy output (}\times 100\%)}{\text{total energy input}}$ <p>given the useful energy output and the total energy input; efficiency can be expressed in ratio or percentage terms.</p>



## Module P1: Energy For The Home

**Item P1b:** Keeping homes warm

**Links to other items:** P1a: Heating houses, P1c: A spectrum of waves

<b>Assessable learning outcomes both tiers: standard demand</b>	<b>Assessable learning outcomes Higher Tier only: high demand</b>
<p>Explain how energy is transferred in terms of:</p> <ul style="list-style-type: none"> <li>• conduction</li> <li>• convection</li> <li>• radiation</li> </ul> <p>and how such losses can be reduced in homes by energy saving measures to include:</p> <ul style="list-style-type: none"> <li>• loft insulation</li> <li>• double glazing</li> <li>• cavity wall insulation.</li> </ul> <p>Understand and use the terms source and sink in the context of energy lost from houses.</p>	<p>Describe how energy is transferred by:</p> <ul style="list-style-type: none"> <li>• conduction - transfer of KE between particles, to include the role played by free electrons</li> <li>• convection – how expansion when a liquid or gas is heated causes a change of density which results in (bulk) fluid flow</li> <li>• radiation – infrared radiation is an electromagnetic wave and needs no medium.</li> </ul> <p>Explain how there will be energy loss in a cavity wall and what further measures could be taken to limit this loss.</p>
<p>Interpret data for different energy saving strategies to include calculations involving:</p> <ul style="list-style-type: none"> <li>• initial cost</li> <li>• annual saving on energy bills</li> <li>• payback time.</li> </ul> <p>Use the equation:</p> $\text{efficiency} = \frac{\text{useful energy output} (\times 100\%)}{\text{total energy input}}$ <p>given the wasted energy and total energy input; efficiency can be expressed in ratio or percentage terms.</p> <p>Interpret and complete information presented in Sankey diagrams, to show understanding that energy is conserved.</p>	<p>Explain, in the context of the home, the concepts of conduction, convection and radiation (absorption and emission) in terms of:</p> <ul style="list-style-type: none"> <li>• the design features of the home</li> <li>• the design and use of everyday appliances in the home</li> <li>• energy saving strategies.</li> </ul> <p>Use the equation:</p> $\text{efficiency} = \frac{\text{useful energy output} (\times 100\%)}{\text{total energy input}}$ <p>to calculate the useful energy output, total energy input or wasted energy, which may be used to complete a Sankey diagram.</p> <p>Efficiency can be expressed in ratio or percentage terms.</p>

### Module P1: Energy For The Home

#### Item P1c: A spectrum of waves

**Summary:** Infrared radiation has been introduced in the context of heat transfer, but before further uses of electromagnetic (e-m) waves are considered, the properties of transverse waves are introduced. The electromagnetic spectrum is outlined, with a focus on the communication uses of non-ionising e-m waves. Some of the practical limitations of using waves are related to wavelength.

Suggested practical and research activities to select from	Assessable learning outcomes Foundation Tier only: low demand
Looking at and measuring waves: <ul style="list-style-type: none"> <li>• in ripple tanks</li> <li>• in PowerPoint simulations</li> <li>• using a CRO</li> <li>• using a 'slinky'.</li> </ul>	Identify and name the main features of a transverse wave: <ul style="list-style-type: none"> <li>• trough and crest</li> <li>• amplitude</li> <li>• wavelength.</li> </ul>
	Recall that all electromagnetic waves travel at the same high speed in space or a vacuum. Use the equation: $\text{wave speed} = \text{frequency} \times \text{wavelength}$
Carry out raybox, mirror and prism experiments to demonstrate ray tracing techniques for reflection and refraction.	Recall that electromagnetic waves travel in straight lines through a particular medium.  Use ray diagrams to describe reflection at single plane (flat) boundaries.  Recognise that refraction involves a change in direction of a wave due to the wave passing from one medium into another.
Disperse white light with a prism.  Recreate William Herschel's experiment to discover infrared radiation and its link to the visible spectrum.  Sort and match activities to look at the properties and uses of the different parts of the electromagnetic spectrum.	Identify the seven types of electromagnetic waves that comprise the spectrum and place them in ascending order of frequency.  Describe an example of a communications use for radio, microwave, infrared and visible light.

## Module P1: Energy For The Home

### Item P1c: A spectrum of waves

**Links to other items:** P1b: Keeping homes warm, P1d: Light and lasers, P1e: Cooking and communicating using waves, P1f: Data transmission, P1g: Wireless signals, P1h: Stable Earth, P2c: Global warming, P4d: Ultrasound, P4g: Treatment, P5e: Satellite communication, P5f: Nature of waves, P5g: Refraction of waves, P5h: Optics

Assessable learning outcomes both tiers: standard demand	Assessable learning outcomes Higher Tier only: high demand
Describe the main features of a transverse wave: <ul style="list-style-type: none"> <li>• trough and crest</li> <li>• amplitude</li> <li>• wavelength</li> <li>• frequency – as the number of complete waves, cycles, or oscillations per second.</li> </ul>	
Determine the value of the wavelength or the frequency of a wave from a diagram and be able to use the value in the equation:  $\text{wave speed} = \text{frequency} \times \text{wavelength}$	Use the equation including a change of subject and/or use of standard form (or the use of a scientific notation calculator):  $\text{wave speed} = \text{frequency} \times \text{wavelength}$
Use basic ray diagrams to demonstrate reflection at multiple plane (flat) boundaries.  Understand why refraction occurs at the boundary between mediums.  Describe diffraction of waves at an opening.	Describe a diffraction pattern for waves, including the significance of the size of the opening or barrier relative to the wavelength.
Identify the seven types of electromagnetic waves that comprise the spectrum and place them in order of frequency or wavelength.  Relate the size of a communications receiver to the wavelength for radio, microwave, infrared and visible light.	Describe and explain the limiting effects of diffraction on wave based sensors, to include: <ul style="list-style-type: none"> <li>• telescopes</li> <li>• optical microscopes.</li> </ul>

### Module P1: Energy For The Home

#### Item P1d: Light and lasers

**Summary:** The use of light as a source of digital communication, from Morse signalling to present day laser technology, has made rapid communication possible. This item develops ideas about communication at the speed of light, including applications of Total Internal Reflection.

Suggested practical and research activities to select from	Assessable learning outcomes Foundation Tier only: low demand
<p>Show that a message can be transmitted using a signal lamp.</p> <p>Relate the flashing signal light messages to the use of Morse code.</p>	<p>Describe how, historically, the use of light greatly increased the speed of communication but that it requires the use of a code.</p>
<p>Carry out an experiment to measure the critical angle for perspex or glass.</p> <p>Show that lengths of optical fibre and a pencil torch can make a model of a fibre optic lamp.</p> <p>Show that infrared radiation can be transmitted along a length of optical fibre.</p> <p>Show that optical fibres can transmit a signal from tape recorder or CD player to an amplifier (and loudspeaker) or send a program from one computer to another.</p>	<p>Recognise, in the context of optical fibres, where Total Internal Reflection (TIR) happens:</p> <ul style="list-style-type: none"> <li>• glass-air boundary</li> <li>• water-air boundary</li> <li>• perspex-air boundary.</li> </ul> <p>Understand how light and infrared radiation can travel along an optical fibre from one end to another by reflection from the sides of the fibre.</p>
<p>Examine the surface of a CD under a laboratory microscope and then look at images from the internet or other resource showing 10 000 × magnification.</p>	<p>Understand how the properties of light produced by lasers allows them to be used for:</p> <ul style="list-style-type: none"> <li>• surgery and dental treatment</li> <li>• cutting materials in industry</li> <li>• weapon guidance</li> <li>• laser light shows.</li> </ul>

### Module P1: Energy For The Home

#### Item P1d: Light and lasers

**Links to other items:** P4d: Ultrasound, P5f: Nature of waves, P5g: Refraction of waves, P5h: Optics

<b>Assessable learning outcomes both tiers: standard demand</b>	<b>Assessable learning outcomes Higher Tier only: high demand</b>
<p>Describe how light was used as a means of communication:</p> <ul style="list-style-type: none"> <li>signals sent in the form of Morse code which is a series of on off signals</li> <li>signals relayed between stations to cover larger distances.</li> </ul> <p>Describe why Morse code is a digital signal.</p>	<p>Explain the advantages and disadvantages of using light, radio and electrical signals for communication.</p>
<p>Describe what happens to light incident on a boundary, e.g. glass-air, water-air or perspex-air boundary, below, at and above the critical angle.</p> <p>Understand how transfer of light along an optical fibre depends on the critical angle of the incident light.</p>	<p>Describe applications of Total Internal Reflection (TIR) in fibre optics.</p>
<p>Recall that a laser produces a narrow beam of light of a single colour (monochromatic).</p>	<p>Explain why most lasers produce an intense coherent beam of light:</p> <ul style="list-style-type: none"> <li>waves have the same frequency</li> <li>waves are in phase with each other</li> <li>waves have low divergence.</li> </ul> <p>Explain how a laser beam is used in a CD player by reflection from the shiny surface:</p> <ul style="list-style-type: none"> <li>information is stored on the bottom surface</li> <li>information is stored digitally</li> <li>information in the form of patterns of bumps (known as pits)</li> <li>a CD will contain billions of pits.</li> </ul>

### Module P1: Energy For The Home

#### Item P1e: Cooking and communicating using waves

**Summary:** All radiations in the electromagnetic spectrum can be dangerous but they also have many uses. Infrared radiation and microwaves are useful for cooking since they cause heating in objects that absorb them. Microwaves are used for mobile phone communications. This item develops ideas about the properties of infrared and microwave radiation and examines their dangers and uses.

Suggested practical and research activities to select from	Assessable learning outcomes Foundation Tier only: low demand
<p>Examine household objects that work by infrared radiation:</p> <ul style="list-style-type: none"> <li>• radiator (does not glow red)</li> <li>• toaster (does glow red)</li> <li>• remote controls use a fine beam of infrared radiation.</li> </ul> <p>Carry out an experiment to measure the temperature increase near an object emitting infrared radiation.</p>	<p>Interpret information on the electromagnetic spectrum to include microwaves and infrared radiation.</p> <p>Understand how the emission and absorption of infrared radiation is affected by the properties of the surface of an object. Properties to include:</p> <ul style="list-style-type: none"> <li>• surface temperature</li> <li>• colour (black or white)</li> <li>• texture (shiny or dull).</li> </ul> <p>Recognise that microwaves cause heating when absorbed by water or fat and that this is the basis of microwave cooking.</p>
<p>Carry out an experiment to show that older mobile phones or a microwave oven in use emit radiation that causes interference with a radio signal.</p>	<p>Recall that mobile phones use microwave signals.</p>
<p>Interpret information about the use and safety of mobile phone technology, e.g. using internet search.</p> <p>Survey opinions about the positioning of mobile phone masts.</p> <p>Research the evidence for and against the possible damage to humans when using mobile phones and present the findings in the form of a leaflet.</p>	<p>Describe some concerns about children using mobile phones.</p> <p>Recall that different studies into the effects of mobile phone use have reached conflicting conclusions.</p>

### Module P1: Energy For The Home

**Item P1e:** Cooking and communicating using waves

**Links to other items:** P1b: Keeping homes warm, P1c: A spectrum of waves, P1f: Data transmission, P1g: Wireless signals

Assessable learning outcomes both tiers: standard demand	Assessable learning outcomes Higher Tier only: high demand
<p>Describe properties of infrared radiation:</p> <ul style="list-style-type: none"> <li>• heats the surface of the food</li> <li>• is reflected by shiny surfaces.</li> </ul> <p>Describe properties of microwaves:</p> <ul style="list-style-type: none"> <li>• penetrate (about 1cm) into food</li> <li>• are reflected by shiny metal surfaces</li> <li>• can cause burns when absorbed by body tissue</li> <li>• pass through glass and plastics.</li> </ul>	<p>Explain how microwaves and infrared transfer energy to materials:</p> <ul style="list-style-type: none"> <li>• infrared is absorbed only by particles on the surface of the food increasing their KE</li> <li>• KE is transferred to the centre of the food by conduction or convection</li> <li>• microwaves are absorbed only by water or fat particles in outer layers of the food increasing their KE.</li> </ul> <p>Describe how the energy associated with microwaves and infrared depend on their frequency and relate this to their potential dangers.</p>
<p>Describe factors that limit the transmission of information over large distances using microwaves.</p>	<p>Explain how signal loss with microwaves happens because of:</p> <ul style="list-style-type: none"> <li>• adverse weather and large areas of surface water scatter signals</li> <li>• loss of line of sight due to curvature of the Earth</li> <li>• no diffraction of microwaves around large objects</li> <li>• interference between signals.</li> </ul> <p>Describe how the problems of signal loss are reduced by:</p> <ul style="list-style-type: none"> <li>• limiting the distance between transmitters</li> <li>• high positioning of transmitters.</li> </ul>
<p>Describe why there may or may not be dangers:</p> <ul style="list-style-type: none"> <li>• to residents near the site of a mobile phone transmitter mast</li> <li>• to users of mobile phones.</li> </ul> <p>Describe how potential dangers may be increased by frequent use.</p> <p>Explain how publishing scientific studies into the effects of mobile phone microwave radiation enables results to be checked.</p>	<p>Understand that in the presence of conflicting evidence individuals and society must make choices about mobile phone usage and location of masts in terms of balancing risk and benefit.</p>



## Module P1: Energy For The Home

### Item P1f: Data transmission

**Summary:** Infrared radiation is not only useful for cooking and heating. It is used in remote controls to make life easier, whether it is changing channels on the television, opening car doors or opening the garage door when we get home on a cold, wet evening. Infrared radiation is also used to carry information in signals that can be transmitted over long distances using optical fibres. This item considers how we use infrared radiation.

<b>Suggested practical and research activities to select from</b>	<b>Assessable learning outcomes Foundation Tier only: low demand</b>
Examine the properties of infrared radiation e.g. reflecting the beam from a remote control to a television and showing it to be absorbed.	Describe everyday uses of infrared radiation to include: <ul style="list-style-type: none"> <li>• in remote controls (TV, video and DVD players, automatic doors)</li> <li>• short distance data links for computers or mobile phones.</li> </ul>
Examine a passive infrared sensor and images captured by infrared cameras.	Understand how passive infrared sensors and thermal imaging cameras work: <ul style="list-style-type: none"> <li>• infrared sensors detect body heat.</li> </ul>
Examine waveforms of analogue and digital signals using an oscilloscope.  Carry out research using the internet, to evaluate the reasons for, and time scale of, the switching from analogue to digital broadcasts. Construct a time line (paper or using IT) to show the progression from the first radio and TV broadcasts to the use of digital transmissions.	Describe the differences between analogue and digital signals: <ul style="list-style-type: none"> <li>• analogue signals have a continuously variable value</li> <li>• digital signals are either on (1) or off (0).</li> </ul>

### Module P1: Energy For The Home

**Item P1f:** Data transmission

**Links to other items:** P1c: A spectrum of waves, P1d: Light and lasers, P5g: Refraction of waves

<b>Assessable learning outcomes both tiers: standard demand</b>	<b>Assessable learning outcomes Higher Tier only: high demand</b>
Describe how infrared signals can carry information to control electrical or electronic devices.	Explain how the signal from an infrared remote control uses a set of digital signals (or codes) to control different functions of electrical or electronic devices.
Understand why it is easier to remove noise from digital signals.	Explain how the properties of digital signals played a part in the switch to digital TV and radio broadcasts, to include use of multiplexing.
Describe the transmission of light in optical fibres: <ul style="list-style-type: none"> <li>• optical fibres allow the rapid transmission of data</li> <li>• optical fibres allow the transmission of data pulses using light.</li> </ul>	Describe advantages of using optical fibres to allow more information to be transmitted: <ul style="list-style-type: none"> <li>• multiplexing</li> <li>• lack of interference in the final signal.</li> </ul>

### Module P1: Energy For The Home

#### Item P1g: Wireless signals

**Summary:** Today's hi-tech world demands that people can always receive both phone calls and email very rapidly. This item develops ideas about global communication, the benefits of wireless transmission, and the impact of this culture on modern society. The expanding use of digital signals is examined.

Suggested practical and research activities to select from	Assessable learning outcomes Foundation Tier only: low demand
<p>Survey of use of wireless technology within the class.</p> <p>Make a wall chart or PowerPoint presentation to illustrate the many uses of wireless technology.</p>	<p>Describe how radiation used for communication can be reflected.</p> <p>Recognise that wireless technology uses electromagnetic radiation for communication.</p> <p>Describe the advantages of wireless technology:</p> <ul style="list-style-type: none"> <li>• no external/direct connection to a telephone line needed</li> <li>• portable and convenient</li> <li>• allows access when on the move</li> </ul> <p>but an aerial is needed to pick up the signals.</p>
<p>Use radio or programme guides to make a chart of radio stations and frequencies.</p> <p>Examine the quality of radio and mobile phone reception in the area.</p> <p>Show that the quality of digital radio reception is superior to analogue reception.</p> <p>Research the expansion of Digital Audio Band (DAB) broadcasting.</p> <p>Construct a timeline to show the events from the first transmission of radio signals to the digital switch over.</p>	<p>Interpret data, including information given in diagram form, on digital and analogue signals.</p>

### Module P1: Energy For The Home

#### Item P1g: Wireless signals

**Links to other items:** P1c: A spectrum of waves, P5e: Satellite communication, P5f: Nature of waves, P5g: Refraction of waves

<b>Assessable learning outcomes both tiers: standard demand</b>	<b>Assessable learning outcomes Higher Tier only: high demand</b>
<p>Recall how radiation used for communication can be refracted and reflected and how this can be an advantage or disadvantage for good signal reception.</p> <p>Describe common uses of wireless technology:</p> <ul style="list-style-type: none"> <li>• TV and radio</li> <li>• mobile phones</li> <li>• laptop computers.</li> </ul>	<p>Explain how long-distance communication depends on:</p> <ul style="list-style-type: none"> <li>• the refraction and resulting reflection of waves from the ionosphere</li> <li>• being received by and re-transmitted from satellites.</li> </ul> <p>Recall that the refraction and reflection in the ionosphere is similar to TIR for light.</p>
<p>Understand why nearby radio stations use different transmission frequencies.</p> <p>Describe advantages and disadvantages of DAB broadcasts:</p> <ul style="list-style-type: none"> <li>• more stations available</li> <li>• less interference with other broadcasts</li> <li>• may give poorer audio quality compared to FM</li> <li>• not all areas covered.</li> </ul>	<p>Explain how the refraction and diffraction of radiation can affect communications:</p> <ul style="list-style-type: none"> <li>• refraction at the interfaces of different layers of Earth's atmosphere</li> <li>• diffraction by transmission dishes results in signal loss.</li> </ul> <p>Explain the advantage of digital radio, in terms of lack of interference, including that between other broadcasts/stations.</p>

## Module P1: Energy For The Home

### Item P1h: Stable Earth

**Summary:** Waves carry information. The information can be extracted even from naturally occurring waves, such as seismic waves generated within the Earth. Some waves are potentially harmful to living organisms. The incidents of skin cancer are rising, even in the UK. This item develops ideas surrounding these and other observations. It also examines how climate is being affected by natural and human activity.

<b>Suggested practical and research activities to select from</b>	<b>Assessable learning outcomes Foundation Tier only: low demand</b>
<p>Examine seismographic traces of recent earthquakes.</p> <p>Make a seismic trace using a pen suspended from a retort stand and striking the bench.</p> <p>Test seismometer applications in modern smart phones.</p>	<p>Describe earthquakes as producing shock waves which can:</p> <ul style="list-style-type: none"> <li>• be detected by seismometers</li> <li>• be recorded on a seismograph</li> <li>• cause damage to buildings and the Earth's surface</li> <li>• cause a tsunami.</li> </ul>
<p>Examine data that shows the increase in cases of skin cancer linked to more frequent exposure to UV.</p> <p>Produce a wall chart or PowerPoint presentation showing the dangers of exposure to UV and/or protection measures against over exposure.</p> <p>Make a leaflet to show people the dangers of using sun beds.</p> <p>Construct a chart showing a range of sun protection factors (SPFs) and the corresponding safe exposure times.</p>	<p>Recall that exposure to ultraviolet radiation can cause:</p> <ul style="list-style-type: none"> <li>• suntan</li> <li>• sunburn</li> <li>• skin cancer</li> <li>• cataracts</li> <li>• premature skin aging.</li> </ul> <p>Recognise that sunscreens (e.g. sun block or sun cream) can reduce damage caused by ultraviolet radiation:</p> <ul style="list-style-type: none"> <li>• less damage when higher factors are used</li> <li>• high factors allow longer exposure without burning.</li> </ul>
<p>Produce a wall chart showing how pollution from CFCs has enlarged the hole in the ozone layer over Antarctica and the resulting increased threat of exposure to more UV in that area.</p>	<p>Recall that the discovery of the reduction of ozone levels over Antarctica was unexpected.</p> <p>Describe how scientists used existing scientific ideas to explain their measurements.</p>

## Module P1: Energy For The Home

### Item P1h: Stable Earth

Assessable learning outcomes both tiers: standard demand	Assessable learning outcomes Higher Tier only: high demand
<p>Recall that two types of seismic waves are:</p> <ul style="list-style-type: none"> <li>longitudinal P waves which travel through both solids and liquids and travel faster than S waves</li> <li>transverse S waves which travel through solids but not through liquids and travel slower than P waves.</li> </ul>	<p>Describe how data on seismic waves transmitted through the Earth can be used to provide evidence for its structure:</p> <ul style="list-style-type: none"> <li>P waves travel through solid and liquid rock (i.e. all layers of the Earth)</li> <li>S waves cannot travel through liquid rock (i.e. the outer core).</li> </ul>
<p>Explain how darker skins reduce cancer risk:</p> <ul style="list-style-type: none"> <li>absorb more ultraviolet radiation</li> <li>less ultraviolet radiation reaches underlying body tissues.</li> </ul> <p>Interpret data about sun protection factor (no recall is expected).</p> <p>Calculate how long a person can spend in the Sun without burning from knowledge of the sun protection factor (SPF) of sunscreens (e.g. sun block or sun cream).</p> <p>Describe how people have been informed of the risk of exposure to ultraviolet radiation, including from the use of sun beds, in order to improve public health.</p>	<p>Explain how the ozone layer protects the Earth from ultraviolet radiation.</p> <p>Describe how:</p> <ul style="list-style-type: none"> <li>environmental pollution from CFCs has depleted the ozone layer</li> <li>this allows more ultraviolet radiation to reach Earth</li> <li>the potential danger to human health increases because of this.</li> </ul>
<p>Describe how scientists verified their measurements of ozone reduction, and the steps they took to increase confidence in their explanation:</p> <ul style="list-style-type: none"> <li>measurements repeated with new equipment</li> <li>measurements repeated by different scientists</li> <li>predictions tested based on the explanation.</li> </ul>	<p>Describe how the discovery of the hole in the ozone layer over Antarctica changed the behaviour of society at an international level.</p>

### 3.5 Module P2: Living For The Future (Energy Resources)

#### Module P2: Living For The Future (Energy Resources)

##### Item P2a: Collecting energy from the Sun

**Summary:** The Sun has supplied our planet with energy for a long time. This item shows how solar energy can be used, in a sustainable way, to provide us with some of our energy needs.

Suggested practical and research activities to select from	Assessable learning outcomes Foundation Tier only: low demand
<p>Investigate how the voltage and current from a photocell varies with distance from the light source.</p> <p>Research the use of photocells for providing electricity in remote locations.</p> <p>Investigate how the power of a photocell depends on its surface area and its distance from the light source.</p> <p>Investigate how photocells can be connected to increase their voltage.</p>	<p>Recall that photocells:</p> <ul style="list-style-type: none"> <li>• transfer light into electricity</li> <li>• produce direct current (DC)</li> <li>• can operate in remote locations</li> <li>• have a power or current that depends on the surface area exposed to sunlight.</li> </ul> <p>Recall that DC electricity is current in the same direction all the time.</p>
<p>Build a solar collector e.g. from aluminium foil and an umbrella.</p> <p>Investigate a model glasshouse.</p> <p>Survey and research the use of passive solar heating of buildings.</p> <p>Survey and research the use and distribution of wind turbines in the UK.</p> <p>Research and debate to what extent solar energy can help ensure the UK's future energy security.</p>	<p>Describe how the Sun's energy can be harnessed:</p> <ul style="list-style-type: none"> <li>• radiation from the Sun can be absorbed by a surface and transferred into heat energy</li> <li>• produces convection currents (wind) to drive turbines</li> <li>• how glass can be used to provide passive solar heating for buildings</li> <li>• light can be reflected to a focus by a curved mirror.</li> </ul>

## Module P2: Living For The Future (Energy Resources)

**Item P2a:** Collecting energy from the Sun

**Links to other items:** P2c: Global warming, P3e: Energy on the move

<b>Assessable learning outcomes both tiers: standard demand</b>	<b>Assessable learning outcomes Higher Tier only: high demand</b>
<p>Describe some advantages and disadvantages of using photocells to provide electricity:</p> <ul style="list-style-type: none"> <li>• low maintenance</li> <li>• no need for power cables</li> <li>• no need for fuel</li> <li>• long life</li> <li>• renewable energy resource</li> <li>• no polluting waste</li> <li>• no power at night or in bad weather.</li> </ul>	<p>Describe how light produces electricity in a photocell:</p> <ul style="list-style-type: none"> <li>• energy absorbed by photocell</li> <li>• electrons are knocked loose from the silicon atoms in the crystal</li> <li>• electrons flow freely.</li> </ul> <p>Understand how the current and power produced in a photocell depends on:</p> <ul style="list-style-type: none"> <li>• light intensity</li> <li>• surface area exposed</li> <li>• distance from the light source.</li> </ul>
<p>Describe the advantages and disadvantages of wind turbines:</p> <ul style="list-style-type: none"> <li>• renewable</li> <li>• no polluting waste</li> <li>• visual pollution</li> <li>• dependency on wind speed</li> <li>• appropriate space and position needed.</li> </ul>	<p>Explain why passive solar heating works:</p> <ul style="list-style-type: none"> <li>• glass is transparent to Sun's radiation</li> <li>• heated surfaces emit infrared radiation of longer wavelength</li> <li>• glass reflects this longer wavelength infrared.</li> </ul> <p>Recall that an efficient solar collector must track the position of the Sun in the sky.</p>



### Module P2: Living For The Future (Energy Resources)

#### Item P2b: Generating electricity

**Summary:** Most of our electricity is generated in power stations by burning fuels. This item shows how power stations work and how energy is transported to our homes and factories.

Suggested practical and research activities to select from	Assessable learning outcomes Foundation Tier only: low demand
<p>Build a model generator with magnets and coils to produce electricity.</p> <p>Examine the difference between a model generator and the generator in a power station.</p> <p>Examine ways in which the current of a generator can be increased.</p> <p>Examine the output of a generator with an oscilloscope.</p>	<p>Describe how to generate electricity using the dynamo effect, by moving the coil or the magnet.</p> <p>Recall that a generator produces alternating current (AC).</p> <p>Recall that a battery produces direct current (DC).</p>
<p>Find out about the construction of power stations.</p> <p>Demonstrate a steam engine transferring chemical energy of a fuel into kinetic energy.</p>	<p>Describe the main stages in the production and distribution of electricity:</p> <ul style="list-style-type: none"> <li>• source of energy</li> <li>• power station produces electricity</li> <li>• national grid of power lines connecting station to consumers</li> <li>• consumers are homes, factories, offices and farms.</li> </ul>
	<p>Recognise that there is significant waste of energy in a conventional power station.</p> <p>Use the equation in the context of a power station:</p> $\text{efficiency} = \frac{\text{useful energy output} (\times 100\%)}{\text{total energy input}}$ <p>given the useful energy output and the total energy input. Efficiency can be expressed in ratio or percentage terms.</p>

### Module P2: Living For The Future (Energy Resources)

#### Item P2b: Generating electricity

**Links to other items:** P2c: Global warming, P2d: Fuels for power, P4h: Fission and fusion, P6f: Generating

<b>Assessable learning outcomes both tiers: standard demand</b>	<b>Assessable learning outcomes Higher Tier only: high demand</b>
<p>Describe and recognise the ways that the dynamo effect can be increased (to give more current).</p> <p>Describe and interpret AC using a voltage-time graph.</p>	
<p>Describe how simple AC generators work:</p> <ul style="list-style-type: none"> <li>• coil of wire</li> <li>• magnetic field</li> <li>• coil and field close</li> <li>• relative motion between coil and field.</li> </ul> <p>Describe how electricity is generated at a conventional power station:</p> <ul style="list-style-type: none"> <li>• burning fuel</li> <li>• producing steam</li> <li>• spinning a turbine</li> <li>• turbine turns generator.</li> </ul>	
<p>Use the equation in the context of a power station:</p> $\text{efficiency} = \frac{\text{useful energy output} (\times 100\%)}{\text{total energy input}}$ <p>given the useful energy output, wasted energy and the total energy input. Efficiency can be expressed in ratio or percentage terms.</p>	<p>Use the equation in the context of a power station to calculate useful energy output, total energy input or wasted energy.</p> $\text{efficiency} = \frac{\text{useful energy output} (\times 100\%)}{\text{total energy input}}$ <p>Efficiency can be expressed in ratio or percentage terms.</p>

## Module P2: Living For The Future (Energy Resources)

### Item P2c: Global warming

**Summary:** There is a large amount of discussion amongst scientists, politicians and the general public about the reasons for increased global warming. The greenhouse effect is considered to be a proven scientific explanation, but there are ongoing arguments about whether global warming is happening at all, and if it is happening, whether human activity is significantly influencing the process. This item provides a rich context in which to explore the importance of rigorous, evidence based scientific processes, and the need to effectively communicate complex scientific issues to the wider population.

Suggested practical and research activities to select from	Assessable learning outcomes Foundation Tier only: low demand
<p>Compare temperature changes inside sealed transparent containers with different gases inside.</p>	<p>Understand that some gases in the Earth's atmosphere prevent heat from radiating into space.</p> <p>Recall and recognise that this is known as the greenhouse effect.</p> <p>Recall and identify examples of greenhouse gases to include:</p> <ul style="list-style-type: none"> <li>• carbon dioxide</li> <li>• water vapour</li> <li>• methane.</li> </ul>
<p>Discuss the advantages and disadvantages of using fossil fuels for making electricity.</p> <p>Discuss the possible consequences of global warming.</p>	<p>Describe reasons for climate change caused by increased global warming:</p> <ul style="list-style-type: none"> <li>• increased energy use</li> <li>• increased CO<sub>2</sub> emissions</li> <li>• deforestation.</li> </ul>
<p>Find out about the evidence for global warming in the last 200 years.</p>	<p>Describe the difficulties of measuring global warming.</p> <p>Explain why scientists working on global warming should allow other scientists to use their data.</p>

## Module P2: Living For The Future (Energy Resources)

### Item P2c: Global warming

**Links to other items:** P2a: Collecting energy from the Sun, P2b: Generating electricity, P2e: Nuclear radiations, P4h: Fission and fusion

<b>Assessable learning outcomes both tiers: standard demand</b>	<b>Assessable learning outcomes Higher Tier only: high demand</b>
<p>Describe how electromagnetic radiation at most wavelengths can pass through the Earth's atmosphere, but certain wavelengths, particularly infrared, are absorbed by some gases in the atmosphere.</p> <p>Recall and identify natural and man-made sources of greenhouse gases (limited to water vapour, carbon dioxide and methane).</p>	<p>Explain the greenhouse effect in terms of:</p> <ul style="list-style-type: none"> <li>• short wavelength e-m radiation from the Sun is absorbed by and heats the Earth</li> <li>• the Earth radiates heat as longer wavelength infrared radiation</li> <li>• greenhouse gases absorb some infrared radiation, warming the atmosphere.</li> </ul> <p>Interpret data about the abundance and relative impact of greenhouse gases (limited to water vapour, carbon dioxide and methane).</p>
<p>Explain how human activity and natural phenomena both have effects on weather patterns including dust in the atmosphere:</p> <ul style="list-style-type: none"> <li>• from factories reflecting radiation from the city back to Earth causing warming</li> <li>• from volcanic ash and gases reflecting radiation from the Sun back into space causing cooling.</li> </ul>	<p>Interpret data about increased global warming and climate change as a result of natural or human activity (no recall is expected).</p>
<p>Describe scientific evidence which supports or refutes the idea of man-made global warming.</p> <p>Distinguish between opinion and evidence based statements in the context of the global warming debate.</p>	<p>Explain how it is possible to have good agreement between scientists about the greenhouse effect, but disagreement about whether human activity is affecting global warming.</p>

### Module P2: Living For The Future (Energy Resources)

#### Item P2d: Fuels for power

**Summary:** The heat energy for our power stations comes from a variety of sources. This unit considers the economic and environmental costs of the different sources we use today.

Suggested practical and research activities to select from	Assessable learning outcomes Foundation Tier only: low demand
<p>Measure the energy released by a fossil fuel by using a candle to heat water.</p> <p>Build a model digester to generate methane from biomass.</p> <p>Use software to find out or model how a nuclear power station operates.</p>	<p>Recall that fuels release energy as heat.</p> <p>Recall the common fuels used in power stations:</p> <ul style="list-style-type: none"> <li>• fossil fuels</li> <li>• renewable biomass – wood, straw and manure</li> <li>• nuclear fuels – uranium and sometimes plutonium.</li> </ul>
<p>Examine the use of an electricity meter or joule meter to measure energy transfer.</p> <p>Find out about the cost of electricity at different times of the day.</p> <p>Find out about the power of different electrical appliances.</p> <p>Research the use of electricity in their own home e.g. units used and power ratings.</p> <p>Research the efficiency rating of fridges, freezers washing machines and light bulbs.</p> <p>Research and explore how the demand for electricity is managed in the National Grid now and how this may change in the future.</p>	<p>Recall that the unit of power is the watt or kilowatt.</p> <p>Interpret data to show that the cost of using expensive electrical appliances depends on:</p> <ul style="list-style-type: none"> <li>• power rating in watts and kilowatts</li> <li>• the length of time it is switched on.</li> </ul> <p>Calculate the power rating of an appliance using the equation:</p> $\text{power} = \text{voltage} \times \text{current}$
<p>Research the National Grid.</p> <p>Demonstrate a model transmission line system with resistance wires and a pair of transformers.</p>	<p>Recall that transformers can be used to increase or decrease voltage.</p>

**Module P2: Living For The Future (Energy Resources)**
**Item P2d: Fuels for power**
**Links to other items:** P2b: Generating electricity, P2e: Nuclear radiations, P4h: Fission and fusion

<b>Assessable learning outcomes both tiers: standard demand</b>	<b>Assessable learning outcomes Higher Tier only: high demand</b>
Describe and evaluate the advantages and disadvantages of different energy sources; factors to include availability, risks and environmental impact.	
Calculate the power rating of an appliance using the equation, including conversion of power between watts and kilowatts: $\text{power} = \text{voltage} \times \text{current}$ State that the unit of electrical energy supplied is the kilowatt hour. Calculate the number of kilowatt hours given the: <ul style="list-style-type: none"> <li>• power in kilowatts</li> <li>• time in hours.</li> </ul> Use the equation: $\text{energy supplied} = \text{power} \times \text{time}$ Calculate the cost of energy supplied.	Use and manipulate the equation: $\text{power} = \text{voltage} \times \text{current}$ Use the kilowatt hour as a measure of the energy supplied. Use the equation: $\text{energy supplied} = \text{power} \times \text{time}$ to calculate: <ul style="list-style-type: none"> <li>• power in kW or W</li> <li>• time in hours.</li> </ul> Describe the advantages and disadvantages (for consumers and producers) of using off-peak electricity in the home.
Explain why transformers are used in the National Grid to increase the voltage: <ul style="list-style-type: none"> <li>• electrical energy is transmitted at high voltage to reduce energy waste and costs.</li> </ul>	Explain how for a given power transmission, an increased voltage reduces current, so decreasing energy waste by reducing heating of cables.

## Module P2: Living For The Future (Energy Resources)

### Item P2e: Nuclear radiations

**Summary:** Most people know that radioactivity can be dangerous, but do not understand why. This item develops ideas about the uses of radioactivity, the nature of ionising radiations and how to handle their sources safely.

Suggested practical and research activities to select from	Assessable learning outcomes Foundation Tier only: low demand
	<p>Recognise examples where nuclear radiation can be beneficial or harmful:</p> <ul style="list-style-type: none"> <li>• state one example of a beneficial use</li> <li>• harmful effect: damages living cells/causes cancer.</li> </ul> <p>Understand that radioactive materials give out nuclear radiation over time.</p>
<p>Teacher to use radiation detectors to show the ionising properties of nuclear radiation.</p> <p>Show the differing ranges and penetrating power of alpha, beta and gamma radiation.</p> <p>Research how to handle radioactive sources safely.</p> <p>Research how nuclear radiation can damage workers if proper safety precautions are not taken.</p> <p>Debate the risks and benefits of using radioactive materials.</p>	<p>Recall the three types of nuclear radiation:</p> <ul style="list-style-type: none"> <li>• alpha</li> <li>• beta</li> <li>• gamma.</li> </ul> <p>Understand that nuclear radiation causes ionisation and this is potentially harmful.</p>
<p>Demonstrate the safety measures to be taken when handling radioactive sources after identifying appropriate risk and hazard assessments.</p> <p>Do research to find out how radioactive waste from nuclear power stations is disposed of.</p>	<p>Describe how to handle radioactive materials safely:</p> <ul style="list-style-type: none"> <li>• protective clothing</li> <li>• tongs / keep your distance</li> <li>• short exposure time</li> <li>• shielded and labelled storage.</li> </ul> <p>Describe waste from nuclear power as:</p> <ul style="list-style-type: none"> <li>• radioactive</li> <li>• harmful</li> <li>• not causing global warming.</li> </ul>

## Module P2: Living For The Future (Energy Resources)

### Item P2e: Nuclear radiations

**Links to other items:** P2d: Fuels for power, P4e: What is radioactivity? P4f: Uses of radioisotopes, P4g: Treatment

Assessable learning outcomes both tiers: standard demand	Assessable learning outcomes Higher Tier only: high demand
<p>Describe examples of beneficial uses of radiation:</p> <ul style="list-style-type: none"> <li>• alpha – smoke detectors</li> <li>• beta – some tracers and paper thickness gauges</li> <li>• gamma – treating cancer, non-destructive testing, tracers and sterilising equipment.</li> </ul>	
<p>Describe the relative penetrating power of alpha, beta and gamma:</p> <ul style="list-style-type: none"> <li>• alpha stopped by a few sheets of paper</li> <li>• beta stopped by a few mm of aluminium</li> <li>• gamma mostly stopped by a few cm of lead.</li> </ul> <p>Understand that nuclear radiation can form positive ions when electrons are lost from atoms.</p> <p>Understand that nuclear radiation can form negative ions when electrons are gained by atoms.</p>	<p>Interpret data and describe experiments that show how alpha, beta and gamma can be identified by their relative penetrating powers.</p> <p>Understand that ionisation can initiate chemical reactions.</p> <p>Explain how ionisation can damage human cells.</p>
<p>Recall that uranium is a non-renewable resource. Recall that plutonium:</p> <ul style="list-style-type: none"> <li>• is a waste product from nuclear reactors</li> <li>• can be used to make nuclear bombs.</li> </ul> <p>Describe some ways of disposing of radioactive waste e.g.:</p> <ul style="list-style-type: none"> <li>• low level waste in land-fill sites</li> <li>• encased in glass and left underground</li> <li>• reprocessed.</li> </ul>	<p>Describe the advantages and disadvantages of nuclear power.</p> <p>Explain the problems of dealing with radioactive waste:</p> <ul style="list-style-type: none"> <li>• remains radioactive for a long time</li> <li>• terrorist risk</li> <li>• must be kept out of groundwater</li> <li>• acceptable radioactivity level may change over time.</li> </ul>



## Module P2: Living For The Future (Energy Resources)

### Item P2f: Exploring our Solar System

**Summary:** When we look at the night sky, we can sometimes see the Moon, artificial satellites, planets in our Solar System and the billions of stars which make up the Universe. This item discusses the problems involved in visiting other parts of the Solar System.

Suggested practical and research activities to select from	Assessable learning outcomes Foundation Tier only: low demand
<p>Build or make a scale model of the Solar System and then work out where the nearest star would be on the same scale.</p> <p>You are a travel agent. Produce a brochure for aliens who might visit our Solar System.</p>	<p>Identify the relative positions of the Earth, Sun and planets (includes the order of the planets).</p> <p>Recall that the Universe consists of:</p> <ul style="list-style-type: none"> <li>• stars and planets</li> <li>• comets and meteors</li> <li>• black holes</li> <li>• large groups of stars called galaxies.</li> </ul> <p>Explain why stars give off their own light and can be seen or detected even though they are far away.</p>
<p>Research the exploration of the Moon by the Apollo missions.</p> <p>Research the problems of manned space travel.</p> <p>Design a manned mission to Mars.</p> <p>Research and debate the advantages and disadvantages of space exploration (which is very costly to several nations).</p>	<p>Recall that radio signals take a long time to travel through the Solar System.</p>
<p>Research the exploration of our Solar System by robot spacecraft.</p> <p>Evaluate reasons why we might need to explore our Solar System.</p> <p>Debate the advantages and disadvantages of using robot spacecraft to explore the Solar System.</p>	<p>Compare the resources needed by manned and unmanned spacecraft.</p> <p>Describe why unmanned spacecraft are sent into space.</p>

### Module P2: Living For The Future (Energy resources)

**Item P2f:** Exploring our Solar System

**Links to other items:** P2g: Threats to Earth

<b>Assessable learning outcomes both tiers: standard demand</b>	<b>Assessable learning outcomes Higher Tier only: high demand</b>
<p>Recall the relative sizes and nature of planets, stars, comets, meteors, galaxies and black holes.</p>	<p>Recall that circular motion requires a centripetal force.</p> <p>Understand that gravitational attraction provides the centripetal force for orbital motion.</p>
<p>Describe a light-year as the distance light travels in a year.</p> <p>Describe some of the difficulties of manned space travel between planets.</p>	<p>Explain why a light-year is a useful unit for measuring very large distances in space.</p>
<p>Recall that unmanned spacecraft can withstand conditions that are lethal to humans.</p> <p>Compare how information from space is returned to Earth from different distances:</p> <ul style="list-style-type: none"> <li>• distant planets require data to be sent back</li> <li>• nearby samples can be brought back to Earth for analysis.</li> </ul>	<p>Explain the advantages and disadvantages of using unmanned spacecraft to explore the Solar System.</p>

## Module P2: Living For The Future (Energy Resources)

### Item P2g: Threats to Earth

**Summary:** Most people ignore the threat of asteroid collision to the Earth. This item shows that the threat is real and has proved to be lethal many times in the past. Strategies for avoiding such catastrophes are explored.

Suggested practical and research activities to select from	Assessable learning outcomes Foundation Tier only: low demand
<p>Discuss the evidence for the presence of the Moon as the result of a collision between the Earth and another planet.</p>	<p>Understand that the Moon may be the remains of a planet which collided with the Earth billions of years ago.</p>
<p>Research the evidence for the extinction of the dinosaurs by an asteroid.</p> <p>Research and debate other theories for the extinction of dinosaurs.</p> <p>Discuss how the surface of the Moon provides evidence for the continual bombardment of the Earth by asteroids.</p>	<p>Recall that large asteroids have collided with the Earth in the past.</p> <p>Recall that asteroids are rocks.</p> <p>Describe some of the consequences of a collision with a large asteroid:</p> <ul style="list-style-type: none"> <li>• crater</li> <li>• ejection of hot rocks</li> <li>• widespread fires</li> <li>• sunlight blocked by dust</li> <li>• climate change</li> <li>• species extinction.</li> </ul>
<p>Research the history of Halley's comet.</p> <p>Research the exploration of comets by robot spacecraft.</p> <p>Discuss the collision of a comet with Jupiter.</p>	<p>Describe the make up of a comet:</p> <ul style="list-style-type: none"> <li>• made from ice and dust</li> <li>• has a tail formed from a trail of debris.</li> </ul>
<p>Debate the importance of funding telescopes to search for Near Earth Objects.</p> <p>Design a plan to deal with the threat of an asteroid collision.</p>	<p>Describe a Near Earth Object (NEO) as an asteroid or comet on a possible collision course with Earth.</p> <p>Describe how NEOs may be seen.</p>

## Module P2: Living For The Future (Energy Resources)

### Item P2g: Threats to Earth

**Links to other items:** P2f: Exploring our Solar System

<b>Assessable learning outcomes both tiers: standard demand</b>	<b>Assessable learning outcomes Higher Tier only: high demand</b>
<p>Describe how a collision between two planets can result in an Earth-Moon system:</p> <ul style="list-style-type: none"> <li>the planets collide</li> <li>their iron cores merge to form the core of the Earth</li> <li>less dense material orbits as the Moon.</li> </ul>	<p>Discuss the evidence for the Earth-Moon system as the result of a collision between two planets.</p>
<p>Describe asteroids:</p> <ul style="list-style-type: none"> <li>as being left over from the formation of the Solar System</li> <li>as being in orbit between Mars and Jupiter.</li> </ul> <p>Describe some of the evidence for past asteroid collisions:</p> <ul style="list-style-type: none"> <li>layers of unusual elements in rocks</li> <li>sudden changes in fossil numbers between adjacent layers of rock.</li> </ul>	<p>Explain why the asteroid belt is between Mars and Jupiter:</p> <ul style="list-style-type: none"> <li>the gravitational attraction of Jupiter disrupts the formation of a planet.</li> </ul>
<p>Describe comets:</p> <ul style="list-style-type: none"> <li>as having highly elliptical orbits</li> <li>as coming from objects orbiting the Sun far beyond the planets.</li> </ul> <p>Describe how the speed of a comet changes as it approaches a star.</p>	<p>Explain in terms of changing gravitational attraction, why the speed of a comet changes as it approaches a star.</p>
<p>Describe how observations of NEOs can be used to determine their trajectories.</p> <p>Explain why it is difficult to observe NEOs.</p>	<p>Suggest and discuss possible actions which could be taken to reduce the threat of NEOs:</p> <ul style="list-style-type: none"> <li>surveys by telescope</li> <li>monitoring by satellites</li> <li>deflection by explosions (when they are distant enough from Earth).</li> </ul>

### Module P2: Living For The Future (Energy resources)

#### Item P2h: The Big Bang

**Summary:** There are a number of theories about how the Universe was formed and how it will continue to evolve. This item develops ideas about the evolution of the Universe and its possible future. The Big Bang theory is considered.

Suggested practical and research activities to select from	Assessable learning outcomes Foundation Tier only: low demand
<p>Explore examples of the Doppler effect e.g. passing police siren, whirling a buzzer round on a string.</p> <p>Research Doppler simulations on PowerPoint.</p> <p>Build a model of the expanding Universe with a balloon to show that spots on the surface are moving faster and further away from each other as the balloon is inflated.</p> <p>Draw a time line for the age of the Universe.</p> <p>Discuss ideas about the origin of the Universe.</p>	<p>Describe some ideas about the Big Bang theory for the origin of the Universe:</p> <ul style="list-style-type: none"> <li>• started with an explosion</li> <li>• the Universe is still expanding.</li> </ul>
<p>Discuss ideas about the birth and death of stars.</p> <p>Research the evidence for the black hole at the centre of the Milky Way.</p> <p>Research and debate different models (scientific and non-scientific) which attempt to explain the start of the Universe.</p>	<p>Recall that stars:</p> <ul style="list-style-type: none"> <li>• have a finite 'life'</li> <li>• start as a huge gas cloud</li> <li>• are different sizes.</li> </ul> <p>Understand why not even light can escape from black holes.</p>
<p>Produce a timeline for changing models of the Universe.</p>	<p>Recognise that the accepted models of the size and shape of the Universe have changed over time.</p> <p>Describe and recognise the Ptolemaic and Copernican models of the Universe, and describe how they differ from each other and the modern day model.</p>

## Module P2: Living For The Future (Energy resources)

### Item P2h: The Big Bang

Assessable learning outcomes both tiers: standard demand	Assessable learning outcomes Higher Tier only: high demand
<p>Recall that:</p> <ul style="list-style-type: none"> <li>• most galaxies are moving away from us</li> <li>• distant galaxies are moving away more quickly</li> <li>• microwave radiation is received from all parts of the Universe.</li> </ul>	<p>Explain how the Big Bang theory accounts for:</p> <ul style="list-style-type: none"> <li>• light from other galaxies shifting to the red end of the spectrum</li> <li>• more distant galaxies generally showing greater red shift</li> <li>• estimating the age and starting point of the Universe.</li> </ul>
<p>Describe the end of the 'life cycle' of a small star:</p> <ul style="list-style-type: none"> <li>• red giant</li> <li>• planetary nebula</li> <li>• white dwarf.</li> </ul> <p>Describe the end of the 'life cycle' of a large star:</p> <ul style="list-style-type: none"> <li>• red supergiant</li> <li>• supernova</li> <li>• neutron star or black hole (for massive stars).</li> </ul>	<p>Describe the life history of a star:</p> <ul style="list-style-type: none"> <li>• interstellar gas cloud</li> <li>• gravitational collapse producing a proto star</li> <li>• thermonuclear fusion</li> <li>• long period of normal life (main sequence)</li> <li>• end depends on mass of star.</li> </ul> <p>Explain the properties of a black hole:</p> <ul style="list-style-type: none"> <li>• large mass, small volume and high density</li> <li>• strong gravitational attraction due to the large mass.</li> </ul>
<p>Describe the evidence or observations that caused Copernicus and Galileo to develop new scientific models of the Universe, and explain how technological advances contributed to the new models.</p>	<p>Explain why the theories of the Copernicus and Galileo models were considered controversial when they were announced, and were not widely adopted until many years had passed.</p>

### 3.6 Module P3: Forces For Transport

#### Module P3: Forces For Transport

##### Item P3a: Speed

**Summary:** Transport and road safety provide the context for this module. The abilities to describe and measure motion are used in the treatment of issues involving everyday transport. Speed is studied in this item; how it can be measured and calculated and how distance and time can be graphically represented. The activities on vehicle speeds allow the opportunity to collect and analyse scientific data. Using ICT to interpret the data and using creative thought can then lead to the development of theories and models.

Suggested practical and research activities to select from	Assessable learning outcomes Foundation Tier only: low demand
<p>Calculating speeds from measurements of time and distance (e.g. pupils running and walking, vehicles, pupil riding a bike, remote controlled toy cars).</p> <p>Practical experiment to investigate the speeds of vehicles near school:</p> <ul style="list-style-type: none"> <li>• are male drivers faster than female?</li> <li>• have the speed-bumps made any difference?</li> </ul> <p>Practical experiment to investigate the speeds of toy cars on ramps:</p> <ul style="list-style-type: none"> <li>• how does the slope angle or height affect the speed?</li> <li>• which cars are fastest?</li> </ul> <p>Find out how different speed cameras work.</p> <p>Exploration of speed records (cars, animals, planes, people etc). Make a wall chart or PowerPoint presentation to show the range of speed for land animals.</p>	<p>Use the equation:</p> $\text{average speed} = \frac{\text{distance}}{\text{time}}$ <p>to include change of units from km to m.</p> <p>Understand why one type of speed camera takes two photographs:</p> <ul style="list-style-type: none"> <li>• a certain time apart</li> <li>• when the vehicle moves over marked lines a known distance apart on the road.</li> </ul> <p>Understand how average speed cameras work.</p>
<p>Looking at data from cars, sport and animals then transferring it to graphical form for analysis (distance-time graphs).</p>	<p>Draw and interpret qualitatively graphs of distance against time.</p>

### Module P3: Forces For Transport

#### Item P3a: Speed

**Links to other items:** P3b: Changing speed, P3c: Forces and motion, P5b: Vectors and equations of motion

Assessable learning outcomes both tiers: standard demand	Assessable learning outcomes Higher Tier only: high demand
<p>Interpret the relationship between speed, distance and time including:</p> <ul style="list-style-type: none"> <li>increasing the speed, which increases the distance travelled in the same time</li> <li>increasing the speed reduces the time needed to cover the same distance.</li> </ul> <p>Use the equation, including a change of subject:</p> $\text{distance} = \text{average speed} \times \text{time}$ $= \frac{(u + v)}{2} \times t$	<p>Interpret the relationship between speed, distance and time to include the effect of changing any one or both of the quantities.</p> <p>Use the equation, including a change of subject and/or units:</p> $\text{distance} = \text{average speed} \times \text{time}$ $= \frac{(u + v)}{2} \times t$
<p>Describe and interpret the gradient (steepness) of a distance-time graph as speed (higher speed gives steeper gradient).</p>	<p>Draw and interpret graphs of distance against time:</p> <ul style="list-style-type: none"> <li>qualitatively for non-uniform speed</li> <li>calculations of speed from the gradient of distance-time graph for uniform speed.</li> </ul>



### Module P3: Forces For Transport

#### Item P3b: Changing speed

**Summary:** In this item the idea of acceleration is developed. The concept of velocity is introduced here, and is developed further in P5. Accelerations (involving the change in speed) of cars can be used and graphically illustrated and studied. Practical measurements of bicycles and sprint starts can be done to collect and analyse data. The experiments on acceleration allow the opportunity to collect and analyse science data using ICT tools and the interpretation of the data using creative thought to develop theories.

Suggested practical and research activities to select from	Assessable learning outcomes Foundation Tier only: low demand
Practical measurements of bicycles, sprint starts, falling objects can be done (using manual or electronic measurement) to collect and analyse real data for calculating acceleration.	Describe the trends in speed and time from a simple speed-time graph: <ul style="list-style-type: none"> <li>• horizontal line – constant speed</li> <li>• straight line positive gradient – increasing speed</li> <li>• straight line negative gradient – decreasing speed.</li> </ul>
Use of real car data from websites or magazines to illustrate and develop further the concepts of: <ul style="list-style-type: none"> <li>• speed</li> <li>• acceleration.</li> </ul>	Recognise that acceleration involves a change in speed (limited to motion in a straight line): <ul style="list-style-type: none"> <li>• speeding up involves an acceleration</li> <li>• slowing down involves a deceleration</li> <li>• greater change in speed (in a given time) results in higher acceleration.</li> </ul> Recall that acceleration is measured in metres per second squared ( $\text{m/s}^2$ ).  Use the equation: $\text{acceleration} = \frac{\text{change in speed}}{\text{time taken}}$ when given the change in speed.
	Recognise that direction is important when describing the motion of an object.  Understand that the velocity of an object is its speed combined with its direction.

### Module P3: Forces For Transport

#### Item P3b: Changing speed

**Links to other items:** P3a: Speed, P3c: Forces and motion, P5b: Vectors and equations of motion

<b>Assessable learning outcomes both tiers: standard demand</b>	<b>Assessable learning outcomes Higher Tier only: high demand</b>
<p>Describe, draw and interpret qualitatively, graphs of speed against time for uniform acceleration to include:</p> <ul style="list-style-type: none"> <li>greater acceleration shown by a higher gradient</li> <li>the significance of a positive or negative gradient</li> <li>calculations of distance travelled from a simple speed-time graph for uniform acceleration.</li> </ul>	<p>Describe, draw and interpret graphs of speed against time including:</p> <ul style="list-style-type: none"> <li>quantitatively for uniform acceleration</li> <li>calculations of distance travelled from a speed-time graph for uniform acceleration</li> <li>calculations of acceleration from a speed-time graph for uniform acceleration</li> <li>qualitative interpretation of speed-time graphs for non-uniform acceleration.</li> </ul>
<p>Describe acceleration as change in speed per unit time and that:</p> <ul style="list-style-type: none"> <li>increase in speed results from a positive acceleration</li> <li>decrease in speed results from a negative acceleration or deceleration.</li> </ul> <p>Use the equation including prior calculation of the change in speed:</p> $\text{acceleration} = \frac{\text{change in speed}}{\text{time taken}}$	<p>Explain how acceleration can involve either a change:</p> <ul style="list-style-type: none"> <li>in speed</li> <li>in direction</li> <li>in both speed and direction.</li> </ul> <p>Interpret the relationship between acceleration, change of speed and time to include the effect of changing any one or two of the quantities.</p> <p>Use the equation, including a change of subject:</p> $\text{acceleration} = \frac{\text{change in speed}}{\text{time taken}}$
<p>Recognise that for two objects moving in opposite directions at the same speed, their velocities will have identical magnitude but opposite signs.</p> <p>Calculate the relative velocity of objects moving in parallel.</p>	

### Module P3: Forces For Transport

#### Item P3c: Forces and motion

**Summary:** Before taking your driving test you need to pass a theory test. Part of this involves driving safely and knowledge of car stopping distances. Driving fast may be tempting but stopping safely is more important. In this item we start to understand the effects of forces on braking and the factors which affect stopping distances. The experiments using elastics, light gates and trolleys allow the opportunity to collect and analyse scientific data using ICT tools and the interpretation of the data using creative thought to develop theories. Work on stopping distances provides the opportunity to discuss how and why decisions about science and technology are made, including ethical issues and the social, economic and environmental effects of such decisions.

Suggested practical and research activities to select from	Assessable learning outcomes Foundation Tier only: low demand
<p>Use of elastics, light gates and trolleys to explore acceleration.</p>	<p>Recognise situations where forces cause things to:</p> <ul style="list-style-type: none"> <li>• speed up</li> <li>• slow down</li> <li>• stay at the same speed.</li> </ul> <p>Use the equation:</p> $\text{force} = \text{mass} \times \text{acceleration}$ <p>when given mass and acceleration.</p>
<p>Modelling stopping distances using a bicycle.</p> <p>Use of real car data from the Highway Code and websites or magazines to illustrate the science of stopping distances.</p> <p>Make a wall chart, PowerPoint presentation or a leaflet to show stopping distances for different speeds.</p>	<p>Describe thinking distance as:</p> <ul style="list-style-type: none"> <li>• the distance travelled between the need for braking occurring and the brakes starting to act.</li> </ul> <p>Describe braking distance as:</p> <ul style="list-style-type: none"> <li>• the distance taken to stop once the brakes have been applied.</li> </ul> <p>Describe stopping distance as:</p> <ul style="list-style-type: none"> <li>• thinking distance + braking distance.</li> </ul> <p>Calculate stopping distance given values for thinking distance and braking distance.</p> <p>Explain why thinking, braking and stopping distances are significant for road safety.</p>

### Module P3: Forces For Transport

#### Item P3c: Forces and motion

**Links to other items:** P3a: Speed, P3b: Changing speed, P3d: Work and power, P3e: Energy on the move, P3f: Crumple zones, P5d: Action and reaction

Assessable learning outcomes both tiers: standard demand	Assessable learning outcomes Higher Tier only: high demand
<p>Describe and interpret the relationship between force, mass and acceleration in everyday examples.</p> <p>Use the equation, including a change of subject:</p> $\text{force} = \text{mass} \times \text{acceleration}$	<p>Use the equation, including a change of subject and the need to previously calculate the accelerating force:</p> $\text{force} = \text{mass} \times \text{acceleration}$
<p>Explain how certain factors may increase thinking distance:</p> <ul style="list-style-type: none"> <li>• driver tiredness</li> <li>• influence of alcohol or other drugs</li> <li>• greater speed</li> <li>• distractions or lack of concentration.</li> </ul> <p>Explain how certain factors may increase braking distance:</p> <ul style="list-style-type: none"> <li>• road conditions</li> <li>• car conditions</li> <li>• greater speed.</li> </ul> <p>Interpret data about thinking distances and braking distances.</p> <p>Explain the implications of stopping distances in road safety:</p> <ul style="list-style-type: none"> <li>• driving too close to the car in front (i.e. inside thinking distance)</li> <li>• speed limits</li> <li>• road conditions.</li> </ul>	<p>Explain qualitatively everyday situations where braking distance is changed including:</p> <ul style="list-style-type: none"> <li>• friction</li> <li>• mass</li> <li>• speed</li> <li>• braking force.</li> </ul> <p>Draw and interpret the shapes of graphs for thinking and braking distance against speed.</p> <p>Explain the effects of increased speed on:</p> <ul style="list-style-type: none"> <li>• thinking distance – increases linearly</li> <li>• braking distance – increases as a squared relationship e.g. if speed doubles braking distance increases by a factor of four, if speed triples braking distance increases by a factor of nine.</li> </ul>

### Module P3: Forces For Transport

#### Item P3d: Work and power

**Summary:** Work is done whenever a force moves something. Transport, by its nature, is always moving and energy is being transferred all the time. In this item we will learn about power and the energy we use to provide it. Different power ratings, fuel consumption, engine size costs and associated environmental issues about car use can be used to develop the skills of presenting information, developing an argument and drawing a conclusion using scientific terms. This also provides the opportunity to discuss how scientific knowledge and ideas change over time.

Suggested practical and research activities to select from	Assessable learning outcomes Foundation Tier only: low demand
Construct a table of examples when work is, and is not, done.	Recall everyday examples in which work is done and power is developed to include: <ul style="list-style-type: none"> <li>• lifting weights</li> <li>• climbing stairs</li> <li>• pulling a sledge</li> <li>• pushing a shopping trolley.</li> </ul>
Measuring work done by candidates lifting weights, walking up stairs or doing 'step-ups'.	Describe how energy is transferred when work is done. Understand that the amount of work done depends on: <ul style="list-style-type: none"> <li>• the size of the force in newtons (N)</li> <li>• the distance travelled in metres (m).</li> </ul> Recall that the joule is the unit for both work and energy. Use the equation: $\text{work done} = \text{force} \times \text{distance}$
Measuring power developed by candidates lifting known weights or their body weight, up stairs for example. The plenary could focus on how efficient the human body is as a machine.	Describe power as a measurement of how quickly work is being done. Recall that power is measured in watts (W). Recognise that cars: <ul style="list-style-type: none"> <li>• have different power ratings</li> <li>• have different engine sizes</li> </ul> and these relate to fuel consumption.

### Module P3: Forces For Transport

#### Item P3d: Work and power

**Links to other items:** P3a: Speed, P3c: Forces and motion, P3e: Energy on the move, P3f: Crumple zones, P5d: Action and reaction

Assessable learning outcomes both tiers: standard demand	Assessable learning outcomes Higher Tier only: high demand
Use the equation: $\text{weight} = \text{mass} \times \text{gravitational field strength}$	Use the equation, including a change of subject: $\text{weight} = \text{mass} \times \text{gravitational field strength}$
Use the equation, including a change of subject: $\text{work done} = \text{force} \times \text{distance}$	Use the equation: $\text{work done} = \text{force} \times \text{distance}$ then use the value for work done in the power equation below.
Use the equation: $\text{power} = \frac{\text{work done}}{\text{time}}$  Interpret fuel consumption figures from data on cars to include: <ul style="list-style-type: none"> <li>• environmental issues</li> <li>• costs.</li> </ul>	Use the equation, including a change of subject: $\text{power} = \frac{\text{work done}}{\text{time}}$  when work has been calculated. Use and understand the derivation of the power equation in the form: $\text{power} = \text{force} \times \text{speed}$

### Module P3: Forces For Transport

#### Item P3e: Energy on the move

**Summary:** Transport is essential to modern life whether it be bus, train, tram, bicycle, walking or car. All these need a source of energy which is transferred to kinetic energy. Some vehicles use more fossil fuels than others and this has implications for cost, pollution in our cities and future energy reserves. Other vehicles may use bio-fuels or solar power which are renewable energy sources.

Suggested practical and research activities to select from	Assessable learning outcomes Foundation Tier only: low demand
Exploring the significance of KE in braking distances applied to stopping distance charts.	Understand that kinetic energy (KE) depends on the mass and speed of an object.
Carry out research to find out which energy sources can be used to move motor vehicles, and discover what proportion of vehicles use each source.	<p>Recognise and describe (derivatives of) fossil fuels as the main fuels in road transport:</p> <ul style="list-style-type: none"> <li>• petrol</li> <li>• diesel.</li> </ul> <p>Recall that bio-fuels and solar energy are possible alternatives to fossil fuels.</p> <p>Describe how electricity can be used for road transport, and how its use could affect different groups of people and the environment:</p> <ul style="list-style-type: none"> <li>• battery driven cars</li> <li>• solar power/cars with solar panels.</li> </ul>
Evaluating data from fuel consumption figures for cars. Construct a wall chart, make a PowerPoint presentation or a leaflet that illustrates the problems of large engine cars and the merits of solar power and bio-fuels.	<p>Draw conclusions from basic data about fuel consumption, including emissions (no recall required).</p> <p>Recognise that the shape of a moving object can influence its top speed and fuel consumption:</p> <ul style="list-style-type: none"> <li>• wedge shape of sports car</li> <li>• deflectors on lorries and caravans</li> <li>• roof boxes on cars</li> <li>• driving with car windows open.</li> </ul>

### Module P3: Forces For Transport

#### Item P3e: Energy on the move

**Links to other items:** P2a: Collecting energy from the Sun, P3f: Crumple zones, P3h: The energy of games and theme rides

Assessable learning outcomes both tiers: standard demand	Assessable learning outcomes Higher Tier only: high demand
Use and apply the equation: $KE = \frac{1}{2}mv^2$	Use and apply the equation: $KE = \frac{1}{2}mv^2$ including a change of subject.  Apply the ideas of kinetic energy to: <ul style="list-style-type: none"> <li>• relationship between braking distances and speed</li> <li>• everyday situations involving objects moving.</li> </ul>
Describe arguments for and against the use of battery powered cars.  Explain why electrically powered cars do not pollute at the point of use whereas fossil fuel cars do. Recognise that battery driven cars need to have the battery recharged: <ul style="list-style-type: none"> <li>• this uses electricity produced from a power station</li> <li>• power stations cause pollution.</li> </ul> Explain why we may have to rely on bio-fuelled and solar powered vehicles in the future.	Explain how bio-fuelled and solar powered vehicles: <ul style="list-style-type: none"> <li>• reduce pollution at the point of use</li> <li>• produce pollution in their production</li> <li>• may lead to an overall reduction in CO<sub>2</sub> emissions.</li> </ul>
Interpret data about fuel consumption, including emissions.	Explain how car fuel consumption figures depend on: <ul style="list-style-type: none"> <li>• energy required to increase KE</li> <li>• energy required to do work against friction</li> <li>• driving styles and speeds</li> <li>• road conditions.</li> </ul> Evaluate and compare data about fuel consumption and emissions.



### Module P3: Forces For Transport

#### Item P3f: Crumple zones

**Summary:** When cars stop energy is absorbed. This happens during braking and in collisions. Injuries in collisions can be reduced by clever car design and this unit explores the science behind the safety features of modern vehicles. Collisions are studied here in terms of energy, acceleration, force and momentum.

Suggested practical and research activities to select from	Assessable learning outcomes Foundation Tier only: low demand
	Use the equation: $\text{momentum} = \text{mass} \times \text{velocity}$ to calculate momentum.
Show videos on road safety and describe how seatbelts reduce the rate at which momentum changes.	Recall that a sudden change in momentum in a collision, results in a large force that can cause injury.
Design, build and test model crumple zones with trolleys, egg boxes, paper and straws.  Use road safety websites and booklets to find out about safety features of cars and how they are tested, compared, and reported to the public.  Test seatbelt materials for stretching.  Research safety features in modern cars.  Draw a time line showing when different safety features became standard on most cars.	Describe the typical safety features of modern cars that require energy to be absorbed when vehicles stop: <ul style="list-style-type: none"> <li>• heating in brakes, crumple zones, seatbelts, airbags.</li> </ul> Explain why seatbelts have to be replaced after a crash.  Recognise the risks and benefits arising from the use of seatbelts.  Recall and distinguish between typical safety features of cars which: <ul style="list-style-type: none"> <li>• are intended to prevent accidents, or</li> <li>• are intended to protect occupants in the event of an accident.</li> </ul>

### Module P3: Forces For Transport

#### Item P3f: Crumple zones

**Links to other items:** P3c: Forces and motion, P5d: Action and reaction

<b>Assessable learning outcomes both tiers: standard demand</b>	<b>Assessable learning outcomes Higher Tier only: high demand</b>
<p>Use the equation including a change of subject:  <math display="block">\text{momentum} = \text{mass} \times \text{velocity}</math>           Describe why the greater the mass of an object and/or the greater the velocity, the more momentum the object has in the direction of motion.</p> <p>Use the equation:  <math display="block">\text{force} = \frac{\text{change in momentum}}{\text{time}}</math>           to calculate force.</p>	<p>Use and apply the equation including a change of subject:  <math display="block">\text{force} = \frac{\text{change in momentum}}{\text{time}}</math></p> <p>Use Newton's second law of motion to explain the above points:  <math display="block">F = ma</math></p>
<p>Explain how spreading the change in momentum over a longer time reduces the likelihood of injury.</p> <p>Explain, using the ideas about momentum, the use of crumple zones, seatbelts and airbags in cars.</p>	<p>Explain why forces can be reduced when stopping (e.g. crumple zones, braking distances, escape lanes, crash barriers, seatbelts and airbags) by:</p> <ul style="list-style-type: none"> <li>• increasing stopping or collision time</li> <li>• increasing stopping or collision distance</li> <li>• decreasing acceleration.</li> </ul>
<p>Describe how seatbelts, crumple zones and airbags are useful in a crash because they:</p> <ul style="list-style-type: none"> <li>• change shape</li> <li>• absorb energy</li> <li>• reduce injuries.</li> </ul> <p>Describe how test data may be gathered and used to identify and develop safety features for cars.</p>	<p>Evaluate the effectiveness of given safety features in terms of saving lives and reducing injuries.</p> <p>Describe how ABS brakes:</p> <ul style="list-style-type: none"> <li>• make it possible to keep control of the steering of a vehicle in hazardous situations (e.g. when braking hard or going into a skid)</li> <li>• work by the brakes automatically pumping on and off to avoid skidding</li> <li>• sometimes reduce braking distances.</li> </ul> <p>Analyse personal and social choices in terms of risk and benefits of wearing seatbelts.</p>

### Module P3: Forces For Transport

#### Item P3g: Falling safely

**Summary:** Falling objects are usually subject to at least two forces - weight and drag. Some cars have similar engines to others yet have very different top speeds. This is to do with pairs of forces which may or may not balance. These ideas are of vital importance to the parachutist and drag-racer who want to slow down in time - safely! Investigating falling whirligig, parachutes or plasticine shapes provides the opportunity to explain phenomena by developing and using scientific theories. Work on the balance of forces illustrates the use of modelling in developing scientific understanding.

Suggested practical and research activities to select from	Assessable learning outcomes Foundation Tier only: low demand
<p>Investigate factors affecting the speed of a falling whirligig or parachute.</p> <p>Investigate factors affecting the speed of plasticine shapes as they fall through wall-paper paste.</p> <p>Use an electronic time device (e.g. light gates linked to a PC) to investigate falling objects.</p> <p>Make a wall chart by drawing a series of pictures of a falling parachutist to show the stages of flight for a sky-diver.</p>	<p>Recognise that frictional forces (drag, friction, air resistance):</p> <ul style="list-style-type: none"> <li>• act against the movement</li> <li>• lead to energy loss and inefficiency</li> <li>• can be reduced (shape, lubricant).</li> </ul> <p>Explain how objects falling through the Earth's atmosphere reach a terminal speed.</p>
	<p>Understand why falling objects do not experience drag when there is no atmosphere.</p>

### Module P3: Forces For Transport

#### Item P3g: Falling safely

**Links to other items:** P3h: The energy of games and theme rides, P5c: Projectile motion

<b>Assessable learning outcomes both tiers: standard demand</b>	<b>Assessable learning outcomes Higher Tier only: high demand</b>
<p>Explain in terms of the balance of forces how moving objects:</p> <ul style="list-style-type: none"> <li>• increase speed</li> <li>• decrease speed</li> <li>• maintain steady speed.</li> </ul>	<p>Explain, in terms of balance of forces, why objects reach a terminal speed:</p> <ul style="list-style-type: none"> <li>• higher speed = more drag</li> <li>• larger area = more drag</li> <li>• weight (falling object) or driving force (e.g. a car) = drag when travelling at terminal speed.</li> </ul>
<p>Recognise that acceleration due to gravity (<math>g</math>) is the same for any object at a given point on the Earth's surface.</p>	<p>Understand that gravitational field strength or acceleration due to gravity:</p> <ul style="list-style-type: none"> <li>• is unaffected by atmospheric changes</li> <li>• varies slightly at different points on the Earth's surface</li> <li>• will be slightly different on the top of a mountain or down a mineshaft.</li> </ul>

### Module P3: Forces For Transport

**Item P3h:** The energy of games and theme rides

**Summary:** Rides at theme parks are designed to thrill and frighten you in a safe way. We pay good money to have our 'gravity' distorted. Theme ride designers are experts on energy and forces. Their simple trick is to use gravity and potential energy as the source of movement. This item will help you understand the science of theme rides and how scientific understanding can be applied by society.

<b>Suggested practical and research activities to select from</b>	<b>Assessable learning outcomes Foundation Tier only: low demand</b>
Investigate bouncing balls (or a ball on a curved curtain track) as an energy system whose efficiency can be measured ( $100\% \times \text{bounce height (or height raised)}/\text{drop (or fall) height}$ ).	Recognise that objects have gravitational potential energy (GPE) because of their mass and position in Earth's gravitational field.
Investigate models (toy cars on plastic track) or real roller-coasters as an energy system whose efficiency can be measured ( $100\% \times \text{climb height}/\text{fall height}$ ).	Recognise everyday examples in which objects use gravitational potential energy (GPE).

### Module P3: Forces For Transport

**Item P3h:** The energy of games and theme rides

**Links to other items:** P3e: Energy on the move, P3g: Falling safely

<b>Assessable learning outcomes both tiers: standard demand</b>	<b>Assessable learning outcomes Higher Tier only: high demand</b>
<p>Describe everyday examples in which objects have gravitational potential energy (GPE).</p> <p>Use the equation:</p> $GPE = mgh$ <p>Recognise and interpret examples of energy transfer between gravitational potential energy (GPE) and kinetic energy (KE).</p>	<p>Understand that for a body falling through the atmosphere at terminal speed:</p> <ul style="list-style-type: none"> <li>kinetic energy (KE) does not increase</li> <li>gravitational potential energy (GPE) is transferred to increased internal or thermal energy of the surrounding air particles through the mechanism of friction.</li> </ul> <p>Use and apply the equation, including a change of subject:</p> $GPE = mgh$
<p>Interpret a gravity ride (roller-coaster) in terms of:</p> <ul style="list-style-type: none"> <li>kinetic energy (KE)</li> <li>gravitational potential energy (GPE)</li> <li>energy transfer.</li> </ul> <p>Describe the effect of changing mass and speed on kinetic energy (KE):</p> <ul style="list-style-type: none"> <li>doubling mass doubles KE</li> <li>doubling speed quadruples KE.</li> </ul>	<p>Use and apply the relationship</p> $mgh = \frac{1}{2}mv^2$ <p>Show that for a given object falling to Earth, this relationship can be expressed as</p> $h = v^2 \div 2g$ <p>and give an example of how this formula could be used.</p>

### 3.7 Module P4: Radiation For Life

#### Module P4: Radiation For Life

##### Item P4a: Sparks

**Summary:** The concept of medical physics runs through this item. Electrostatics plays an important part in our lives. We investigate some of the ideas of electrostatics and look at the problems caused.

Suggested practical and research activities to select from	Assessable learning outcomes Foundation Tier only: low demand
Carry out experiments to compare how effective different types of duster are.	Recognise that when some materials are rubbed they attract other objects: <ul style="list-style-type: none"> <li>• certain types of dusting brushes become charged and attract dust as they pass over it.</li> </ul>
Investigate the effect of charged insulators on small uncharged objects.  Carry out experiments to demonstrate the forces between charges.	Recognise that insulating materials can become charged when rubbed with another insulating material.  State that there are two kinds of charge: <ul style="list-style-type: none"> <li>• positive</li> <li>• negative.</li> </ul>
Carry out experiments to create static charges, and investigate the effects that result.	Describe how you can get an electrostatic shock from charged objects: <ul style="list-style-type: none"> <li>• synthetic clothing.</li> </ul> Describe how you can get an electrostatic shock if you become charged and then become earthed: <ul style="list-style-type: none"> <li>• touching water pipes after walking on a floor covered with an insulating material e.g. synthetic carpet.</li> </ul>

### Module P4: Radiation For Life

#### Item P4a: Sparks

**Links to other items:** P4b: Uses of electrostatics

Assessable learning outcomes both tiers: standard demand	Assessable learning outcomes Higher Tier only: high demand
<p>Recognise that like charges repel and unlike charges attract.</p> <p>Understand that electrostatic phenomena are caused by the transfer of electrons, which have a negative charge.</p>	<p>Describe static electricity in terms of the movement of electrons:</p> <ul style="list-style-type: none"> <li>• a positive charge due to lack of electrons</li> <li>• a negative charge due to an excess of electrons.</li> </ul> <p>Recognise that atoms or molecules that have become charged are ions.</p>
<p>Explain how static electricity can be dangerous when:</p> <ul style="list-style-type: none"> <li>• in atmospheres where explosions could occur e.g. inflammable gases or vapours or with high concentrations of oxygen</li> <li>• in situations where large quantities of charge could flow through the body to earth.</li> </ul> <p>Explain how static electricity can be a nuisance:</p> <ul style="list-style-type: none"> <li>• dirt and dust attracted to insulators (plastic containers, TV monitors etc.)</li> <li>• causing clothing to “cling”.</li> </ul>	<p>Explain how the chance of receiving an electric shock can be reduced by:</p> <ul style="list-style-type: none"> <li>• correct earthing</li> <li>• use of insulating mats</li> <li>• using shoes with insulating soles</li> <li>• bonding fuel tanker to aircraft.</li> </ul> <p>Explain how anti-static sprays, liquids and cloths help reduce the problems of static electricity.</p>



### Module P4: Radiation For Life

#### Item P4b: Uses of electrostatics

**Summary:** Electrostatics has many uses. This item looks at some of the uses both in medicine and everyday life and illustrates the use of contemporary scientific and technological developments and their benefits, drawbacks and risks.

Suggested practical and research activities to select from	Assessable learning outcomes Foundation Tier only: low demand
<p>Research how electrostatic precipitators work and how effective they are at reducing some pollution.</p>	<p>Recall that electrostatics can be useful for electrostatic precipitators:</p> <ul style="list-style-type: none"> <li>• remove the dust or soot in smoke</li> <li>• used in chimneys.</li> </ul>
	<p>Recall that electrostatics can be useful for spraying:</p> <ul style="list-style-type: none"> <li>• spray painting</li> <li>• crop spraying.</li> </ul>
<p>Research how defibrillators are used by medical staff in emergencies.</p>	<p>Recall that electrostatics can be useful for restarting the heart when it has stopped (defibrillator).</p> <p>Recall that defibrillators work by discharging charge.</p>

### Module P4: Radiation For Life

#### Item P4b: Uses of electrostatics

Links to other items: P4a: Sparks

<b>Assessable learning outcomes both tiers: standard demand</b>	<b>Assessable learning outcomes Higher Tier only: high demand</b>
<p>Explain how static electricity can be useful for electrostatic dust precipitators to remove smoke particles etc from chimneys:</p> <ul style="list-style-type: none"> <li>• dust passes through charged metal grid or past charged rods</li> <li>• dust particles become charged</li> <li>• plates are earthed or charged opposite to grid</li> <li>• dust particles attracted to plates</li> <li>• plates struck and dust falls to collector.</li> </ul>	<p>Explain how static electricity is used in electrostatic dust precipitators to remove smoke particles etc from chimneys:</p> <ul style="list-style-type: none"> <li>• high voltage metal grids put into chimneys to produce a charge on the dust</li> <li>• dust particles gain or lose electrons</li> <li>• dust particles induce a charge on the earthed metal plate</li> <li>• dust particles are attracted to the plates.</li> </ul>
<p>Explain how static electricity can be useful for paint spraying:</p> <ul style="list-style-type: none"> <li>• spray gun charged</li> <li>• paint particles charged the same so repel giving a fine spray and coat</li> <li>• object charged oppositely to paint so attracts paint into the 'shadows' of the object giving an even coat with less waste.</li> </ul>	<p>Explain how static electricity is used in paint spraying, in terms of paint and car gaining and losing electrons and the resulting effects.</p>
<p>Explain how static electricity can be useful for restarting the heart when it has stopped (defibrillator):</p> <ul style="list-style-type: none"> <li>• paddles charged</li> <li>• good electrical contact with patient's chest</li> <li>• charge passed through patient to make heart contract</li> <li>• care taken not to shock operator.</li> </ul>	

### Module P4: Radiation For Life

#### Item P4c: Safe electricals

**Summary:** This item investigates electricity. Safety is a major requirement when electricity is used in a medical situation. Here the principles of fuses and earthing are studied.

Suggested practical and research activities to select from	Assessable learning outcomes Foundation Tier only: low demand
<p>Carry out experiments to investigate circuits and the effects of resistors and variable resistors on current. Also the effects of length and thicknesses of resistance wire on current and resistance can be investigated.</p>	<p>Explain the behaviour of simple circuits in terms of the flow of electric charge.</p> <p>Describe and recognise how resistors can be used to change the current in a circuit.</p> <p>Describe how variable resistors can be used to change the current in a circuit:</p> <ul style="list-style-type: none"> <li>• longer wires give less current</li> <li>• thinner wires give less current</li> </ul> <p>(rheostat configured as a variable resistor only).</p> <p>Recall that resistance is measured in ohms.</p>
<p>Research house wiring features such as plugs and ring mains.</p>	<p>Recall the colour coding for live, neutral and earth wires:</p> <ul style="list-style-type: none"> <li>• live – brown</li> <li>• neutral – blue</li> <li>• earth – green/yellow.</li> </ul> <p>State that an earthed conductor cannot become live.</p>
<p>Investigate fuses and residual-current devices (RCDs) and research how they are used in the home.</p> <p>Compare a range of appliances to identify which are double insulated and what they have in common.</p> <p>Research and compare power and fuse ratings in common household appliances.</p> <p>A circus of appliances with plugs open and comparison of appliance coverings.</p>	<p>Describe reasons for the use of fuses and circuit breakers (as re-settable fuses).</p> <p>Recognise that “double insulated” appliances do not need earthing.</p>

## Module P4: Radiation For Life

### Item P4c: Safe electricals

Links to other items: P6a: Resisting

Assessable learning outcomes both tiers: standard demand	Assessable learning outcomes Higher Tier only: high demand
<p>Explain how variable resistors can be used to change the current in a circuit:</p> <ul style="list-style-type: none"> <li>longer wires have more resistance</li> <li>thinner wires have more resistance</li> </ul> <p>(rheostat configured as a variable resistor only).</p> <p>Describe the relationships between current, voltage (pd) and resistance:</p> <ul style="list-style-type: none"> <li>for a given resistor, current increases as voltage increases and vice versa</li> <li>for a fixed voltage, current decreases as resistance increases and vice versa.</li> </ul> <p>Use the equation:</p> $\text{resistance} = \frac{\text{voltage}}{\text{current}}$	<p>Use and apply the equation, including a change of subject:</p> $\text{resistance} = \frac{\text{voltage}}{\text{current}}$
<p>Describe the functions of the live, neutral and earth wires:</p> <ul style="list-style-type: none"> <li>live – carries the high voltage</li> <li>neutral – completes the circuit</li> <li>earth – a safety wire to stop the appliance becoming live.</li> </ul>	
<p>Explain how a wire fuse reduces the risk of fire; if the appliance develops a fault:</p> <ul style="list-style-type: none"> <li>too large a current causes the fuse to melt</li> <li>preventing flow of current</li> <li>prevents flex overheating and causing fire</li> <li>prevents further damage to appliance.</li> </ul> <p>Use the equation:</p> $\text{power} = \text{voltage} \times \text{current}$ <p>Explain why “double insulated” appliances do not need earthing:</p> <ul style="list-style-type: none"> <li>the appliance is a non conductor and cannot become live.</li> </ul>	<p>Explain the reasons for the use of fuses and circuit breakers as re-settable fuses (structure and mode of operation not required).</p> <p>Explain how the combination of a wire fuse and earthing protects people.</p> <p>Use the equation, including a change of subject:</p> $\text{power} = \text{voltage} \times \text{current}$ <p>to select a suitable fuse for an appliance.</p>

### Module P4: Radiation For Life

#### Item P4d: Ultrasound

**Summary:** The concept of medical physics runs through this item. Ultrasound is an important medical diagnostic and therapeutic tool. This item looks at the properties of longitudinal waves, and investigates some of the medical uses of ultrasound.

Suggested practical and research activities to select from	Assessable learning outcomes Foundation Tier only: low demand
<p>Look at ultrasound pictures and investigate the hearing range of pupils in the class.</p> <p>Investigate the properties of longitudinal waves.</p> <p>Use a slinky and/or rope to demonstrate wave behaviours.</p>	<p>Recall that ultrasound is a longitudinal wave. Recognise features of a longitudinal wave:</p> <ul style="list-style-type: none"> <li>• wavelength</li> <li>• compression</li> <li>• rarefaction.</li> </ul>
<p>Use echoes from hard surfaces to develop the idea of reflection of sound, and calculation of distance to the surface (using the echo time and speed of sound).</p>	<p>Recognise that ultrasound can be used in medicine for diagnostic purposes:</p> <ul style="list-style-type: none"> <li>• to look inside people by scanning the body</li> <li>• to measure the speed of blood flow in the body (candidates are not expected to describe the Doppler effect).</li> </ul>

## Module P4: Radiation For Life

### Item P4d: Ultrasound

**Links to other items:** P1d: Light and lasers

<b>Assessable learning outcomes both tiers: standard demand</b>	<b>Assessable learning outcomes Higher Tier only: high demand</b>
<p>Describe features of longitudinal waves:</p> <ul style="list-style-type: none"> <li>• wavelength</li> <li>• frequency</li> <li>• compression (a region of higher pressure)</li> <li>• rarefaction (a region of lower pressure).</li> </ul> <p>Recall that the frequency of ultrasound is higher than the upper threshold of human hearing (20 000 Hz) because the ear cannot detect these very high frequencies.</p>	<p>Describe and compare the motion and arrangement of particles in longitudinal and transverse physical waves:</p> <ul style="list-style-type: none"> <li>• wavelength</li> <li>• frequency</li> <li>• compression</li> <li>• rarefaction</li> <li>• amplitude.</li> </ul>
<p>Recognise that ultrasound can be used in medicine for non-invasive therapeutic purposes such as to break down kidney and other stones.</p>	<p>Explain how ultrasound is used in:</p> <ul style="list-style-type: none"> <li>• body scans (reflections from different layers returning at different times from different depths)</li> <li>• breaking down accumulations in the body such as kidney stones.</li> </ul> <p>Explain the reasons for using ultrasound rather than X-rays for certain scans:</p> <ul style="list-style-type: none"> <li>• able to produce images of soft tissue</li> <li>• does not damage living cells.</li> </ul>

**Module P4: Radiation For Life****Item P4e: What is radioactivity?**

**Summary:** Nuclear radiation is often misunderstood and frightening. Many people will come across nuclear radiations in everyday life. This item explores the properties and uses of nuclear radiation.

<b>Suggested practical and research activities to select from</b>	<b>Assessable learning outcomes Foundation Tier only: low demand</b>
<p>Investigate the reality of long half-lives and the dangers of nuclear waste.</p> <p>Explore the idea of half-life and how it is used to date artefacts in archaeology and rocks containing radioactive minerals.</p> <p>Model radioactive decay with dice or computer simulations.</p>	<p>Recognise that the radioactivity or activity of an object is measured by the number of nuclear decays emitted per second.</p> <p>Understand that radioactivity decreases with time.</p> <p>Recall that nuclear radiation ionises materials.</p>
<p>Use the Periodic Table to construct a graph of proton number against neutron number to show line of stability.</p>	<p>Recall that radiation comes from the nucleus of the atom.</p>

### Module P4: Radiation For Life

**Item P4e:** What is radioactivity?

**Links to other items:** P2e: Nuclear radiations, P4f: Uses of radioisotopes, P4g: Treatment, P4h: Fission and fusion

<b>Assessable learning outcomes both tiers: standard demand</b>	<b>Assessable learning outcomes Higher Tier only: high demand</b>
<p>Describe radioactive substances as decaying naturally and giving out nuclear radiation in the form of alpha, beta and gamma.</p> <p>Explain and use the concept of half-life.</p> <p>Interpret graphical data of radioactive decay to include a qualitative description of half-life.</p> <p>Explain ionisation in terms of:</p> <ul style="list-style-type: none"> <li>• removal of electrons from particles</li> <li>• gain of electrons by particles.</li> </ul>	<p>Interpret graphical or numerical data of radioactive decay to include calculation of half-life.</p> <p>Explain why alpha particles are such good ionisers.</p>
<p>Describe radioactivity as coming from the nucleus of an atom that is unstable.</p> <p>Recall that an alpha particle is a helium nucleus.</p> <p>Recall that a beta particle is a fast moving electron.</p>	<p>Describe what happens to a nucleus when an alpha particle is emitted:</p> <ul style="list-style-type: none"> <li>• mass number decreases by 4</li> <li>• nucleus has two fewer neutrons</li> <li>• nucleus has two fewer protons</li> <li>• atomic number decreases by 2</li> <li>• new element formed.</li> </ul> <p>Describe what happens to a nucleus when a beta particle is emitted:</p> <ul style="list-style-type: none"> <li>• mass number is unchanged</li> <li>• nucleus has one less neutron</li> <li>• nucleus has one more proton</li> <li>• atomic number increases by one</li> <li>• new element formed.</li> </ul> <p>Construct and balance nuclear equations in terms of mass numbers and atomic numbers to represent alpha and beta decay.</p>



### Module P4: Radiation For Life

#### Item P4f: Uses of radioisotopes

**Summary:** The uses of radioisotopes include tracers, smoke alarms, cancer treatment and radioactive dating. This item illustrates the use of contemporary scientific and technological developments and their benefits, drawback and risks. It also provides the opportunity to use ICT in teaching and learning, while work on dating rocks illustrates how ICT is used by scientists.

<b>Suggested practical and research activities to select from</b>	<b>Assessable learning outcomes Foundation Tier only: low demand</b>
<p>Research and debate the issues surrounding the storage and disposal of radioactive waste.</p> <p>Use the internet to research levels of background radiation in different parts of the UK.</p> <p>Investigate the variation of background radiation with location and possible health risks.</p>	<p>Understand why background radiation can vary.</p> <p>Recall that background radiation mainly comes from rocks and cosmic rays.</p>
<p>Research the use of radioisotopes in industry.</p>	<p>Recall industrial examples of the use of tracers:</p> <ul style="list-style-type: none"> <li>• to track dispersal of waste</li> <li>• to find leaks/blockages in underground pipes</li> <li>• to find the route of underground pipes.</li> </ul>
<p>Look inside ionisation based smoke detectors and identify the relevant parts.</p>	<p>Recall that alpha sources are used in some smoke detectors.</p>
	<p>Recall that radioactivity can be used to date rocks.</p>

### Module P4: Radiation For Life

**Item P4f:** Uses of radioisotopes

**Links to other items:** P2e: Nuclear radiations, P4e: What is radioactivity?, P4h: Fission and fusion

Assessable learning outcomes both tiers: standard demand	Assessable learning outcomes Higher Tier only: high demand
Recall that some background radiation comes from waste products and man-made sources e.g. waste from: <ul style="list-style-type: none"> <li>• industry</li> <li>• hospitals.</li> </ul>	Evaluate the relative significance of sources of background radiation.
Describe how tracers are used in industry: <ul style="list-style-type: none"> <li>• radioactive material put into pipe</li> <li>• progress tracked with detector above ground/ outside pipe</li> <li>• leak/blockage shown by reduction/no radioactivity after the point of blockage.</li> </ul>	Explain why gamma radiation is used as an industrial tracer.
Explain how a smoke detector with an alpha source works: <ul style="list-style-type: none"> <li>• smoke particles hit by alpha radiation</li> <li>• less ionisation of air particles</li> <li>• current is reduced causing alarm to sound.</li> </ul>	
Explain how the radioactive dating of rocks depends on the calculation of the uranium/lead ratio. Recall that measurements from radioactive carbon can be used to find the date of old materials.	Explain how measurements of the activity of radioactive carbon can lead to an approximate age for different materials: <ul style="list-style-type: none"> <li>• the amount of Carbon-14 in the air has not changed for thousands of years</li> <li>• when an object dies (e.g. wood) gaseous exchange with the air stops</li> <li>• as the Carbon-14 in the wood decays the activity of the sample decreases</li> <li>• the ratio of current activity from living matter to the activity of the sample is used to calculate the age within known limits.</li> </ul>

### Module P4: Radiation For Life

#### Item P4g: Treatment

**Summary:** The concept of medical physics runs through this item. Radiations are important medicinal tools. This item looks at the use of radiations and the precautions taken to reduce the potential risks.

Suggested practical and research activities to select from	Assessable learning outcomes Foundation Tier only: low demand
<p>Look at X-ray images and research how they are produced.</p>	<p>Describe some similarities and differences between X-rays and gamma rays:</p> <ul style="list-style-type: none"> <li>• both are ionising electromagnetic waves</li> <li>• have similar wavelengths</li> <li>• are produced in different ways.</li> </ul>
<p>Research the production of medical radioisotopes.</p>	<p>Recall that medical radioisotopes are produced by placing materials into a nuclear reactor.</p>
<p>Demonstrate and model the tracer idea with a radioactive source (low level sample (e.g. rock) only) hidden in school skeleton and detected outside.</p> <p>Investigate the balance of risks for staff and patients during radiotherapy which kills both healthy and cancerous cells.</p>	<p>Describe uses of nuclear radiation in medicine, to include:</p> <ul style="list-style-type: none"> <li>• diagnosis</li> <li>• treatment of cancer using gamma rays</li> <li>• sterilisation of equipment.</li> </ul> <p>Recall that only beta and gamma radiation can pass through skin.</p> <p>Recall that nuclear radiation can damage cells.</p> <p>Describe the role of a radiographer and the safety precautions they must take.</p>

### Module P4: Radiation For Life

#### Item P4g: Treatment

**Links to other items:** P2e: Nuclear radiations, P4e: What is radioactivity?

<b>Assessable learning outcomes both tiers: standard demand</b>	<b>Assessable learning outcomes Higher Tier only: high demand</b>
<p>Recall that materials absorb some ionising radiation.</p> <p>Understand how the image produced by the absorption of X-rays depends on the thickness and density of the absorbing materials.</p>	<p>Explain how:</p> <ul style="list-style-type: none"> <li>• gamma rays are given out: from the nucleus of certain radioactive materials</li> <li>• X-rays are made: by firing high speed electrons at metal targets</li> <li>• X-rays are easier to control than gamma rays.</li> </ul>
<p>Describe how materials can become radioactive as a result of absorbing extra neutrons.</p>	
<p>Explain why gamma (and sometimes beta) emitters can be used as tracers in the body.</p> <p>Understand why medical tracers should not remain active in the body for long periods.</p>	<p>Explain how radioactive sources are used in medicine:</p> <ol style="list-style-type: none"> <li>1. to treat cancer: <ul style="list-style-type: none"> <li>• gamma rays focused on tumour</li> <li>• wide beam used</li> <li>• rotated round the patient with tumour at centre</li> <li>• limiting damage to non-cancerous tissue.</li> </ul> </li> <li>2. as a tracer: <ul style="list-style-type: none"> <li>• beta or gamma emitter with a short half life</li> <li>• drunk/eaten/ingested/injected into the body</li> <li>• allowed to spread through the body</li> <li>• followed on the outside by a radiation detector.</li> </ul> </li> </ol>

### Module P4: Radiation For Life

#### Item P4h: Fission and fusion

**Summary:** This item deals with work on the processes of nuclear fission and fusion. Nuclear fission is a major source of energy and can be used to produce electricity. Oil and gas will become less important as supplies decrease and alternative forms of energy will be needed. This item explains the process of nuclear fission and how the energy produced can be harnessed to produce electricity. The prospect of harnessing nuclear fusion for power generation is also considered.

Suggested practical and research activities to select from	Assessable learning outcomes Foundation Tier only: low demand
Use ICT simulations of chain reactions and nuclear reactors.	Recognise that nuclear power stations use uranium as a fuel.  Describe the main stages in the production of electricity: <ul style="list-style-type: none"> <li>• source of energy</li> <li>• used to produce steam</li> <li>• used to produce electricity.</li> </ul>
Research nuclear accidents in power plants.  Debate the issues surrounding nuclear power as a solution to future UK needs.	Describe the process that gives out energy in a nuclear reactor as nuclear fission, and that it is kept under control.  Recall that nuclear fission produces radioactive waste.
Investigate potential benefits and difficulties of developing fusion based nuclear reactors.	Describe the difference between fission and fusion: <ul style="list-style-type: none"> <li>• fission is the splitting of nuclei</li> <li>• fusion is the joining of nuclei.</li> </ul>
Investigate 'Cold Fusion' controversy ( <i>Fleischmann–Pons claims</i> ) as an example of the development of theories and the peer review process.	Recall that one group of scientists have claimed to successfully achieve 'cold fusion'.  Explain why the claims are disputed: other scientists could not repeat their findings.

### Module P4: Radiation For Life

#### Item P4h: Fission and fusion

**Links to other items:** P2b: Generating electricity, P2d: Fuels for power, P4e: What is radioactivity?, P4f: Uses of radioisotopes

Assessable learning outcomes both tiers: standard demand	Assessable learning outcomes Higher Tier only: high demand
<p>Describe how domestic electricity is generated at a nuclear power station:</p> <ul style="list-style-type: none"> <li>nuclear reaction</li> <li>producing heat</li> <li>heating water to produce steam</li> <li>spinning a turbine</li> <li>driving a generator.</li> </ul>	<p>Describe what happens to allow uranium to release energy:</p> <ul style="list-style-type: none"> <li>uranium nucleus hit by neutron</li> <li>causes nucleus to split</li> <li>energy released</li> <li>more neutrons released.</li> </ul>
<p>Understand how the decay of uranium starts a chain reaction.</p> <p>Describe a nuclear bomb as a chain reaction that has gone out of control.</p>	<p>Explain what is meant by a chain reaction:</p> <ul style="list-style-type: none"> <li>when each uranium nucleus splits more than one neutron is given out</li> <li>these neutrons can cause further uranium nuclei to split.</li> </ul> <p>Explain how scientists stop nuclear reactions going out of control:</p> <ul style="list-style-type: none"> <li>rods placed in the reactor</li> <li>to absorb some of the neutrons</li> <li>allowing enough neutrons to remain to keep the process operating.</li> </ul>
<p>Describe how nuclear fusion releases energy:</p> <ul style="list-style-type: none"> <li>fusion happens when two nuclei join together</li> <li>fusion produces large amounts of heat energy</li> <li>fusion happens at extremely high temperatures.</li> </ul> <p>Describe why fusion for power generation is difficult:</p> <ul style="list-style-type: none"> <li>requires extremely high temperatures</li> <li>high temperatures have to be safely managed.</li> </ul> <p>Understand why fusion power research is carried out as an international joint venture.</p>	<p>Explain how different isotopes of hydrogen can undergo fusion to form helium:</p> ${}^1_1\text{H} + {}^2_1\text{H} \rightarrow {}^3_2\text{He}$ <p>Understand the conditions needed for fusion to take place, to include:</p> <ul style="list-style-type: none"> <li>in stars, fusion happens under extremely high temperatures and pressures</li> <li>fusion bombs are started with a fission reaction which creates exceptionally high temperatures</li> <li>for power generation exceptionally high temperatures and/or pressures are required and this combination offers (to date) safety and practical challenges.</li> </ul>
<p>Explain why the 'cold fusion' experiments and data have been shared between scientists.</p>	<p>Explain why 'cold fusion' is still not accepted as a realistic method of energy production.</p>

### 3.8 Module P5: Space For Reflection

#### Module P5: Space For Reflection

##### Item P5a: Satellites, gravity and circular motion

**Summary:** Satellites have played a major part in the global communications revolution. We can call someone on the other side of the world using a mobile phone or watch events around the world, as they happen, in the comfort of our own homes. This item looks at what satellites are, their uses, including communications and satellite TV, and the physics behind what keeps them in the correct orbit. Newton's experiment illustrates how uncertainties about science ideas change over time, and the use of models to explain phenomena.

Suggested practical and research activities to select from	Assessable learning outcomes Foundation Tier only: low demand
<p>Observe the International Space Station moving across the sky. Use the internet (e.g. NASA website) for information on the International Space Station and Space Shuttle.</p>	<p>Recall that gravity is the universal force of attraction between masses.</p> <p>Recognise that a satellite is an object that orbits a larger object in space.</p> <p>Describe the difference between artificial and natural satellites.</p>
<p>Use the internet to find images of the Earth taken by satellites. (Use images recorded in other wavelengths as well as visible light).</p> <p>Demonstration of circular motion by swinging a bung around with masses pulling it down. A glass tube is needed to thread the wire through and to hold as you rotate the bung.</p> <p>Demonstration of unbalanced force using a record player to show objects 'flying off' when the speed is high enough.</p>	<p>Describe how the height above the Earth's surface affects the orbit of an artificial satellite.</p> <p>Recall how the height of orbit of an artificial satellite determines its use.</p>
<p>Describe Newton's thought experiment regarding a cannonball fired from a high mountain which, at a high enough speed, will orbit the Earth.</p>	<p>Recall some of the applications of artificial satellites to include:</p> <ul style="list-style-type: none"> <li>• communications</li> <li>• weather forecasting</li> <li>• military uses</li> <li>• scientific research</li> <li>• GPS</li> <li>• imaging the earth.</li> </ul>

**Module P5: Space For Reflection****Item P5a:** Satellites, gravity and circular motion**Links to other items:** P3b: Changing speed, P3c: Forces and motion

<b>Assessable learning outcomes both tiers: standard demand</b>	<b>Assessable learning outcomes Higher Tier only: high demand</b>
<p>Explain why the Moon remains in orbit around the Earth and the Earth and other planets in orbit around the Sun.</p>	<p>Describe the variation of gravitational force with distance (idea of inverse square law).</p> <p>Explain the variation in speed of a periodic comet during its orbit around the Sun to include:</p> <ul style="list-style-type: none"> <li>• influence of highly elliptical orbit</li> <li>• variation in gravitational force of attraction.</li> </ul> <p>Explain how the orbital period of a planet depends upon its distance from the Sun.</p>
<p>Describe the orbit of a geostationary artificial satellite:</p> <ul style="list-style-type: none"> <li>• orbits the Earth once in 24 hours around the equator</li> <li>• remains in a fixed position above the Earth's surface</li> <li>• orbits above the Earth's equator.</li> </ul> <p>Understand that circular motion requires:</p> <ul style="list-style-type: none"> <li>• a centripetal force</li> <li>• gravity provides the centripetal force for orbital motion.</li> </ul>	<p>Understand that artificial satellites are continually accelerating towards the Earth due to the Earth's gravitational pull, but that their tangential motion keeps them moving in an approximately circular orbit.</p>
<p>Explain why different satellite applications require different orbits, to include the orbit's:</p> <ul style="list-style-type: none"> <li>• height</li> <li>• period</li> <li>• trajectory (including polar orbit).</li> </ul>	<p>Explain why artificial satellites in lower orbits travel faster than those in higher orbits.</p>



### Module P5: Space For Reflection

#### Item P5b: Vectors and equations of motion

**Summary:** When analysing the motion of objects, knowing how fast they are travelling is only half the information. We also need to know the direction that they are travelling in. Two cars travelling towards each other at high speed is entirely different from the same cars travelling at the same speed in the same direction.

Suggested practical and research activities to select from	Assessable learning outcomes Foundation Tier only: low demand
	<p>Recall that direction is important when describing the motion of an object.</p> <p>Understand how relative speed depends on the direction of movement (in context of two cars travelling on a straight road).</p>
<p>Measure the average speed of an object moving in a straight line, horizontally or falling under gravity.</p> <p>Use electronic equipment (light gates interfaced with a PC) to measure speed and acceleration.</p> <p>Use an electronic or electrical method together with an equation of motion to calculate the acceleration due to gravity.</p>	<p>Recall that:</p> <ul style="list-style-type: none"> <li>direction is not important when measuring speed</li> <li>speed is a scalar quantity.</li> </ul> <p>Recognise that for any journey:</p> <ul style="list-style-type: none"> <li>distance travelled can be calculated using the equation:</li> </ul> $\text{distance} = \text{average speed} \times \text{time}$ $s = \frac{(u + v)}{2} \times t$ <p>Use the equation:</p> $v = u + at$ <p>to calculate final speed only.</p>

### Module P5: Space For Reflection

**Item P5b:** Vectors and equations of motion

**Links to other items:** P3a: Speed, P3b: Changing speed

Assessable learning outcomes both tiers: standard demand	Assessable learning outcomes Higher Tier only: high demand
<p>Describe the difference between scalar and vector quantities:</p> <ul style="list-style-type: none"> <li>• some quantities, (e.g. mass, time), direction is not relevant (scalar)</li> <li>• some quantities, (e.g. force, velocity, acceleration) direction is important (vector).</li> </ul> <p>Calculate the vector sum from vector diagrams of parallel vectors (limited to force and velocity in the same or opposite directions).</p>	<p>Calculate the resultant of two vectors that are at right angles to each other. (Answers can be by calculation or scale diagram).</p>
<p>Use the equation:</p> $v = u + at$ <p>to calculate v or u.</p> <p>Use the equation, including a change of subject:</p> $s = \frac{(u + v)}{2} \times t$	<p>Use the equations, including a change of subject:</p> $v^2 = u^2 + 2as$ $s = ut + \frac{1}{2} at^2$

### Module P5: Space For Reflection

#### Item P5c: Projectile motion

**Summary:** Many sports involve throwing, striking or kicking a ball. We are more than familiar with the path taken by a ball that is thrown to us, yet to have our hands in the right position to catch it, requires our brain to analyse the situation very quickly. The shape of the path or 'trajectory' together with the calculations behind this are considered here. Trajectories taken by golf balls and cricket balls can be illustrated by using ICT for teaching and learning. The 'pearls in the air' demonstration provides experience of scientific models.

Suggested practical and research activities to select from	Assessable learning outcomes Foundation Tier only: low demand
<p>Use TV images of golfers or footballers to show that the trajectories taken by golf balls and footballs are parabolic (many broadcasts now show the trajectory of the ball).</p> <p>Show "pearls in air" demonstration to show parabolic trajectory.</p>	<p>Recall and identify that the path of an object projected horizontally in the Earth's gravitational field is curved.</p> <p>Recall that the path of a projectile is called the trajectory.</p>
<p>Use 'horizontal and vertical' projectile apparatus to show the independence of the two.</p> <p>Show video clips of stroboscopic motion of falling objects and bouncing balls.</p>	<p>Recognise examples of projectile motion in a range of contexts.</p>
<p>Collect information from the internet and make a PowerPoint presentation about how the launch angle can affect the range of a ball.</p>	<p>Recall that the range of a ball struck in sport depends on the launch angle, with an optimum angle of <math>45^\circ</math>.</p>

### Module P5: Space For Reflection

**Item P5c:** Projectile motion

**Links to other items:** P3g: Falling safely

<b>Assessable learning outcomes both tiers: standard demand</b>	<b>Assessable learning outcomes Higher Tier only: high demand</b>
<p>Describe the trajectory of an object projected in the Earth's gravitational field as parabolic.</p> <p>Recall that the horizontal and vertical velocities of a projectile are vectors.</p>	<p>Understand that the resultant velocity of a projectile is the vector sum of the horizontal and vertical velocities.</p>
<p>Recall that for a projectile in Earth's gravitational field, ignoring air resistance</p> <ul style="list-style-type: none"> <li>• there is no acceleration in the horizontal direction (a constant horizontal velocity)</li> <li>• the acceleration due to gravity acts in the vertical direction (steadily increasing vertical velocity).</li> </ul>	<p>Use the equations of motion (in Item P5b) for an object projected horizontally above the Earth's surface where the gravitational field is still uniform.</p>
<p>Recall that, other than air resistance, the only force acting on a ball during flight is gravity.</p> <p>Understand that projectiles have a downward acceleration and that this only affects the vertical velocity.</p> <p>Interpret data on the range of projectiles at different launch angles.</p>	<p>Explain how for an object projected horizontally:</p> <ul style="list-style-type: none"> <li>• the horizontal velocity is unaffected by gravity</li> <li>• therefore the horizontal velocity is constant</li> <li>• gravity causes the vertical velocity to change.</li> </ul>

### Module P5: Space For Reflection

#### Item P5d: Action and reaction

**Summary:** Coming to a sudden stop is far more painful and dangerous than stopping gently. Seatbelts and crumple zones in cars are designed to bring people and moving objects to rest slowly and safely. People falling from a burning building are caught in a 'Fireman's Blanket' for the same reasons. Even objects with a small mass can have a lot of momentum when struck hard and given a high velocity, and even individual atoms can contribute momentum to launch a powerful rocket, if there are a large enough number of atoms involved.

Suggested practical and research activities to select from	Assessable learning outcomes Foundation Tier only: low demand
<p>Use skateboards, chairs on wheels, dynamics trolleys or magnets to show the effect of equal and opposite forces.</p> <p>Carry out a demonstration using air tracks or trolleys to illustrate the conservation of momentum.</p>	<p>Describe and recognise that every action has an equal and opposite reaction.</p>
<p>Discuss examples of collisions in sport (e.g. striking a ball with a bat)</p>	<p>Describe and recognise the opposite reactions in a parallel collision (i.e. velocities parallel).</p> <p>Recall everyday examples of collisions; to include sporting examples and car collisions.</p>
	<p>Explain, using a particle model, how a gas exerts a pressure on the walls of its container.</p>
<p>Launch a water rocket to demonstrate that the explosion propels the water down with the same momentum as the rocket shoots up.</p> <p>Compare mass of fuel and mass of rockets for commercial rocket systems.</p> <p>Research the use of ion motors for deep space probes.</p>	<p>Recall that in a rocket, the force pushing the particles backwards equals the force pushing the rocket forwards.</p>

### Module P5: Space For Reflection

**Item P5d:** Action and reaction

**Links to other items:** P3f: Crumple zones

<b>Assessable learning outcomes both tiers: standard demand</b>	<b>Assessable learning outcomes Higher Tier only: high demand</b>
<p>Understand that when an object collides with another object or two bodies interact, the two objects exert an equal and opposite force on each other. (Newton's third law of motion).</p>	
<p>Describe the opposite reactions in a number of static situations including examples involving gravity.</p> <p>Understand that equal but opposite forces act in a collision and use this to explain the change in motion of the objects, to include recoil.</p>	<p>Understand that momentum is a property that is always conserved and use that to explain:</p> <ul style="list-style-type: none"> <li>• explosions</li> <li>• recoil</li> <li>• rocket propulsion.</li> </ul> <p>Apply the principle of conservation of momentum to collisions of two objects moving in the same direction (including calculation of mass, speed or momentum only) for collisions when the colliding objects coalesce using the equation</p> $m_1 u_1 + m_2 u_2 = (m_1 + m_2)v$
<p>Explain, using a particle model, how a change in volume or temperature produces a change in pressure.</p>	<p>Explain pressure in terms of</p> <ul style="list-style-type: none"> <li>• the change of momentum of the particles striking the walls creating a force</li> <li>• the frequency of collisions.</li> </ul>
<p>Explain, using kinetic theory, rocket propulsion in terms of fast moving particles colliding with rocket walls creating a force.</p>	<p>Explain how, for large scale rockets used to lift satellites into the Earth's orbit, sufficient force is created to lift the rocket:</p> <ul style="list-style-type: none"> <li>• a large number of particles of exhaust gas are needed</li> <li>• the particles must be moving at high speeds.</li> </ul>

### Module P5: Space For Reflection

#### Item P5e: Satellite communication

**Summary:** Using microwave and satellite technology, you can call anyone from anywhere on the planet, or receive a TV signal via a satellite dish. This technology has moved at a rapid pace. But how does the signal from our mobile phones get to the person receiving the call and how do TV and radio broadcasts reach the viewer and listener? This item looks at why we use microwaves to transmit information and the physics behind the communications industry.

Suggested practical and research activities to select from	Assessable learning outcomes Foundation Tier only: low demand
<p>Use the internet to research the parts of the Earth's atmosphere and their effects on absorbing or transmitting electromagnetic radiation.</p> <p>Predict the location of a satellite sending digital TV signals to Earth by looking at which direction the satellite dishes are all pointing in a street of houses.</p>	<p>Recall that different frequencies are used for low orbit satellites (relatively lower frequency) and geostationary satellites (relatively higher frequency).</p>
<p>Show that mobile phones give off electromagnetic waves by placing them near loudspeakers and listening for the crackle.</p> <p>Examine pictures of waves coming into harbours.</p>	<p>Recall that some radio waves (e.g. long wavelength) are reflected by part of the Earth's upper atmosphere.</p> <p>Recall that some radio waves (e.g. short wavelength) and microwaves pass through the Earth's atmosphere.</p>
<p>Use ripple tanks or microwave kits to show that waves spread out from a gap.</p> <p>Demonstration of single edge diffraction using a laser beam.</p>	<p>Recall that radio waves have a very long wavelength.</p> <p>Recognise that radio waves can 'spread' around large objects.</p> <p>Describe a practical example of waves spreading out from a gap.</p>

### Module P5: Space For Reflection

#### Item P5e: Satellite communication

**Links to other items:** P1c: A spectrum of waves, P1g: Wireless signals

<b>Assessable learning outcomes both tiers: standard demand</b>	<b>Assessable learning outcomes Higher Tier only: high demand</b>
<p>Describe how information can be transmitted using microwaves to orbiting artificial satellites and then retransmitted back to Earth or to other satellites.</p> <p>Explain why satellite communication uses digital signals.</p>	<p>Explain why satellite transmitting and receiving dishes need very careful alignment:</p> <ul style="list-style-type: none"> <li>• the size of a satellite communication dish is many times the microwave wavelength</li> <li>• this produces little diffraction hence a narrow beam that does not spread out</li> <li>• this means the receiving dish and satellite dish need exact alignment.</li> </ul>
<p>Describe how electromagnetic waves with different frequencies behave in the atmosphere:</p> <ul style="list-style-type: none"> <li>• below 30 MHz are reflected by the ionosphere</li> <li>• above 30 GHz, rain, dust and other atmospheric effects reduce the strength of the signal due to absorption and scattering</li> <li>• between 30 MHz and 30 GHz can pass through the Earth's atmosphere.</li> </ul>	
<p>Recall the wave patterns produced by a plane wave passing through different sized gaps.</p> <p>Explain why long wave radio waves have a very long range.</p>	<p>Describe how the amount of diffraction depends upon the size of the gap and the wavelength of the wave, including the conditions for maximum diffraction.</p>



### Module P5: Space For Reflection

#### Item P5f: Nature of waves

**Summary:** Particles can behave like waves. At other times waves behave like particles. The nature of waves and the interaction of particles is fundamental to our understanding of the world around us. This item looks at the most important of all wave properties – interference. When people talk about interference they usually mean ‘noise’ in an electronic system or ‘crackle’ in a radio receiver. In the topic of waves, interference means the effect produced when two waves meet and interact with each other.

Suggested practical and research activities to select from	Assessable learning outcomes Foundation Tier only: low demand
<p>Carry out a demonstration to show the interference of waves using a ripple tank.</p> <p>Listen to interference by placing two speakers 1m apart and playing the same note. Pupils will notice the loud and quiet spots.</p> <p>Look at waves down a slinky and see what happens when two waves travelling in opposite directions interfere with each other.</p>	<p>Describe interference as an effect resulting from two waves that overlap.</p> <p>Recognise that when waves overlap there are:</p> <ul style="list-style-type: none"> <li>• areas where the waves add together</li> <li>• areas where the waves subtract from each other.</li> </ul> <p>Describe the effect of interference on waves in different contexts, to include:</p> <ul style="list-style-type: none"> <li>• sound</li> <li>• light</li> <li>• water.</li> </ul>
<p>Examine the pattern of light made by a laser passing through two slits.</p> <p>Use OHP wave plates to show interference patterns.</p> <p>Use Polaroid lenses or filters to block out rays of light.</p> <p>Use Polaroid lenses or filters to show that light reflected off water is polarised.</p>	<p>Recall that light travels in straight lines, to include recall of evidence to support this theory (e.g. shadows and eclipses).</p> <p>Recognise that under certain circumstances light can ‘bend’.</p> <p>Recall that all electromagnetic waves are transverse.</p>
<p>Compare the conflicting light theories of Huygens (waves) and Newton (particles) and how acceptance of the theories changed over time.</p>	<p>Recall that explanations of the nature of light have changed over time, with some scientists describing light as waves, and some scientists describing light as particles.</p> <p>Describe reflection of light in terms of a particle model.</p>

### Module P5: Space For Reflection

#### Item P5f: Nature of waves

**Links to other items:** P1c: A spectrum of waves, P1e: Cooking and communicating using waves, P1g: Wireless signals, P5g: Refraction of waves

<b>Assessable learning outcomes both tiers: standard demand</b>	<b>Assessable learning outcomes Higher Tier only: high demand</b>
<p>Describe the interference of two waves in terms of reinforcement and cancellation of the waves.</p> <p>Apply understanding of interference to describe practical examples of interference effects using sound waves, surface water waves or microwaves.</p> <p>Recall that coherent wave sources are needed to produce a stable interference pattern.</p> <p>Recall that for light the coherent sources are monochromatic light.</p>	<p>Explain interference patterns in terms of constructive and destructive interference.</p> <p>Explain how the number of half wavelengths in the path difference for two waves from the same source relates to the type of interference used.</p> <p>Describe the properties of coherent wave sources:</p> <ul style="list-style-type: none"> <li>• same frequency</li> <li>• in phase</li> <li>• same amplitude.</li> </ul>
<p>Describe diffraction of light for:</p> <ul style="list-style-type: none"> <li>• a single slit</li> <li>• double slits</li> </ul> <p>and that the interference patterns produced are evidence for the wave nature of light.</p> <p>Explain what is meant by plane polarised light.</p> <p>Understand that all electromagnetic waves are transverse waves and so can be plane polarised.</p>	<p>Explain a diffraction pattern for light to include:</p> <ul style="list-style-type: none"> <li>• the size of the gap must be of the order of the wavelength of light</li> <li>• how the diffracted waves interfere to produce the pattern.</li> </ul> <p>Explain how polarisation is used in the application of Polaroid filters and sunglasses including:</p> <ul style="list-style-type: none"> <li>• light from some substances (e.g. water) is partly plane polarised</li> <li>• what the Polaroid filter does to this plane polarised light.</li> </ul>
<p>Explain why the particle theory of light is not universally accepted.</p>	<p>Explain how the wave theory of light has supplanted the particle theory, as the evidence base has changed over time.</p>

### Module P5: Space For Reflection

#### Item P5g: Refraction of waves

**Summary:** Drive along a road on a hot day and you may see water appear to be on the surface of the road. Even more strangely, however, is that this puddle is not actually there when you get there. Such optical illusions are common place and involve the passage of light as it enters and leaves different mediums. This item illustrates how phenomena can be explained by using scientific theories, models and ideas.

Suggested practical and research activities to select from	Assessable learning outcomes Foundation Tier only: low demand
<p>Carry out an experiment to compare the refractive indices of glass and perspex.</p> <p>Survey effects due to refraction such as mirages and apparent depth.</p>	<p>Describe and recognise that refraction involves a change in direction of a wave due to the wave passing from one medium into another.</p> <p>Explain why a ray of light travelling from air into glass has an angle of incidence usually greater than the angle of refraction.</p>
<p>Carry out experiments:</p> <ul style="list-style-type: none"> <li>• to produce a visible spectrum using a prism</li> <li>• recombine the spectral colours using two prisms</li> <li>• use two prisms and a slit to show that there is no further dispersion of a spectral colour.</li> </ul>	<p>Describe and recognise that dispersion happens when light is refracted.</p> <p>Recall the order of the spectral colours and relate this to the order of the wavelengths.</p>
<p>Look in detail at bicycle reflectors and cat's eyes to show that they are prisms.</p> <p>Use prisms to investigate TIR.</p> <p>Show fibre optic cables in action. Fibre optic Christmas tree lights are a good source of these.</p> <p>Make a wall chart, leaflet or PowerPoint presentation of the many uses of TIR including optical fibres to illustrate the development of useful products from scientific ideas.</p> <p>Carry out an experiment to compare the critical incident angle of glass or perspex.</p>	<p>Describe and recognise that some, or all, of a light ray can be reflected when travelling from glass, or water, to air.</p> <p>Recall the many uses of TIR, including:</p> <ul style="list-style-type: none"> <li>• optical fibres</li> <li>• binoculars</li> <li>• reflectors and cat's eyes on the road and road signs.</li> </ul>

### Module P5: Space For Reflection

#### Item P5g: Refraction of waves

**Links to other items:** P1c: A spectrum of waves, P1e: Cooking and communicating using waves, P1g: Wireless signals, P5f: Nature of waves, P5h: Optics

Assessable learning outcomes both tiers: standard demand	Assessable learning outcomes Higher Tier only: high demand
<p>Explain why refraction occurs at the boundary between two media:</p> <ul style="list-style-type: none"> <li>when the wave speed decreases the wave bends towards the normal</li> <li>when the wave speed increases the wave bends away from the normal.</li> </ul> <p>Describe refractive index as a measure of the amount of bending after a boundary.</p> <p>Use the equation:</p> $\text{refractive index} = \frac{\text{speed of light in vacuum}}{\text{speed of light in medium}}$	<p>Interpret data on refractive indices and speed of light to predict the direction of refraction (Snell's law not required).</p> <p>Use the equation, including a change of subject:</p> $\text{refractive index} = \frac{\text{speed of light in vacuum}}{\text{speed of light in medium}}$ <p>This will require the use of standard form notation and/or a scientific notation calculator.</p>
<p>Recall that the amount of bending increases with greater change of wave speed and refractive index.</p> <p>Explain dispersion in terms of spectral colours having different wave speeds in different media but the same speeds in a vacuum.</p>	<p>Explain dispersion in terms of spectral colours having:</p> <ul style="list-style-type: none"> <li>a different speed in glass</li> <li>different refractive indices</li> <li>blue light having a greater refractive index than red light.</li> </ul>
<p>Describe what happens to light incident on a glass/air surface when the angle of incidence is less than, equal to or above the critical angle.</p> <p>Describe the optical path in devices using TIR, including:</p> <ul style="list-style-type: none"> <li>optical fibres</li> <li>binoculars</li> <li>reflectors and cat's eyes on the road and road signs.</li> </ul> <p>Recognise that different media have different critical angles.</p>	<p>Explain the conditions under which total internal reflection (TIR) can occur.</p> <p>Explain how the refractive index of a medium relates to its critical angle.</p>

### Module P5: Space For Reflection

#### Item P5h: Optics

**Summary:** Projecting an image onto a screen is a large industry and involves big money; especially if it's you they are projecting. The cameras used to film the movies use a complex arrangement of lenses to zoom in and focus on the actors, and the images they form are real but inverted.

On a more modest theme many people would struggle with day-to-day life or be unable to read clearly without spectacles. This item takes a look at the many uses of optical devices.

Suggested practical and research activities to select from	Assessable learning outcomes Foundation Tier only: low demand
<p>Carry out an experiment with a convex lens to focus the image of a distant object on the lab wall, e.g. window of lab or inside of lab window.</p> <p>Observe how the distance between the lens and screen varies with focal length. (Focusing image of a distant object on a screen).</p> <p>Construct a simple telescope with one short focal length lens and one long focal length lens.</p>	<p>Recall and identify the shape of a convex lens.</p> <p>Recall that convex lenses are also called converging lenses.</p> <p>Describe what happens to light incident on a convex lens parallel to the axis.</p> <p>Describe the focal length of a convex lens as being measured from the centre of the lens to focal point (focus).</p> <p>Recognise and recall that 'fat' lenses have short focal lengths and 'thin' lenses have long focal lengths.</p>
<p>Carry out an experiment with convex lenses to see how the image of a light bulb varies with the distance of the bulb from the lens.</p>	<p>Recognise and recall that convex lenses produce real images on a screen.</p>
<p>Use pin hole cameras to explore how the size of the aperture (opening) affects both the sharpness and brightness of the image and how focussing is achieved with a lens.</p> <p>Examine different lenses from old spectacles to see the different shapes and thicknesses.</p> <p>Carry out an experiment with a convex lens to measure magnification.</p> <p>Examine an optical instrument. It may be a telescope, microscope or a camera. Look at the arrangement and number of lenses. Look in particular at their differing size and focal lengths.</p>	<p>Recall that convex lenses are used:</p> <ul style="list-style-type: none"> <li>• in cameras</li> <li>• in projectors</li> <li>• in some spectacles</li> <li>• as a magnifying glass.</li> </ul>

## Module P5: Space For Reflection

### Item P5h: Optics

**Links to other items:** P5g: Refraction of waves

<b>Assessable learning outcomes both tiers: standard demand</b>	<b>Assessable learning outcomes Higher Tier only: high demand</b>
<p>Describe the effect of a convex lens on:</p> <ul style="list-style-type: none"> <li>• a diverging beam of light</li> <li>• a parallel beam of light.</li> </ul> <p>For a convex lens recall and recognise:</p> <ul style="list-style-type: none"> <li>• principal axis</li> <li>• focal length</li> <li>• focal point</li> <li>• optical centre of lens.</li> </ul>	<p>Explain the refraction by a convex lens of:</p> <ul style="list-style-type: none"> <li>• a ray travelling parallel to the principal axis before it is incident on the lens</li> <li>• a ray travelling through the focal point of the lens before it is incident on the lens</li> <li>• a ray incident on the centre of the lens.</li> </ul>
<p>Describe how a convex lens produces a real image on film and screen respectively. (A suitable diagram may be required or given).</p>	<p>Explain how to find the position and size of the real image formed by a convex lens by drawing suitable ray diagrams.</p>
<p>Describe the use of a convex lens:</p> <ul style="list-style-type: none"> <li>• in a camera</li> <li>• in a projector</li> <li>• as a magnifying glass.</li> </ul> <p>Explain how the images produced by cameras and projectors are focussed.</p> <p>Use the equation:</p> $\text{magnification} = \frac{\text{image size}}{\text{object size}}$	<p>Describe the properties of real and virtual images.</p> <p>Use the equation, including a change of subject:</p> $\text{magnification} = \frac{\text{image size}}{\text{object size}}$

### 3.9 Module P6: Electricity For Gadgets

#### Module P6: Electricity For Gadgets

##### Item P6a: Resisting

**Summary:** Most electrical devices have some form of control built into their circuits. These increase or decrease current according to an input. Simple examples are the volume of a personal CD-player or the speed of a food processor. More sophisticated examples include the ability to program devices such as microwave cookers or DVD players. The latter is covered more in the last two items of this module.

Suggested practical and research activities to select from	Assessable learning outcomes Foundation Tier only: low demand
Carry out an experiment using a variable resistor as a dimmer unit to control the brightness of a bulb and measure the current in the circuit.	<p>Recognise and draw the circuit symbols for a resistor, variable resistor (rheostat), bulb, cell, battery, switch and power supply.</p> <p>Describe and recognise that a variable resistor (rheostat) can be used to vary the brightness of a lamp.</p>
Carry out an experiment to investigate the voltage-current characteristics of ohmic conductors.	<p>Recall the units of voltage, current and resistance. Use the equation:</p> $\text{resistance} = \frac{\text{voltage}}{\text{current}}$ <p>Recall and identify that for a given ohmic conductor the current increases as the voltage increases.</p>
Carry out an experiment to investigate the voltage-current characteristics of a non-ohmic device, such as a bulb.	<p>Understand that current in a wire is a flow of charge carriers called electrons.</p> <p>Use models of atomic structure to explain electrical resistance in a metal conductor in terms of charge carriers (electrons) colliding with atoms (ions) in the conductor.</p> <p>Recall and identify how the resistance changes as a wire becomes hot.</p>

## Module P6: Electricity For Gadgets

**Item P6a:** Resisting

**Links to other items:** P4c: Safe electricals, P6b: Sharing

Assessable learning outcomes both tiers: standard demand	Assessable learning outcomes Higher Tier only: high demand
<p>Explain the effect of a variable resistor (rheostat) in a circuit in terms of:</p> <ul style="list-style-type: none"> <li>control of the current</li> <li>varying the brightness of a bulb or speed of a motor.</li> </ul>	<p>Explain the effect of changing the length of resistance wire in a variable resistor (rheostat) on the resistance.</p>
<p>Use the equation, including a change of subject:</p> $\text{resistance} = \frac{\text{voltage}}{\text{current}}$ <p>Use a voltage-current graph qualitatively to compare the resistances of ohmic conductors.</p>	<p>Calculate the resistance of an ohmic conductor from a voltage-current graph.</p>
<p>Use kinetic theory to explain that for metallic conductors, the collision of charge carriers with atoms makes the atoms vibrate more. This increased atomic vibration:</p> <ul style="list-style-type: none"> <li>causes an increase in collisions (increased resistance)</li> <li>increases the temperature of the conductor.</li> </ul> <p>Describe and recognise how a voltage-current graph shows the changing resistance of a non-ohmic device, such as a bulb.</p>	<p>Explain the shape of a voltage-current graph for a non-ohmic conductor, such as the filament in a lamp, in terms of increasing resistance and temperature.</p>



## Module P6: Electricity For Gadgets

### Item P6b: Sharing

**Summary:** Electronic circuits rely on supply voltage (pd) being split into two smaller voltages. Sometimes, these output voltages also need to be adjusted to a threshold level to give the required output voltage. This item develops ideas about how both fixed and variable resistors are used, together with LDRs and thermistors, to achieve the desired output voltage.

Suggested practical and research activities to select from	Assessable learning outcomes Foundation Tier only: low demand
<p>Examine a potential divider circuit in an electronic device.</p> <p>Use a rheostat as a potential divider to control the brightness of two bulbs in series.</p>	<p>Recall that a potential divider is used to produce a required voltage in a circuit.</p> <p>Understand that two or more resistors in series increase the resistance of the circuit.</p> <p>Calculate the total resistance for resistors in series</p> $\text{e.g. } R_T = R_1 + R_2 + R_3$
<p>Use multimeters to show how the resistance of LDRs and thermistors are affected by external conditions.</p> <p>Examine circuits which use LDRs to control output e.g. lights which come on at night.</p> <p>Examine circuits which use thermistors to control output.</p> <p>Investigate how the fixed resistor in a potential divider can affect the output voltage in temperature sensors and light sensors.</p>	<p>Recognise and draw the symbol for a light dependant resistor (LDR) and a thermistor.</p> <p>Recall and identify that an LDR responds to a change in light level.</p> <p>Recall and identify that a thermistor responds to changes in temperature.</p>
<p>Use multimeters to measure the resistance of resistors individually, in series and in parallel.</p>	

## Module P6: Electricity For Gadgets

### Item P6b: Sharing

Links to other items: P6a: Resisting

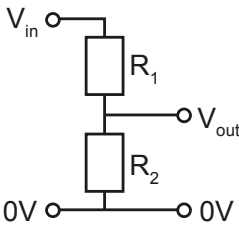
Assessable learning outcomes both tiers: standard demand	Assessable learning outcomes Higher Tier only: high demand
<p>Explain how two fixed resistors can be used as a potential divider.</p> <p>Understand that the output voltage depends on the relative values of the resistors <math>R_1</math> and <math>R_2</math></p> <p>Explain how one fixed resistor and one variable resistor in a potential divider allows variation of the output voltage.</p>	<p>Calculate the value of <math>V_{out}</math> when <math>R_1</math> and <math>R_2</math> are in a simple ratio.</p>  <p>Understand that when <math>R_2</math> is very much greater than <math>R_1</math>, the value of <math>V_{out}</math> is approximately <math>V_{in}</math>.</p> <p>Understand that when <math>R_2</math> is very much less than <math>R_1</math>, the value of <math>V_{out}</math> is approximately zero.</p> <p>Explain how two variable resistors can be used in place of the two fixed resistors to provide an output voltage with an adjustable threshold.</p>
<p>Describe how the resistance of an LDR varies with light level.</p> <p>Describe how the resistance of a thermistor (ntc only) varies with temperature.</p>	<p>Explain why an LDR or a thermistor can be used in place of <math>R_2</math> in a potential divider with a fixed resistor to provide an output signal which depends on light or temperature conditions.</p>
<p>Understand that placing resistors in parallel rather than in series will reduce the total resistance of the circuit.</p>	<p>Calculate the total resistance for resistors in parallel</p> $\text{e.g. } \frac{1}{R_T} = \frac{1}{R_1} + \frac{1}{R_2} + \frac{1}{R_3}$

### Module P6: Electricity For Gadgets

#### Item P6c: It's logical

**Summary:** Many electronic devices rely on some form of logic circuit. The personal computer is probably the best known example, but washing machines and car ignitions also contain the silicon chip. This item develops ideas about logic circuits and the gates which are used.

Suggested practical and research activities to select from	Assessable learning outcomes Foundation Tier only: low demand
<p>Examine a simple NPN transistor circuit used as a switch.</p> <p>View a microprocessor chip with casing removed using a microscope.</p>	<p>Recall that the transistor is the basic building block of electronic components and that the average computer may have millions/billions of them within its circuits.</p> <p>Recall that the transistor is an electronic switch.</p> <p>Recognise and draw the symbol for an NPN transistor and label its terminals.</p>
<p>Examine a combination of transistors used as an AND gate.</p>	<p>Recall that transistors can be connected together to make logic gates.</p> <p>Recall that the input signal for a logic gate is either a high voltage (about 5V) or a low voltage (about 0V).</p>
<p>Show that setting conditions, such as either driver's door OR passenger's door OR both doors need to be open before the courtesy light in a car switches on, leads to a truth table.</p> <p>Carry out experiments to show the actions of NOT, AND and OR (higher tier NAND and NOR) logic gates.</p> <p>Build logic gate circuits to solve problems.</p>	<p>Describe the truth table for a NOT logic gate in terms of high and low signals.</p>

## Module P6: Electricity For Gadgets

### Item P6c: It's logical

**Links to other items:** P6d: Even more logical

#### Assessable learning outcomes both tiers: standard demand

Describe the benefits and drawbacks of increasing miniaturisation of electronic components to manufacturers and to users of the products.

Understand how a small base current ( $I_b$ ) is needed to switch a greater current flowing through the collector ( $I_c$ ) and emitter ( $I_e$ ).

Use the equation:

$$I_e = I_b + I_c$$

#### Assessable learning outcomes Higher Tier only: high demand

Explain how increasing availability of computer power requires society to make choices about acceptable uses of new technologies.

Complete a labelled circuit diagram to show how an NPN transistor can be used as a switch for a light-emitting diode (LED).

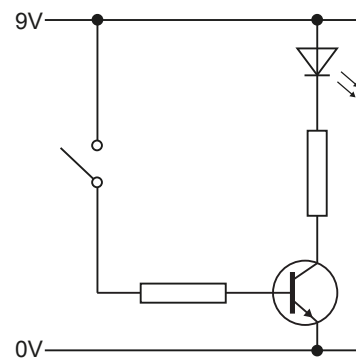

Explain why a high resistor is placed in the base circuit.

Recognise the circuit diagram for an AND gate as two transistors connected together.

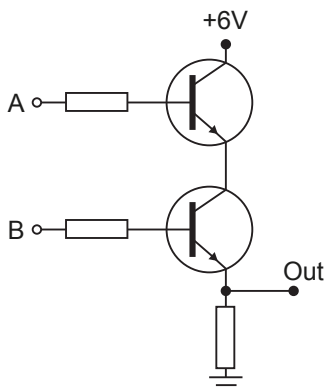

Recall that other logic gates can be made from a combination of two transistors.

Complete a labelled diagram to show how two transistors are connected to make an AND gate.

Describe the truth tables for AND and OR logic gates in terms of high and low signals.

Describe the truth table for NAND and NOR logic gates in terms of high and low signals.

### Module P6: Electricity For Gadgets

**Item P6d:** Even more logical

**Summary:** In practice, most electronic devices require many logic gates combined to give the necessary output under a variety of conditions. This item develops ideas about how truth tables are used to show how logic gates can be combined.

<b>Suggested practical and research activities to select from</b>	<b>Assessable learning outcomes Foundation Tier only: low demand</b>
Examine common devices which use more than one logic gate.	Recall and identify the input and output signals in an electronic system with a combination of logic gates.
Carry out investigations to solve problems using two or more logic gates combined together.  Investigate the operation of a relay.	Recognise that the output current from a logic gate is able to light an LED.  Recognise and draw the symbols for an LED and a relay.  Recall that a relay can be used as a switch.

### Module P6: Electricity For Gadgets

**Item P6d:** Even more logical

**Links to other items:** P6c: It's logical

<b>Assessable learning outcomes both tiers: standard demand</b>	<b>Assessable learning outcomes Higher Tier only: high demand</b>
Complete a truth table of a logic system with up to three inputs made from logic gates.	Complete a truth table of a logic system with up to four inputs made from logic gates.
Describe how to use switches, LDRs and thermistors in series with fixed resistors to provide input signals for logic gates.	Explain how a thermistor or an LDR can be used with a fixed resistor to generate a signal for a logic gate which depends on temperature or light conditions.  Explain how a thermistor or an LDR can be used with a variable resistor to provide a signal with an adjustable threshold voltage for a logic gate.
Explain how an LED and series resistor can be used to indicate the output of a logic gate.  Describe how a relay uses a small current in the relay coil to switch on a circuit in which a larger current flows.	Explain why a relay is needed for a logic gate to switch a current in a mains circuit: <ul style="list-style-type: none"> <li>• a logic gate is a low power device that would be damaged if exposed directly to mains power</li> <li>• the relay isolates the low voltage in the sensing circuit from the high voltage mains.</li> </ul>

### Module P6: Electricity For Gadgets

#### Item P6e: Motoring

**Summary:** Many of the electrical devices we use every day contain electric motors. They can be very small such as in a CD player or much larger in devices such as washing machines. This item develops ideas about the magnetic effect of an electric current and how magnetic fields interact to produce the movement needed for a motor.

Suggested practical and research activities to select from	Assessable learning outcomes Foundation Tier only: low demand
<p>Examine the magnetic field around a current-carrying wire and a coil.</p> <p>Show that a current-carrying wire placed in a magnetic field has a force acting on it.</p>	<p>Recall that a current-carrying wire has a circular magnetic field around it.</p> <p>Describe and recognise that this field is made up of concentric circles.</p> <p>Explain why a current-carrying straight wire placed in a magnetic field can move.</p>
<p>Examine the construction of both simple and practical motors.</p> <p>Research electric motors.</p> <p>Build a DC motor.</p>	<p>Recall that motors are found in a variety of everyday applications e.g. washing machine, CD player, food processor, electric drill, fan, windscreen wiper.</p> <p>Recall that electric motors transfer energy to the load (as useful work) and to the surroundings (as waste heat).</p>

## Module P6: Electricity For Gadgets

### Item P6e: Motoring

**Links to other items:** P6f: Generating

<b>Assessable learning outcomes both tiers: standard demand</b>	<b>Assessable learning outcomes Higher Tier only: high demand</b>
<p>Describe the shape of the magnetic field around a straight wire, a rectangular coil and a solenoid.</p> <p>Understand that a current-carrying wire at right angles to a magnetic field experiences a force.</p> <p>Describe the effect of reversing the current and/or the direction of the magnetic field.</p>	<p>Explain how Fleming's Left Hand Rule is used to predict the direction of the force on a current-carrying wire.</p>
<p>Explain how the forces on a current-carrying coil in a magnetic field produce a turning effect on the coil.</p> <p>Explain how this effect is used in a simple DC electric motor.</p> <p>Describe the effect of changing:</p> <ul style="list-style-type: none"> <li>• the size of the electric current</li> <li>• the number of turns on the coil</li> <li>• the strength of the magnetic field.</li> </ul>	<p>Explain how the direction of the force on the coil in a DC electric motor is maintained in terms of the change of current direction every half-turn.</p> <p>Describe how this is achieved using a split-ring commutator in a simple DC electric motor.</p> <p>Explain why practical motors have a radial field produced by curved pole pieces.</p>



### Module P6: Electricity For Gadgets

#### Item P6f: Generating

**Summary:** Electricity is a very convenient energy source which allows us to use the everyday appliances at home, school and work. As well as being convenient it is readily available, easy to use, versatile and clean at the point of use. This item develops ideas about how electricity is generated.

Suggested practical and research activities to select from	Assessable learning outcomes Foundation Tier only: low demand
<p>Demonstrate the induction effect using a strong magnet and a wire.</p> <p>Using a coil and a strong magnet, show the effect of increasing the number of turns and changing the relative motion of the magnet and coil.</p> <p>Build a model generator.</p> <p>Examine and research the differences between a model generator and a generator in a power station.</p>	<p>Describe and recognise the dynamo effect: electricity can be generated by:</p> <ul style="list-style-type: none"> <li>• moving a wire near a magnet</li> <li>• moving a magnet near a wire.</li> </ul> <p>Label a diagram of an AC generator to show the coil, magnets, slip rings and brushes.</p>
<p>Examine ways in which the electrical output from a generator can be increased.</p> <p>Compare the voltage output of AC and DC generators using a cathode-ray oscilloscope (CRO) and investigate how rotation speed affects the output.</p>	<p>Describe a generator as a motor working in reverse.</p> <p>Explain why electricity is useful:</p> <ul style="list-style-type: none"> <li>• enables energy to be easily transmitted over long distances</li> <li>• enables energy to be stored for future use.</li> </ul> <p>Recall that in the UK, mains electricity is supplied at 50 Hz.</p>

## Module P6: Electricity For Gadgets

**Item P6f:** Generating

**Links to other items:** P2b: Generating electricity, P6e: Motoring

<b>Assessable learning outcomes both tiers: standard demand</b>	<b>Assessable learning outcomes Higher Tier only: high demand</b>
<p>Understand that a voltage is induced across a wire when the wire moves relative to a magnetic field.</p> <p>Understand that a voltage is induced across a coil when the magnetic field within it changes.</p> <p>Describe the effect of reversing the direction of the changing magnetic field.</p>	<p>Explain how the size of the induced voltage depends on the rate at which the magnetic field changes.</p>
<p>Explain why the rotation of a magnet inside a coil of wire induces an alternating current.</p> <p>Recall that electricity is generated in a power station when an electromagnet rotates inside coils of wire.</p> <p>Describe how changing the speed of rotation of the electromagnet's coil(s) affects the size and frequency of the voltage generated.</p> <p>Describe how changing the number of turns on the electromagnet's coil(s) affects the size of the voltage generated.</p>	<p>When provided with a diagram, explain how an AC generator works including the action of the slip rings and brushes.</p>

## Module P6: Electricity For Gadgets

### Item P6g: Transforming

**Summary:** There are many electrical and electronic devices which work on voltages much lower than mains voltage. Electricity is transmitted around the country at voltages very much higher than mains voltage. This means that the current is lower, therefore, less energy is wasted heating up the power lines. This item develops ideas about transformers as devices which change voltage or isolate a supply. The research on the different voltages in the National Grid allow the use of ICT as a teaching and learning resource.

Suggested practical and research activities to select from	Assessable learning outcomes Foundation Tier only: low demand
<p>Examine household devices that contain transformers.</p> <p>Demonstrate step-up and step-down transformers.</p>	<p>Recall that transformers are devices that:</p> <ul style="list-style-type: none"> <li>• work with AC and do not work with DC</li> <li>• do not change AC into DC.</li> </ul> <p>Understand and use the terms step-up transformer and step-down transformer.</p> <p>Recall that step-down transformers are used in a variety of everyday applications e.g. phone chargers, radios, laptops.</p>
	<p>Recognise and draw the symbol for a transformer.</p> <p>Recall that an isolating transformer is used in a bathroom shaver socket.</p>
<p>Research how different voltages are used in the National Grid.</p> <p>Research how real transformers in the National Grid work.</p> <p>Demonstrate model power lines to show power losses.</p>	<p>Recall that step-up transformers are used to increase the voltage from the generator at a power station to supply the National Grid.</p> <p>Recall that step-down transformers are used in sub-stations to reduce the voltage for domestic and commercial use.</p>

## Module P6: Electricity For Gadgets

### Item P6g: Transforming

**Links to other items:** P2b: Generating electricity

<b>Assessable learning outcomes both tiers: standard demand</b>	<b>Assessable learning outcomes Higher Tier only: high demand</b>
<p>Describe the construction of a transformer as two coils of wire wound on an iron core.</p> <p>Describe the difference in construction of a step-up and a step-down transformer and how this construction changes the size of the output.</p>	<p>Explain why the use of transformers requires the use of alternating current.</p> <p>Describe how the changing field in the primary coil of a transformer induces an output voltage in the secondary coil.</p> <p>Use and manipulate the equation:</p> $\frac{\text{voltage across primary coil}}{\text{voltage across secondary coil}} = \frac{\text{no.primary turns}}{\text{no.secondary turns}}$
<p>Explain why an isolating transformer is used in some mains circuits (e.g. bathroom shaver socket).</p>	<p>Explain why isolating transformers:</p> <ul style="list-style-type: none"> <li>• have equal numbers of turns in the primary and secondary coils</li> <li>• improve safety in some mains circuits.</li> </ul>
<p>Recall and identify that some power is lost through heat in the transmission of electrical power in cables and transformers.</p>	<p>Understand how power loss in the transmission of electrical power is related to the current flowing in the transmission lines.</p> <p>Use the equation:</p> $\text{power loss} = \text{current}^2 \times \text{resistance}$ <p>Use and manipulate the equation:</p> $V_p I_p = V_s I_s$ <p>applied to a (100% efficient) transformer.</p> <p>Use these relationships to explain why power is transmitted at high voltages.</p>

### Module P6: Electricity For Gadgets

#### Item P6h: Charging

**Summary:** As well as changing the voltage, using a transformer, it is often necessary to change the current from AC to DC. This item develops ideas about the use of diodes and capacitors to obtain a constant DC output. This is because many things, such as micro chips need a DC supply to work. This item provides the opportunity to discuss contemporary scientific and technological developments.

<b>Suggested practical and research activities to select from</b>	<b>Assessable learning outcomes Foundation Tier only: low demand</b>
Examine the current-voltage characteristics of a diode.	Recognise and draw the symbol for a diode. Recall that a diode only allows a current to pass in one direction.  Understand the direction of current flow from the diode symbol.  Recognise half-wave rectification from a voltage-time graph.
Carry out an experiment to show the difference between half-wave and full-wave rectification.	Recognise full-wave rectification from a voltage-time graph.
Show that a capacitor can store charge.  Show students mains voltage-time history from an uninterruptable power supply.	Recognise and draw the symbol for a capacitor.  Describe the function of a capacitor.  Recall and identify that a capacitor will produce a more constant (smoothed) output.  Explain why many devices need a more constant voltage supply.

### Module P6: Electricity For Gadgets

#### Item P6h: Charging

**Links to other items:** P2b: Generating electricity

<b>Assessable learning outcomes both tiers: standard demand</b>	<b>Assessable learning outcomes Higher Tier only: high demand</b>
<p>Recognise the current-voltage characteristics for a silicon diode.</p> <p>Use this graph to explain that a diode only allows current to flow in one direction.</p> <p>Recall and identify that a single diode produces half-wave rectification.</p>	<p>Explain the current-voltage graph for a silicon diode in terms of high resistance in reverse direction and low resistance in forward directions.</p> <p>Describe the action of a silicon diode in terms of the movement of holes and electrons.</p>
<p>Recall that four diodes can be used in the construction of a bridge circuit to obtain full-wave rectification.</p>	<p>Explain how four diodes in a bridge circuit can produce full-wave rectification.</p>
<p>Describe the result of a current flowing in a circuit containing an uncharged capacitor:</p> <ul style="list-style-type: none"> <li>• charge is stored</li> <li>• the voltage across the capacitor increases.</li> </ul> <p>Understand how the flow of current changes with time when a conductor is connected across a charged capacitor.</p>	<p>Describe the flow of current and reduction in voltage across a capacitor when a conductor is connected across it.</p> <p>Explain the action of a capacitor in a simple smoothing circuit.</p>

## 4.1 Overview of the assessment in GCSE Physics B

To claim the qualification GCSE Physics B (J265) candidates will need to complete all three units.

## GCSE Physics B J265

Unit B751: *Physics modules P1, P2, P3*

35% of the total GCSE

1 hour 15 mins written paper

75 marks

This question paper:

- is offered in Foundation and Higher Tiers
- focuses on modules P1, P2 and P3
- uses structured questions (candidates answer all questions)
- assesses the quality of written communication.

Unit B752: *Physics modules P4, P5, P6*

40% of the total GCSE

1 hour 30 mins written paper

85 marks

This question paper:

- is offered in Foundation and Higher Tiers
- focuses on modules P4, P5 and P6
- includes a 10 mark data response section which assesses AO3 (analyse and evaluate evidence, make reasoned judgements and draw conclusions based on evidence)
- uses structured questions (candidates answer all questions)
- assesses the quality of written communication.

Unit B753: *Physics controlled assessment*

25% of the total GCSE

Controlled assessment

Approximately 7 hours

48 marks

This unit:

- comprises one assessment task, split into three parts
- is assessed by teachers, internally standardised and then externally moderated by OCR
- assesses the quality of written communication.

## 4.2 Tiers

All written papers are set in one of two tiers: Foundation Tier and Higher Tier. Foundation Tier papers assess grades G to C and Higher Tier papers assess grades D to A\*. An allowed grade E may be awarded on the Higher Tier components.

In Units B751 and B752, candidates are entered for an option in either the Foundation Tier or the Higher Tier. Unit B753 (controlled assessment) is not tiered.

Candidates may enter for either the Foundation Tier or Higher Tier in each of the externally assessed units. So, a candidate may take, for example B751/F and B752/H.

## 4.3 Assessment Objectives (AOs)

Candidates are expected to demonstrate their ability to:

AO1	recall, select and communicate their knowledge and understanding of physics
AO2	apply skills, knowledge and understanding of physics in practical and other contexts
AO3	analyse and evaluate evidence, make reasoned judgements and draw conclusions based on evidence.

### 4.3.1 AO weightings – GCSE Physics B

The relationship between the units and the assessment objectives of the scheme of assessment is shown in the following grid:

Unit	% of GCSE			
	AO1	AO2	AO3	Total
Unit B751: <i>Physics modules P1, P2, P3</i>	16	17.5	1.5	35
Unit B752: <i>Physics modules P4, P5, P6</i>	16	17.5	6.5	40
Unit B753: <i>Physics controlled assessment</i>	2	5	18	25
Total	34	40	26	100



#### 4.4 Grading and awarding grades

GCSE results are awarded on the scale A\* to G. Units are awarded a\* to g. Grades are indicated on certificates. However, results for candidates who fail to achieve the minimum grade (G or g) will be recorded as *unclassified* (U or u) and this is **not** certificated.

Most GCSEs are unitised schemes. When working out candidates' overall grades OCR needs to be able to compare performance on the same unit in different series when different grade boundaries may have been set, and between different units. OCR uses a Uniform Mark Scale to enable this to be done.

A candidate's uniform mark for each unit is calculated from the candidate's raw mark on that unit. The raw mark boundary marks are converted to the equivalent uniform mark boundary. Marks between grade boundaries are converted on a pro rata basis.

When unit results are issued, the candidate's unit grade and uniform mark are given. The uniform mark is shown out of the maximum uniform mark for the unit, e.g. 60/100.

The specification is graded on a Uniform Mark Scale. The uniform mark thresholds for each of the assessments are shown below:

(GCSE) Unit Weighting	Maximum Unit Uniform Mark	Unit Grade								
		a*	a	b	c	d	e	f	g	u
25%	100	90	80	70	60	50	40	30	20	0
35% F	97	–	–	–	84	70	56	42	28	0
35% H	140	126	112	98	84	70	63	–	–	0
40% F	111	–	–	–	96	80	64	48	32	0
40% H	160	144	128	112	96	80	72	–	–	

Higher Tier candidates who fail to gain a 'd' grade may achieve an "allowed e". Higher Tier candidates who miss the allowed grade 'e' will be graded as 'u'.

A candidate's uniform marks for each unit are aggregated and grades for the specification are generated on the following scale:

Qualification	Max Uniform Mark	Qualification Grade								
		A*	A	B	C	D	E	F	G	U
GCSE	400	360	320	280	240	200	160	120	80	0

The written papers will have a total weighting of 75% and controlled assessment a weighting of 25%.

A candidate's uniform mark for each paper will be combined with the uniform mark for the controlled assessment to give a total uniform mark for the specification. The candidate's grade will be determined by the total uniform mark.

## 4.5 Grade descriptions

Grade descriptions are provided to give a general indication of the standards of achievement likely to have been shown by candidates awarded particular grades. The descriptions must be interpreted in relation to the content in the specification; they are not designed to define that content. The grade awarded will depend in practice upon the extent to which the candidate has met the assessment objectives overall. Shortcomings in some aspects of the assessment may be balanced by better performance in others.

The grade descriptors have been produced by the regulatory authorities in collaboration with the awarding bodies.

### 4.5.1 Grade F

Candidates recall, select and communicate limited knowledge and understanding of physics. They show a limited understanding that scientific advances may have ethical implications, benefits and risks. They recognise simple inter-relationships between physics and society. They use limited scientific and technical knowledge, terminology and conventions, showing some understanding of scale in terms of time, size and space.

They apply skills, including limited communication, mathematical, technical and observational skills, knowledge and understanding in practical and some other contexts. They recognise and use hypotheses, evidence and explanations and can explain straightforward models of phenomena, events and processes. Using a limited range of skills and techniques, they answer scientific questions, solve straightforward problems and test ideas.

Candidates interpret and evaluate limited quantitative and qualitative data and information from a narrow range of sources. They can draw elementary conclusions having collected limited evidence.

### 4.5.2 Grade C

Candidates recall, select and communicate secure knowledge and understanding of physics. They demonstrate understanding of the nature of physics, its laws, principles and applications and the relationship between physics and society. They understand that scientific advances may have ethical implications, benefits and risks. They use scientific and technical knowledge, terminology and conventions appropriately, showing understanding of scale in terms of time, size and space.

They apply appropriate skills, including communication, mathematical, technical and observational skills, knowledge and understanding in a range of practical and other contexts. They show understanding of the relationships between hypotheses, evidence, theories and explanations and use models, including mathematical models, to describe abstract ideas, phenomena, events and processes. They use a range of appropriate methods, sources of information and data, applying their skills to address scientific questions, solve problems and test hypotheses.

Candidates analyse, interpret and evaluate a range of quantitative and qualitative data and information. They understand the limitations of evidence and use evidence and information to develop arguments with supporting explanations. They draw conclusions based on the available evidence.

### 4.5.3 Grade A

Candidates recall, select and communicate precise knowledge and detailed understanding of physics. They demonstrate a comprehensive understanding of the nature of physics, its laws, principles and applications and the relationship between physics and society. They understand the relationships between scientific advances, their ethical implications and the benefits and risks associated with them. They use scientific and technical knowledge, terminology and conventions appropriately and consistently showing a detailed understanding of scale in terms of time, size and space.

They apply appropriate skills, including communication, mathematical, technical and observational skills, knowledge and understanding effectively in a wide range of practical and other contexts. They show a comprehensive understanding of the relationships between hypotheses, evidence, theories and explanations and make effective use of models, including mathematical models, to explain abstract ideas, phenomena, events and processes. They use a wide range of appropriate methods, sources of information and data consistently, applying relevant skills to address scientific questions, solve problems and test hypotheses.

Candidates analyse, interpret and critically evaluate a broad range of quantitative and qualitative data and information. They evaluate information systematically to develop arguments and explanations taking account of the limitations of the available evidence. They make reasoned judgments consistently and draw detailed, evidence-based conclusions.

## 4.6 Quality of written communication

Quality of written communication is assessed in all units and is integrated in the marking criteria.

Candidates are expected to:

- ensure that text is legible and that spelling, punctuation and grammar are accurate so that meaning is clear
- present information in a form that suits its purpose
- use an appropriate style of writing and, where applicable, specialist terminology.

Questions assessing quality of written communication will be indicated by the icon of a pencil (.

This section provides general guidance on controlled assessment: what controlled assessment tasks are, when and how they are available; how to plan and manage controlled assessment and what controls must be applied throughout the process. More specific guidance and support is provided in the [Guide to controlled assessment](#) for GCSE Gateway Physics B, available on the OCR website.

## Teaching and Learning

Controlled assessment is designed to be an integral part of teaching and learning. There are many opportunities in teaching and learning to develop skills and use a variety of appropriate materials and equipment. These opportunities allow students to practise a wide range of tasks, and teachers can discuss and comment on performance as appropriate.

When all necessary teaching and learning has taken place and teachers feel that candidates are ready for assessment, candidates can be given the appropriate controlled assessment task.

### 5.1 Controlled assessment tasks

All controlled assessment tasks are set by OCR, are published on Interchange, and may only be submitted in the June examination series. Each year a choice of two tasks will be valid for submission. The number of tasks attempted by a candidate is at the discretion of the centre, but the results of only one may be submitted.

Each task will be valid for submission in a single examination series only. This will be clearly marked on the front cover of each task. Centres must ensure that candidates undertake a task applicable to the required year of submission by checking carefully the examination dates of the tasks on Interchange. Tasks will not be valid for submission in any examination series other than that indicated.

Each year, two new controlled assessment tasks will be made available on Interchange from 1st June for certification in the following academic year, two years ahead of the examination series for which the tasks are to be submitted. Tasks will be removed upon expiry. Guidance on how to access controlled assessment tasks from Interchange is available on the OCR website: [www.ocr.org.uk](http://www.ocr.org.uk).

The same OCR controlled assessment task must **NOT** be used as practice material and then as the actual live assessment material.

### 5.2 Nature of controlled assessment tasks

#### 5.2.1 Introduction to controlled assessment

Controlled assessment tasks have been designed to be an integral part of the teaching of the course. The practical activities will be based on the specification content. It is expected that candidates will complete the task at the appropriate point in the teaching of the specification content.

Opportunities to develop the practical skills required for this task are highlighted in the content of the specification. It is essential that candidates have some advance practice in these skills so that they can maximise their attainment. Candidates will need to take part in a planned learning programme that covers the underpinning knowledge and skills of the unit prior to undertaking the task.

The controlled assessment unit requires the completion of one assessment task. Each task is divided into three parts which are linked into an overall theme. The three parts should be taken in the order of Part 1, Part 2 and Part 3. Stimulus material will be provided which will introduce candidates to the task and direct the work they produce.

### Part 1 – Research and collecting secondary data

Part 1 requires candidates to plan and carry out research. The Part 1 stimulus material introduces the task and provides guidance for the research. The research may be conducted either in class or as a homework exercise. The information collected is required for Parts 2 and 3.

### Part 2 – Planning and collecting primary data

Part 2 requires candidates to develop a hypothesis in response to the Part 2 stimulus material and to plan and carry out an investigation to collect primary data to test their hypothesis. Collecting the data, as well as an assessed skill, will help candidates in Part 3 of the task by:

- enhancing their awareness of the practical techniques involved
- focusing on the quality of the data collected
- making them aware of the risks and necessary safety precautions.

### Part 3 – Analysis and evaluation

Part 3 requires candidates to process and analyse the results from their research (Part 1) and their primary data (Part 2). They will also be required to evaluate their data and the methods used to collect it, and draw and justify a conclusion. Candidates will be guided by questions in an answer booklet.

#### 5.2.2 Summary of task in Unit B753

Assessment task	Task marks	Weighting
<i>Physics controlled assessment task</i> (Part 1, Part 2 and Part 3)	48	25%

### 5.3 Planning and managing controlled assessment

Controlled assessment tasks are available at an early stage to allow planning time prior to delivery. It is anticipated that candidates will spend a total of about 7 hours in producing the work for this unit. Candidates should be allowed sufficient time to complete the tasks.

While the wording of the stimulus material and questions must remain unchanged, practical aspects of these tasks can be adapted so that they allow the use of resources available to the centre, including the availability of equipment and materials for practical work.

Where controlled assessment tasks are adapted by centres this must be in ways that will not put at risk the opportunity for candidates to meet the marking criteria, including the chance to gain marks at the highest level.

Suggested steps and timings are included below, with guidance on regulatory controls at each step of the process. Teachers must ensure that control requirements indicated below are met throughout the process.

The parts of the task should be taken in the order of Part 1, Part 2 and Part 3. Candidates' work for Parts 1 and 2 should be collected on completion and returned to the candidates for Part 3.

### 5.3.1 Part 1 – Research and collecting secondary data

- Research activities **1.5 – 2 hours**

The teacher should introduce Part 1 of the task, including time allocations, an outline of the task, the methods of work, control requirements and deadlines. The teacher may introduce the stimulus material to be used in Part 1.

In Part 1, the research stage, a limited level of control is required. Candidates can undertake the research part of the process without direct teacher supervision. Candidates should be provided with access to resources and materials which allow them to access the full range of marking criteria. The work of individual candidates may be informed by working with others; however, candidates must produce an individual response for use in the Part 2 and Part 3 supervised sessions. During the research stage candidates can be given support and guidance. They should be provided with the stimulus which provides the topic for the research. Teachers can explain the task, advise on how the task could be approached, and advise on resources.

Research methods can include fieldwork, internet or paper-based research, questionnaires, audio and video files etc. It is essential that any material directly used from a source is appropriately and rigorously referenced. Further advice and guidance regarding the research stage is provided in the *Guide to controlled assessment* for GCSE Gateway Physics B. Research activities can be lesson or homework time.

At the end of Part 1, candidates will have individually written up their research and collected their research data. This should be collected in and retained by the teacher and returned to the candidate when completing Part 2 and Part 3.

### 5.3.2 Part 2 – Planning and collecting primary data

- Planning **1.5 – 2 hours**
- Practical **1 hour**

The teacher should introduce Part 2 of the task, including time allocations, an outline of the task, the methods of work, control requirements and deadlines. The teacher may introduce the stimulus material to be used in Part 2. Candidates also need access to their individual work and research from Part 1.

In Part 2 candidates are required to formulate a hypothesis, plan an investigation, provide a risk assessment of their plan and carry out the experiment they have planned to collect primary data. Candidates may work in groups of no more than three to develop the plan and carry out the investigation. However, candidates' hypothesis, plan and results must be recorded individually in supervised lesson time.

Teachers should supervise the practical work in accordance with normal practice, to ensure safety procedures (see Appendix D for further guidance). Guidance regarding levels of support is provided in the *Guide to controlled assessment* for GCSE Gateway Physics B. This includes guidance on adapting the tasks for the equipment and materials available to the centre. Candidates will need to be provided with materials and equipment to allow them to access the full range of the marking criteria. Further specific guidance will also be provided with each task.

The work of candidates should be collected in and retained by the teacher and returned to the candidate when completing Part 3.

### 5.3.3 Part 3 – Analysis and evaluation

- Analysis and evaluation **1.5 – 2 hours**

The teacher should introduce Part 3 of the task, including time allocations, an outline of the task, the methods of work, control requirements and deadlines. The teacher may introduce the answer booklet to be used in Part 3.

In Part 3 candidates must work independently under supervised conditions as this part is under high control.

The answer booklet for Part 3 requires candidates to process and analyse the secondary data and information they have collected (Part 1) and the results of their investigation (Part 2). Candidates will need access to their individual responses from Part 1 and Part 2. Questions then guide candidates to evaluate their data and the methods used to collect it, and draw and justify a conclusion.

In processing the data candidates will have opportunities to use mathematical and graphical skills. Candidates must not be instructed or advised in these areas during the task.

On completion of the task, the loose leaf pages for Parts 1 and 2 should be collated and attached to each candidate's Part 3 answer booklet.

### 5.3.4 Supervision by the teacher

Candidates must work individually under limited supervision to:

- record their findings from secondary research in Part 1
- record their hypothesis, experimental plan and risk assessment in Part 2
- record their experimental results in Part 2.

Candidates must work independently under supervised conditions to:

- complete the answer booklet in Part 3.

The work submitted for moderation must be produced under controlled conditions, which means under teacher supervision: teachers must be able to authenticate the work and the candidates must acknowledge and reference any sources used. As writing up of each part is carried out over several sessions, work must be collected in between sessions. The Part 2 stimulus material and Part 3 answer booklet must not be taken out of the supervised sessions.

When supervising tasks, teachers are expected to:

- exercise continuing supervision of work in order to monitor progress and to prevent plagiarism
- provide guidance on the use of information from other sources to ensure that confidentiality and intellectual property rights are maintained
- exercise continuing supervision of practical work to ensure essential compliance with Health and Safety requirements
- ensure that the work is completed in accordance with the specification requirements and can be assessed in accordance with the specified marking criteria and procedures.

Teachers must not provide templates, model answers or feedback on drafts. They may give generic, informal feedback while the task is being completed but may not indicate what candidates need to do to improve their work.



### 5.3.5 Presentation of the work

Candidates must observe the following procedures when producing their final piece of work for the controlled assessment tasks:

- responses to Parts 1 and 2 will be on loose leaf paper. Tables and graphs may be produced using appropriate ICT. These should all be attached to the answer booklet for Part 3
- any copied material must be suitably acknowledged
- quotations must be clearly marked and a reference provided wherever possible
- work submitted for moderation must be marked with the:
  - centre number
  - centre name
  - candidate number
  - candidate name
  - unit code and title
  - task title.

Work submitted on paper for moderation must be secured by treasury tags. Work submitted in digital format (CD or online) must be in a suitable file structure as detailed in Appendix A at the end of this specification.

## 5.4 Marking and moderating controlled assessment

All controlled assessment tasks are marked by the centre assessor(s) using OCR marking criteria and guidance.

This corresponds to a medium level of control.

### 5.4.1 Applying the marking criteria

The starting point for marking the tasks is the marking criteria (see Section 5.4.4 *Marking criteria for controlled assessment tasks* below). The criteria identify levels of performance for the skills, knowledge and understanding that the candidate is required to demonstrate. Additional guidance for each task will be provided alongside the generic marking criteria. At INSET training events and in support materials, OCR will provide exemplification through real or simulated candidate work which will help to clarify the level of achievement that assessors should be looking for when awarding marks.



### 5.4.2 Use of 'best fit' approach to the application of the marking criteria

A controlled assessment task should only be marked when all three parts have been completed. The task should be marked by teachers according to the marking criteria using a 'best fit' approach. For each of the skill qualities, teachers should first use their professional judgement to select one of the four band descriptors provided in the marking grid that most closely describes the quality of the work being marked.

Following the selection of the band descriptor, the most appropriate mark within the band descriptor is chosen. Teachers should use the following guidance to select this mark:

- where the candidate's work *convincingly* meets the statement, the higher mark should be awarded (for example the 3-4 marks band is chosen and 4 marks are awarded)
- where the candidate's work *just* meets the statement, the lower mark should be awarded (for example the 3-4 marks band is chosen and 3 marks are awarded).

Marking should be positive, rewarding achievement rather than penalising failure or omissions. The award of marks **must be** directly related to the marking criteria.

Teachers should use the full range of marks available to them and award *full* marks in any band for work which fully meets that descriptor. This is work which is 'the best one could expect from candidates working at that level'.

The final mark for the candidate for the controlled assessment unit is out of a total of 48 and is found by totalling the marks for each skill quality. Only one mark out of a total of 48 will be required for submission for the unit.

There should be clear evidence that work has been attempted and some work produced. If a candidate submits no work for the internally assessed unit, then the candidate should be indicated as being absent from the unit. If a candidate completes any work at all for an internally assessed unit, then the work should be assessed according to the marking criteria and the appropriate mark awarded, which may be zero.

### 5.4.3 Annotation of candidates' work

Each piece of internally assessed work should show how the marks have been awarded in relation to the marking criteria.

The writing of comments on candidates' work provides a means of communication between teachers during the internal standardisation and with the moderator if the work forms part of the moderation sample.

#### 5.4.4 Marking criteria for controlled assessment tasks

##### Assessment objectives (AOs)

Each of the aspects to be assessed addresses one or more of the assessment objectives and these are shown in the marking criteria. The overall balance is shown in the table below:

Assessment objective	Total
AO1: Recall, select and communicate their knowledge and understanding of science	5
AO2: Apply skills, knowledge and understanding of science in practical and other contexts	10
AO3: Analyse and evaluate evidence, make reasoned judgements and draw conclusions based on evidence	33
<b>Total</b>	<b>48</b>

##### Assessment of the quality of written communication

The quality of written communication is assessed in Parts 2 and 3 of this controlled assessment and indicated by a pencil symbol (✎) for the information of candidates.

Skill quality	1 – 2 marks	3 – 4 marks	5 – 6 marks	AO
<b>Researching:</b> collect secondary data including the use of appropriate technology.	Some information collected and used from at least two sources.	Relevant information collected from at least three sources; information presented clearly and all sources identified.	Range of relevant sources identified and judgement used to select those appropriate to the task. Information collated and presented clearly in appropriate formats including a full bibliography.	AO1 – 1 AO2 – 3 AO3 – 2
<b>Planning:</b> develop hypotheses and plan practical ways to test them.	Simple hypothesis or prediction relates to the data or information provided but does not identify a trend or pattern to be investigated. Outline plan includes equipment and techniques to be used. Plan provides a 'fair test'. No evidence of modifications of plan during the data collection phase. Plan shows limited structure with errors in spelling and punctuation.	Hypothesis provides a limited scientific explanation of the data or information provided. Plan gives sufficient detail for experiment to be repeated, including choices of: equipment and techniques; range and number of data points for the independent variable; number of replicates; other variables to be controlled with the aim of collecting quality data. Some consideration given to how errors will be minimised. No evidence of modifications of plan during the data collection phase. Plan structured clearly with occasional errors in spelling and punctuation.	Complex hypothesis provides a complete scientific explanation of the data or information provided and is capable of investigation. Comprehensive plan shows scientific understanding in making appropriate choices of: equipment, including resolution and techniques; range and number of data points for the independent variable; number of replicates; control of all other variables with the aim of collecting quality data. Detailed consideration given to: how errors will be minimised; variables which cannot be controlled. Where appropriate, reasoned modifications made to the plan as evidence is collected. Plan structured coherently with few, if any, errors in grammar, punctuation and spelling.	AO1 – 1 AO2 – 3 AO3 – 2
<b>Collecting data:</b> collect primary data including the use of appropriate technology.	Results recorded clearly but not in an appropriate format.	Results tabulated to include all data expected, though not in the most appropriate format. Headings given but units not always correct.	Results tabulated clearly and logically, including use of correct headings and units; all data expected recorded to appropriate levels of precision.	AO1 – 2 AO2 – 4

0 marks = no response or no response worthy of credit

Skill quality	1 – 2 marks	3 – 4 marks	5 – 6 marks	AO
<p><b>Managing risk:</b> manage risks when carrying out practical work including risk assessment.</p>	<p>Limited understanding of risks in procedures with only standard laboratory safety features mentioned. Some teacher intervention required to ensure safety.</p>	<p>Some risks in procedures analysed and some specific responses suggested to reduce risks. Risks managed successfully with no significant incidents or accidents and no requirement for teacher intervention.</p>	<p>All significant risks in the plan evaluated. Reasoned judgments made to reduce risks by use of appropriate specific responses. Risks managed successfully with no incidents or accidents and no requirement for teacher intervention.</p>	AO3 – 6
<p><b>Processing data:</b> process primary and secondary data including the use of appropriate technology.</p>	<p>Some evidence of processing quantitative data: data presented as simple charts or graphs with some errors in scaling or plotting; use of one simple mathematical technique.</p>	<p>Graphical and mathematical techniques used to reveal patterns in the data: charts or graphs used to display data in an appropriate way, allowing some errors in scaling or plotting; correct use of more than one simple mathematical technique.</p>	<p>Appropriate graphical and mathematical techniques used to reveal patterns in the data: type of graph, scales and axes selected and data plotted accurately, including where appropriate a line of best fit; correct use of complex mathematical techniques where appropriate; appropriate quantitative treatment of level of uncertainty of data.</p>	AO3 – 6
<p><b>Analysing and interpreting:</b> analyse and interpret primary and secondary data.</p>	<p>At least one trend/pattern identified and outlined correctly; an attempt is made to interpret the information linking primary and secondary data/information.</p>	<p>Main trend(s)/pattern(s) described and interpreted with reference to quantitative data and scientific knowledge and understanding, with some errors; reasoned comparison between primary and secondary data/information; any anomalous results identified correctly and implications discussed.</p>	<p>All trend(s)/pattern(s) described and interpreted correctly with reference to quantitative data and relevant scientific knowledge and understanding; links between primary and secondary data/information evaluated; level of uncertainty of the evidence analysed.</p>	AO3 – 6

0 marks = no response or no response worthy of credit

Skill quality	1 – 2 marks	3 – 4 marks	5 – 6 marks	AO
<p><b>Evaluating:</b>  review methodology to assess fitness for purpose.</p>	<p>Relevant comments made about the quality of the data and the method used. Answer is simplistic with limited use of specialist terms.</p>	<p>Comments made on the quality of the data including accuracy and sources of error, linked to the method of collection; limitations in the method of data collection identified and suggestions for improvement given. Information is relevant and presented in a structured format. Specialist terms are for the most part used appropriately.</p>	<p>Detailed and critical consideration given to the data and methods used to obtain them: sources of error and quality of the data discussed and explained, including accuracy, repeatability and uncertainty; limitations of the method identified and suggestions for improvements justified. Information is relevant, clear, organised and presented in a coherent format. Specialist terms are used appropriately.</p>	<p>AO1 – 1 AO3 – 5</p>
<p><b>Justifying a conclusion:</b> draw evidence-based conclusions; review hypotheses in light of outcomes.</p>	<p>Conclusion given and hypothesis reviewed using the data collected. Answers simplistic with little scientific understanding.</p>	<p>Conclusion given and justified and hypothesis reviewed based on an analysis of the data and information from research and investigation, demonstrating an understanding of the underpinning science.</p>	<p>Conclusion given and justified and hypothesis reviewed, based on a critical analysis of the data and information from research and investigation, and clearly linked to relevant scientific knowledge and understanding.</p>	<p>A03 – 6</p>

0 marks = no response or no response worthy of credit

### 5.4.5 Authentication of work

Teachers must be confident that the work they mark is the candidate's own. This does not mean that a candidate must be supervised throughout the completion of all work but the teacher must exercise sufficient supervision, or introduce sufficient checks, to be in a position to judge the authenticity of the candidate's work.

Wherever possible, the teacher should discuss work-in-progress with candidates. This will not only ensure that work is underway in a planned and timely manner but will also provide opportunities for assessors to check authenticity of the work and provide general feedback.

Candidates must not plagiarise. Plagiarism is the submission of another's work as one's own and/or failure to acknowledge the source correctly. Plagiarism is considered to be malpractice and could lead to the candidate being disqualified. Plagiarism sometimes occurs innocently when candidates are unaware of the need to reference or acknowledge their sources. It is therefore important that centres ensure that candidates understand that the work they submit must be their own and that they understand the meaning of plagiarism and what penalties may be applied. Candidates may refer to research, quotations or evidence but they must list their sources. The rewards from acknowledging sources, and the credit they will gain from doing so, should be emphasised to candidates as well as the potential risks of failing to acknowledge such material.

Both candidates and teachers must declare that the work is the candidate's own:

- **each candidate** must sign a declaration before submitting their work to their teacher. A [candidate authentication statement](#) that can be used is available to download from the OCR website. These statements should be retained within the centre until all enquiries about results, malpractice and appeals issues have been resolved. **A mark of zero must be recorded if a candidate cannot confirm the authenticity of their work**
- **teachers** are required to declare that the work submitted for internal assessment is the candidate's own work by sending the moderator a [centre authentication form](#) (CCS160) for each unit at the same time as the marks. If a centre fails to provide evidence of authentication, **we will set the mark for that candidate(s) to Pending (Q) for that component until authentication can be provided.**

### 5.5 Internal standardisation

It is important that all internal assessors of this controlled assessment work to common standards. Centres must ensure that the internal standardisation of marks across assessors and teaching groups takes place using an appropriate procedure.

This can be done in a number of ways. In the first year, reference material and OCR training meetings will provide a basis for centres' own standardisation. In subsequent years, this, or centres' own archive material, may be used. Centres are advised to hold preliminary meetings of staff involved to compare standards through cross-marking a small sample of work. After most marking has been completed, a further meeting at which work is exchanged and discussed will enable final adjustments to be made.

### 5.6 Submitting marks and authentication

All work for controlled assessment is marked by the teacher and internally standardised by the centre. Marks are then submitted to OCR **and** your moderator: refer to the OCR website for submission dates of the marks to OCR.

There should be clear evidence that work has been attempted and some work produced. If a candidate submits no work for an internally assessed component, then the candidate should be indicated as being absent from that component. If a candidate completes any work at all for an internally assessed component, then the work should be assessed according to the internal assessment objectives and marking instructions and the appropriate mark awarded, which may be zero.

The centre authentication form (CCS160) must be sent to the moderator with the marks.

### 5.7 Submitting samples of candidate work

#### 5.7.1 Sample requests

Once you have submitted your marks, your exams officer will receive an email requesting a moderation sample. Samples will include work from across the range of attainment of the candidates' work.

The sample of work which is presented to the moderator for moderation must show how the marks have been awarded in relation to the marking criteria defined in Section 5.4.4.

When making your entries, the entry option specifies how the sample for each unit is to be submitted. For each of these units, all candidate work must be submitted using the **same entry option**. It is not possible for centres to offer both options for a unit within the same series. You can choose different options for different units. Please see the Section 8.2.1 for entry codes.

#### 5.7.2 Submitting moderation samples via post

The sample of candidate work must be posted to the moderator within three days of receiving the request. You should use one of the labels provided to send the candidate work.

We would advise you to keep evidence of work submitted to the moderator, e.g. copies of written work or photographs of practical work. You should also obtain a certificate of posting for all work that is posted to the moderator.



### 5.7.3 Submitting moderation samples via the OCR Repository

The OCR Repository is a secure website for centres to upload candidate work and for assessors to access this work digitally. Centres can use the OCR Repository for uploading marked candidate work for moderation.

Centres can access the OCR Repository via OCR Interchange, find their candidate entries in their area of the Repository, and use the Repository to upload files (singly or in bulk) for access by their moderator.

The OCR Repository allows candidates to send evidence in electronic file types that would normally be difficult to submit through postal moderation; for example multimedia or other interactive unit submissions.

The OCR GCSE Physics B unit B753 can be submitted electronically to the OCR Repository via Interchange: please check Section 8.4 for unit entry codes for the OCR Repository.

There are three ways to load files to the OCR Repository:

1. Centres can load multiple files against multiple candidates by clicking on 'Upload candidate files' in the Candidates tab of the Candidate Overview screen.
2. Centres can load multiple files against a specific candidate by clicking on 'Upload files' in the Candidate Details screen.
3. Centres can load multiple administration files by clicking on 'Upload admin files' in the Administration tab of the Candidate Overview screen.

The OCR Repository is seen as a faster, greener and more convenient means of providing work for assessment. It is part of a wider programme bringing digital technology to the assessment process, the aim of which is to provide simpler and easier administration for centres.

Instructions for how to upload files to OCR using the OCR Repository can be found on OCR Interchange.

### 5.8 External moderation

The purpose of moderation is to ensure that the standard of the award of marks for work is the same for each centre and that each teacher has applied the standards appropriately across the range of candidates within the centre.

At this stage, if necessary, centres may be required to provide an additional sample of candidate work (if marks are found to be in the wrong order) or carry out some re-marking. If you receive such a request, please ensure that you respond as quickly as possible to ensure that your candidates' results are not delayed.



### 6.1 Free resources available from the OCR website

The following materials will be available on the OCR website:

- GCSE Physics B Specification
- [specimen assessment materials and mark schemes](#)
- [Guide to controlled assessment](#)
- [sample controlled assessment materials](#)
- [exemplar candidate work](#)
- [Teachers' Handbook](#)
- [sample schemes of work and lesson plans](#)

#### Essential FREE support services including:

- INSET training – for information visit [www.gcse-science.com](http://www.gcse-science.com)
- Interchange – a completely secure, free website to help centres reduce administrative tasks at exam time <http://www.ocr.org.uk/interchange>
- e-alerts – register now for regular updates at [www.ocr.org.uk/2011signup](http://www.ocr.org.uk/2011signup)
- Active Results – detailed item level analysis of candidate results.

### 6.2 Other resources

OCR offers centres a wealth of high quality published support with a choice of 'Official Publisher Partner' and 'Approved Publication' resources, all endorsed by OCR for use with OCR specifications.

#### 6.2.1 Publisher partners

OCR works in close collaboration with publisher partners to ensure you have access to:

- published support materials available when you need them, tailored to OCR specifications
- high quality resources produced in consultation with OCR subject teams, which are linked to OCR's teacher support materials



Collins is the publisher partner for OCR GCSE Additional Science B.

Collins is working with a team of experienced authors to provide resources which will help you deliver the new OCR GCSE Gateway Science specifications.

With Collins New GCSE Science you can:

### Explain

- be sure you're delivering the new specification with content organised and written to match the specifications
- deliver outstanding lessons every time with differentiated lesson plans that include high quality plenaries to check effectiveness of every lesson and expert guidance on how to make a good lesson outstanding

### Explore

- explore Science as it happens in the real world through interactive videos and animations in Interactive Books and How Science Works integrated throughout the series
- emphasise how science is relevant with engaging facts throughout and activities based on the book *Bad Science*, by Ben Goldacre

### Excel

- help your students excel with plenty of practice questions that provide extra support for the quality of written communication
- raise standards with more questions than ever before designed to stretch and challenge high achievers.

#### 6.2.2 Endorsed publications

OCR endorses a range of publisher materials to provide quality support for centres delivering its qualifications. You can be confident that materials branded with OCR's 'Official Publishing Partner' or 'Approved publication' logos have undergone a thorough quality assurance process to achieve endorsement. All responsibility for the content of the publisher's materials rests with the publisher.



These endorsements do not mean that the materials are the only suitable resources available or necessary to achieve an OCR qualification.

### 6.3 Training

OCR will offer a range of support activities for all practitioners throughout the lifetime of the qualification to ensure they have the relevant knowledge and skills to deliver the qualification.

Please see [Event Booker](#) for further information.

### 6.4 OCR support services

#### 6.4.1 Active Results

Active Results is available to all centres offering OCR's GCSE Physics B specification.

## activeresults

Active Results is a free results analysis service to help teachers review the performance of individual candidates or whole schools.

Data can be analysed using filters on several categories such as gender and other demographic information, as well as providing breakdowns of results by question and topic.

Active Results allows you to look in greater detail at your results:

- richer and more granular data will be made available to centres including question level data available from e-marking
- you can identify the strengths and weaknesses of individual candidates and your centre's cohort as a whole
- our systems have been developed in close consultation with teachers so that the technology delivers what you need.

Further information on Active Results can be found on the [OCR website](#).

#### 6.4.2 OCR Interchange

OCR Interchange has been developed to help you to carry out day-to-day administration functions online, quickly and easily. The site allows you to register and enter candidates online. In addition, you can gain immediate and free access to candidate information at your convenience. Sign up on the [OCR website](#).

## 7.1 Equality Act information relating to GCSE Physics B

GCSEs often require assessment of a broad range of competences. This is because they are general qualifications and, as such, prepare candidates for a wide range of occupations and higher level courses.

The revised GCSE qualification and subject criteria were reviewed by the regulators in order to identify whether any of the competences required by the subject presented a potential barrier to any disabled candidates. If this was the case, the situation was reviewed again to ensure that such competences were included only where essential to the subject. The findings of this process were discussed with disability groups and with disabled people.

Reasonable adjustments are made for disabled candidates in order to enable them to access the assessments and to demonstrate what they know and can do. For this reason, very few candidates will have a complete barrier to the assessment. Information on reasonable adjustments is found in *Access Arrangements, Reasonable Adjustments and Special Consideration* by the Joint Council [www.jcq.org.uk](http://www.jcq.org.uk).

Candidates who are unable to access part of the assessment, even after exploring all possibilities through reasonable adjustments, may still be able to receive an award based on the parts of the assessment they have taken.

The access arrangements permissible for use in this specification are in line with Ofqual's GCSE subject criteria equalities review and are as follows:

	Yes/No	Type of Assessment
Readers	Yes	All assessments
Scribes	Yes	All assessments
Practical assistants	Yes	All controlled assessments. The practical assistant may assist with assessed practical tasks under instruction from the candidate.
Word processors	Yes	All assessments
Transcripts	Yes	All assessments
BSL interpreters	Yes	All assessments
Oral language modifiers	Yes	All assessments
Modified question papers	Yes	All assessments
Extra time	Yes	All assessments

## 7.2 Arrangements for candidates with particular requirements (including Special Consideration)

All candidates with a demonstrable need may be eligible for access arrangements to enable them to show what they know and can do. The criteria for eligibility for access arrangements can be found in the JCQ document *Access Arrangements, Reasonable Adjustments and Special Consideration*.

Candidates who have been fully prepared for the assessment but who have been affected by adverse circumstances beyond their control at the time of the examination may be eligible for special consideration. As above, centres should consult the JCQ document *Access Arrangements, Reasonable Adjustments and Special Consideration*.

## 8 Administration of GCSE Physics B

In December 2011 the GCSE qualification criteria were changed by Ofqual. As a result, all GCSE qualifications have been updated to comply with the new regulations.

The most significant change for all GCSE qualifications is that, from 2014, unitised specifications must require that 100% of the assessment is terminal.

Please note that there are no changes to the terminal rule and re-sit rules for the January 2013 and June 2013 examination series:

- at least 40% of the assessment must be taken in the examination series in which the qualification is certificated
- candidates may re-sit each unit once before certification, i.e. each candidate can have two attempts at a unit before certification.

For full information on the assessment availability and rules that apply in the January 2013 and June 2013 examination series, please refer to the previous version of this specification [GCSE Physics B \(March 2011\)](#) available on the website.

The sections below explain in more detail the rules that apply from the June 2014 examination series onwards.

### 8.1 Availability of assessment from 2014

There is one examination series available each year in June (all units are available each year in June).

GCSE Physics B certification is available in June 2014 and each June thereafter.

	Unit B751	Unit B752	Unit B753	Certification availability
June 2014	✓	✓	✓	✓
June 2015	✓	✓	✓	✓

### 8.2 Certification rules

For GCSE Physics B, from June 2014 onwards, a 100% terminal rule applies. Candidates must enter for all their units in the series in which the qualification is certificated.

### 8.3 Rules for re-taking a qualification

Candidates may enter for the qualification an unlimited number of times.

Where a candidate re-takes a qualification, **all** units must be re-entered and all externally assessed units must be re-taken in the same series as the qualification is re-certificated. The new results for these units will be used to calculate the new qualification grade. Any results previously achieved cannot be re-used.

For the controlled assessment unit, candidates who are re-taking a qualification can choose either to re-take that controlled assessment unit or to carry forward the result for that unit that was used towards the previous certification of the same qualification.

- Where a candidate decides to re-take the controlled assessment, the new result will be the one used to calculate the new qualification grade. Any results previously achieved cannot be re-used.

- Where a candidate decides to carry forward a result for controlled assessment, they must be entered for the controlled assessment unit in the re-take series using the entry code for the carry forward option (see section 8.4).

## 8.4 Making entries

### 8.4.1 Unit entries

Centres must be approved to offer OCR qualifications before they can make any entries, including estimated entries. It is recommended that centres apply to OCR to become an approved centre well in advance of making their first entries. Centres must have made an entry for a unit in order for OCR to supply the appropriate forms and administrative materials.

**It is essential** that correct unit entry codes are used when making unit entries.

For the externally assessed units B751 and B752 candidates must be entered for either component 01 (Foundation Tier) or 02 (Higher Tier) using the appropriate unit entry code from the table below. It is not possible for a candidate to take both components for a particular unit within the same series; however, different units may be taken at different tiers.

For the controlled assessment unit, centres can decide whether they want to submit candidates' work for moderation through the OCR Repository or by post. Candidates submitting controlled assessment must be entered for the appropriate unit entry code from the table below. Candidates who are re-taking the qualification and who want to carry forward the controlled assessment should be entered using the unit entry code for the carry forward option.

Centres should note that controlled assessment tasks can still be completed at a time which is appropriate to the centre/candidate. However, where tasks change from year to year, centres would have to ensure that candidates had completed the correct task(s) for the year of entry.

Unit entry code	Component code	Assessment method	Unit titles
B751F	01	Written Paper	<i>Physics modules P1, P2, P3 (Foundation Tier)</i>
B751H	02	Written Paper	<i>Physics modules P1, P2, P3 (Higher Tier)</i>
B752F	01	Written Paper	<i>Physics modules P4, P5, P6 (Foundation Tier)</i>
B752H	02	Written Paper	<i>Physics modules P4, P5, P6 (Higher Tier)</i>
B753A	01	Moderated via OCR Repository	<i>Physics controlled assessment</i>
B753B	02	Moderated via postal moderation	<i>Physics controlled assessment</i>
B753C	80	Carried forward	<i>Physics controlled assessment</i>

### 8.4.2 Certification entries

Candidates must be entered for qualification certification separately from unit assessment(s). If a certification entry is **not** made, no overall grade can be awarded.

Centres must enter candidates for:

- GCSE Physics B certification code J265.

### 8.5 Enquiries about results

Under certain circumstances, a centre may wish to query the result issued to one or more candidates. Enquiries about results for GCSE units must be made immediately following the series in which the relevant unit was taken and by the relevant enquiries about results deadline for that series.

Please refer to the JCQ *Post-Results Services* booklet and the OCR *Admin Guide: 14–19 Qualifications* for further guidance on enquiries about results and deadlines. Copies of the latest versions of these documents can be obtained from the [OCR website](#).

### 8.6 Prohibited qualifications and classification code

Every specification is assigned a national classification code indicating the subject area to which it belongs. The classification code for this specification is 1210.

Centres should be aware that candidates who enter for more than one GCSE qualification with the same classification code will have only one grade (the highest) counted for the purpose of the School and College Performance Tables.

Centres may wish to advise candidates that, if they take two specifications with the same classification code, colleges are very likely to take the view that they have achieved only one of the two GCSEs. The same view may be taken if candidates take two GCSE specifications that have different classification codes but have significant overlap of content. Candidates who have any doubts about their subject combinations should seek advice, either from their centre or from the institution to which they wish to progress.

### 9.1 Overlap with other qualifications

This specification has been developed alongside GCSE Science B, GCSE Additional Science B, GCSE Biology B, GCSE Chemistry B and GCSE Additional Applied Science.

Modules 1 and 2 of this specification are also included in GCSE Science B. Modules 3 and 4 of this specification are also included in GCSE Additional Science B.

Aspects of the controlled assessment of skills are common across GCSE Additional Science B, GCSE Biology B, GCSE Chemistry B and GCSE Physics B.

### 9.2 Progression from this qualification

GCSE qualifications are general qualifications which enable candidates to progress either directly to employment, or to proceed to further qualifications.

Progression to further study from GCSE will depend upon the number and nature of the grades achieved. Broadly, candidates who are awarded mainly Grades D to G at GCSE could either strengthen their base through further study of qualifications at Level 1 within the National Qualifications Framework or could proceed to Level 2. Candidates who are awarded mainly Grades A\* to C at GCSE would be well prepared for study at Level 3 within the National Qualifications Framework.

### 9.3 Avoidance of bias

OCR has taken great care in preparation of this specification and assessment materials to avoid bias of any kind. Special focus is given to the 9 strands of the Equality Act with the aim of ensuring both direct and indirect discrimination is avoided.

### 9.4 Regulatory Requirements

This specification complies in all respects with the current: *General Conditions of Recognition; GCSE, GCE, Principal Learning and Project Code of Practice; GCSE Controlled Assessment regulations* and the *GCSE subject criteria for Physics*. All documents are available on the [Ofqual website](#).

### 9.5 Language

This specification and associated assessment materials are in English only. Only answers written in English will be assessed.



## 9.6 Spiritual, moral, ethical, social, legislative, economic and cultural issues

This specification offers opportunities which can contribute to an understanding of these issues.

The table below gives some examples which could be used when teaching the course:

Issue	Opportunities for developing an understanding of the issue during the course
<p><b>Moral issues</b> The commitment of scientists to publish their findings and subject their ideas to testing by others.</p>	P1h: Describe how people have been informed of the risk of exposure to ultraviolet radiation, including the use of sun beds, in order to improve public health.
<p><b>Ethical issues</b> The ethical implications of selected scientific issues.</p>	P2d: Explain the problems of dealing with radioactive waste.
<p><b>Economical issues</b> The range of factors which have to be considered when weighing the costs and benefits of scientific activity.</p>	P2c: Describe the advantages and disadvantages of nuclear power.
<p><b>Cultural issues</b> Scientific explanations which give insight into the local and global environment.</p>	P1h: Describe reasons for climate change caused by increased global warming.

## 9.7 Sustainable development, health and safety considerations and European developments, consistent with international agreements

This specification supports these issues, consistent with current EU agreements, as outlined below.

- Sustainable development issues could be supported through questions set on efficient use of energy resources and the effects of human activity on climate, for example.
- Health and safety considerations will be supported through the controlled assessment which will include risk assessment of planned practical work and carrying out practical work safely. Health and safety considerations could be supported through questions set on safe use of waves and radiations, car safety and safe use of electricity, for example.
- European developments could be supported through study of different attitudes to power generation, for example.

## 9.8 Key Skills

This specification provides opportunities for the development of the Key Skills of *Communication, Application of Number, Information and Communication Technology, Working with Others, Improving Own Learning and Performance and Problem Solving* at Levels 1 and/or 2. However, the extent to which this evidence fulfils the Key Skills criteria at these levels will be totally dependent on the style of teaching and learning adopted for each unit.

The following table indicates where opportunities may exist for at least some coverage of the various Key Skills criteria at Levels 1 and/or 2 for each unit.

Unit	C		AoN		ICT		WwO		IOLP		PS	
	1	2	1	2	1	2	1	2	1	2	1	2
B751	✓	✓	✓	✓	✓	✓	✓	✓	✓	✓	✓	✓
B752	✓	✓	✓	✓	✓	✓	✓	✓	✓	✓	✓	✓
B753	✓	✓	✓	✓	✓	✓	✓	✓	✓	✓	✓	✓

### 9.9 ICT

In order to play a full part in modern society, candidates need to be confident and effective users of ICT. This specification provides candidates with a wide range of appropriate opportunities to use ICT in order to further their study of Science.

Opportunities for ICT include:

- using video clips to show/provide the context for topics studied and to illustrate the practical importance of the scientific ideas
- gathering information from the internet and CD-ROMs
- gathering data using sensors linked to data-loggers or directly to computers
- using spreadsheets and other software to process data
- using animations and simulations to visualise scientific ideas
- using modelling software to explore theories
- using software to present ideas and information on paper and on screen.

Particular opportunities for the use of ICT appear in the introductions to each item where appropriate.

### 9.10 Citizenship

From September 2002, the National Curriculum for England at Key Stage 4 includes a mandatory programme of study for Citizenship.

GCSE Science is designed as a science education for future citizens which not only covers aspects of the Citizenship programme of study but also extends beyond that programme by dealing with important aspects of science which all people encounter in their everyday lives.

# Appendix A: Guidance for the production of electronic controlled assessment

A

## Structure for evidence

A controlled assessment portfolio is a collection of folders and files containing the candidate's evidence. Folders should be organised in a structured way so that the evidence can be accessed easily by a teacher or moderator. This structure is commonly known as a folder tree. It would be helpful if the location of particular evidence is made clear by naming each file and folder appropriately and by use of an index called 'Home Page'.

There should be a top level folder detailing the candidate's centre number, candidate number, surname and forename, together with the unit code B753, so that the portfolio is clearly identified as the work of one candidate.

Each candidate produces an assignment for controlled assessment. The evidence should be contained within a separate folder within the portfolio. This folder may contain separate files.

Each candidate's controlled assessment portfolio should be stored in a secure area on the centre's network. Prior to submitting the controlled assessment portfolio to OCR, the centre should add a folder to the folder tree containing controlled assessment and summary forms.

## Data formats for evidence

In order to minimise software and hardware compatibility issues it will be necessary to save candidates' work using an appropriate file format.

Candidates must use formats appropriate to the evidence that they are providing and appropriate to viewing for assessment and moderation. Open file formats or proprietary formats for which a downloadable reader or player is available are acceptable. Where this is not available, the file format is not acceptable.

Electronic controlled assessment is designed to give candidates an opportunity to demonstrate what they know, understand and can do using current technology. Candidates do not gain marks for using more sophisticated formats or for using a range of formats. A candidate who chooses to use only word documents will not be disadvantaged by that choice.

Evidence submitted is likely to be in the form of word processed documents, PowerPoint presentations, digital photos and digital video.

To ensure compatibility, all files submitted must be in the formats listed below. Where new formats become available that might be acceptable, OCR will provide further guidance. OCR advises against changing the file format that the document was originally created in. It is the centre's responsibility to ensure that the electronic portfolios submitted for moderation are accessible to the moderator and fully represent the evidence available for each candidate.

**Movie formats for digital video evidence**

MPEG (\*.mpg)

QuickTime movie (\*.mov)

Macromedia Shockwave (\*.aam)

Macromedia Shockwave (\*.dcr)

Flash (\*.swf)

Windows Media File (\*.wmf)

MPEG Video Layer 4 (\*.mp4)

**Audio or sound formats**

MPEG Audio Layer 3 (\*.mp3)

**Graphics formats including photographic evidence**

JPEG (\*.jpg)

Graphics file (\*.pcx)

MS bitmap (\*.bmp)

GIF images (\*.gif)

**Animation formats**

Macromedia Flash (\*.fla)

**Structured markup formats**

XML (\*.xml)

**Text formats**

Comma Separated Values (.csv)

PDF (.pdf)

Rich text format (.rtf)

Text document (.txt)

**Microsoft Office suite**

PowerPoint (.ppt)

Word (.doc)

Excel (.xls)

Visio (.vsd)

Project (.mpp)

## Appendix B: Mathematics skills for GCSE science qualifications

### B

Candidates are permitted to use calculators in all assessments.

Candidates should be able to:

- understand number size and scale and the quantitative relationship between units
- understand when and how to use estimation
- carry out calculations involving  $+$ ,  $-$ ,  $\times$ ,  $\div$ , either singly or in combination, decimals, fractions, percentages and positive whole number powers
- provide answers to calculations to an appropriate number of significant figures
- understand and use the symbols  $=$ ,  $<$ ,  $>$ ,  $\sim$
- understand and use direct proportion and simple ratios
- calculate arithmetic means
- understand and use common measures and simple compound measures such as speed
- plot and draw graphs (line graphs, bar charts, pie charts, scatter graphs, histograms) selecting appropriate scales for the axes
- substitute numerical values into simple formulae and equations using appropriate units
- translate information between graphical and numeric form
- extract and interpret information from charts, graphs and tables
- understand the idea of probability
- calculate area, perimeters and volumes of simple shapes.

In addition, Higher Tier candidates should be able to:

- interpret, order and calculate with numbers written in standard form
- carry out calculations involving negative powers (only  $-1$  for rate)
- change the subject of an equation
- understand and use inverse proportion
- understand and use percentiles and deciles.

It is expected that candidates will show an understanding of the physical quantities and corresponding SI units listed below and will be able to use them in quantitative work and calculations. Whenever they are required for such questions, units will be provided and, where necessary, explained.

#### Fundamental physical quantities

Physical quantity	Unit(s)
length	metre (m); kilometre (km); centimetre (cm); millimetre (mm)
mass	kilogram (kg); gram (g); milligram (mg)
time	second (s); millisecond (ms)
temperature	degree Celsius ( $^{\circ}\text{C}$ ); kelvin (K)
current	ampere (A); milliampere (mA)
voltage	volt (V); millivolt (mV)

#### Derived quantities and units

Physical quantity	Unit(s)
area	$\text{cm}^2$ ; $\text{m}^2$
volume	$\text{cm}^3$ ; $\text{dm}^3$ ; $\text{m}^3$ ; litre (l); millilitre (ml)
density	$\text{kg}/\text{m}^3$ ; $\text{g}/\text{cm}^3$
force	newton (N)
speed	m/s; km/h
energy	joule (J); kilojoule (kJ); megajoule (MJ)
power	watt (W); kilowatt (kW); megawatt (MW)
frequency	hertz (Hz); kilohertz (kHz)
gravitational field strength	N/kg
radioactivity	becquerel (Bq)
acceleration	$\text{m}/\text{s}^2$ ; $\text{km}/\text{h}^2$
specific heat capacity	$\text{J}/\text{kg}^{\circ}\text{C}$ ; $\text{J}/\text{g}^{\circ}\text{C}$
specific latent heat	J/kg

In UK law, health and safety is the responsibility of the employer. For most establishments entering candidates for GCSE, this is likely to be the local education authority or the governing body. Employees, i.e. teachers and lecturers, have a duty to cooperate with their employer on health and safety matters. Various regulations, but especially the COSHH Regulations 2002 and the Management of Health and Safety at Work Regulations 1999, require that before any activity involving a hazardous procedure or harmful micro-organisms is carried out, or hazardous chemicals are used or made, the employer must provide a risk assessment.

For members, the CLEAPSS® guide, *Managing Risk Assessment in Science\** offers detailed advice. Most education employers have adopted a range of nationally available publications as the basis for their Model Risk Assessments. Those commonly used include:

*Safety in Science Education*, DfEE, 1996, HMSO, ISBN 0 11 270915 X

*Topics in Safety*, 3rd edition, 2001, ASE ISBN 0 86357 316 9

*Safeguards in the School Laboratory*, 11th edition, 2006, ASE ISBN 978 0 86357 408 5

CLEAPSS® *Hazcards*, 2007 edition and later updates\*

CLEAPSS® *Laboratory Handbook\**

*Hazardous Chemicals*, A Manual for Science Education, 1997, SSERC Limited

ISBN 0 9531776 0 2

Where an employer has adopted these or other publications as the basis of their model risk assessments, an individual school or college then has to review them, to see if there is a need to modify or adapt them in some way to suit the particular conditions of the establishment.

Such adaptations might include a reduced scale of working, deciding that the fume cupboard provision was inadequate or the skills of the candidates were insufficient to attempt particular activities safely. The significant findings of such risk assessment should then be recorded, for example on schemes of work, published teachers guides, work sheets, etc. There is no specific legal requirement that detailed risk assessment forms should be completed, although a few employers require this.

Where project work or individual investigations, sometimes linked to work-related activities, are included in specifications this may well lead to the use of novel procedures, chemicals or micro-organisms, which are not covered by the employer's model risk assessments. The employer should have given guidance on how to proceed in such cases. Often, for members, it will involve contacting CLEAPSS® (or, in Scotland, SSERC).

\*These, and other CLEAPSS® publications, are on the CLEAPSS® Science Publications CD-ROM issued annually to members. Note that CLEAPSS® publications are only available to members. For more information about CLEAPSS® go to [www.cleapss.org.uk](http://www.cleapss.org.uk). In Scotland, SSERC [www.sserc.org.uk](http://www.sserc.org.uk) has a similar role to CLEAPSS® and there are some reciprocal arrangements.



Junction of  
Conductors

Ammeter

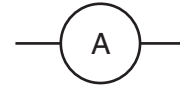

Switch

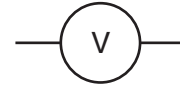
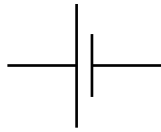

Voltmeter

Primary or  
secondary cellIndicator or light  
source

Battery of cells



or

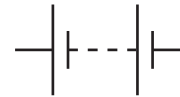

Power supply



Motor

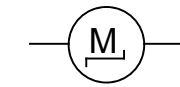

Fuse

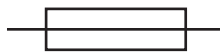

Generator

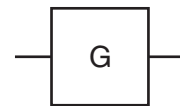

Fixed resistor

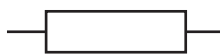

Variable resistor

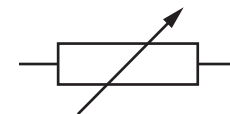

Diode

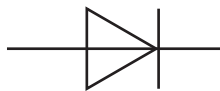

Capacitor



Electrolytic capacitor

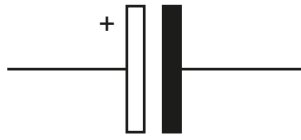

Relay

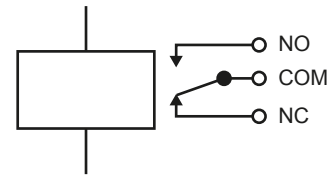

LDR

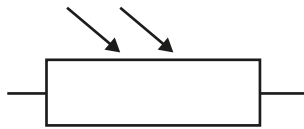

LED

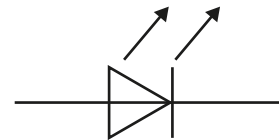

Thermistor

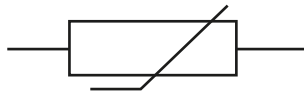

NOT gate

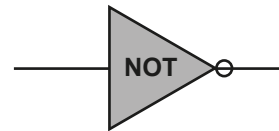

AND gate



OR gate

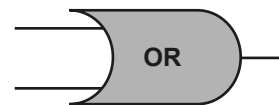

NOR gate



NAND gate



NPN transistor

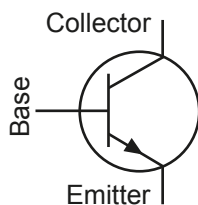



# YOUR CHECKLIST

OUR AIM IS TO PROVIDE YOU WITH ALL THE INFORMATION AND SUPPORT YOU NEED TO DELIVER OUR SPECIFICATIONS.

- Bookmark [www.ocr.org.uk/gcse2012](http://www.ocr.org.uk/gcse2012)
- Be among the first to hear about support materials and resources as they become available. Register for email updates at [www.ocr.org.uk/updates](http://www.ocr.org.uk/updates)
- Find out about our training courses at [www.ocreventbooker.org.uk](http://www.ocreventbooker.org.uk)
- Find out about controlled assessment support at [www.ocr.org.uk/gcse2012](http://www.ocr.org.uk/gcse2012)
- Learn more about Active Results at [www.ocr.org.uk/activeresults](http://www.ocr.org.uk/activeresults)
- Join our social network community for teachers at [www.social.ocr.org.uk](http://www.social.ocr.org.uk)

## NEED MORE HELP?

Here's how to contact us for specialist advice

By phone: 01223 553998

By email: [science@ocr.org.uk](mailto:science@ocr.org.uk)

By online: <http://answers@ocr.org.uk>

By fax: 01223 552627

By post: Customer Contact Centre, OCR,  
Progress House, Westwood Business Park,  
Coventry CV4 8JQ

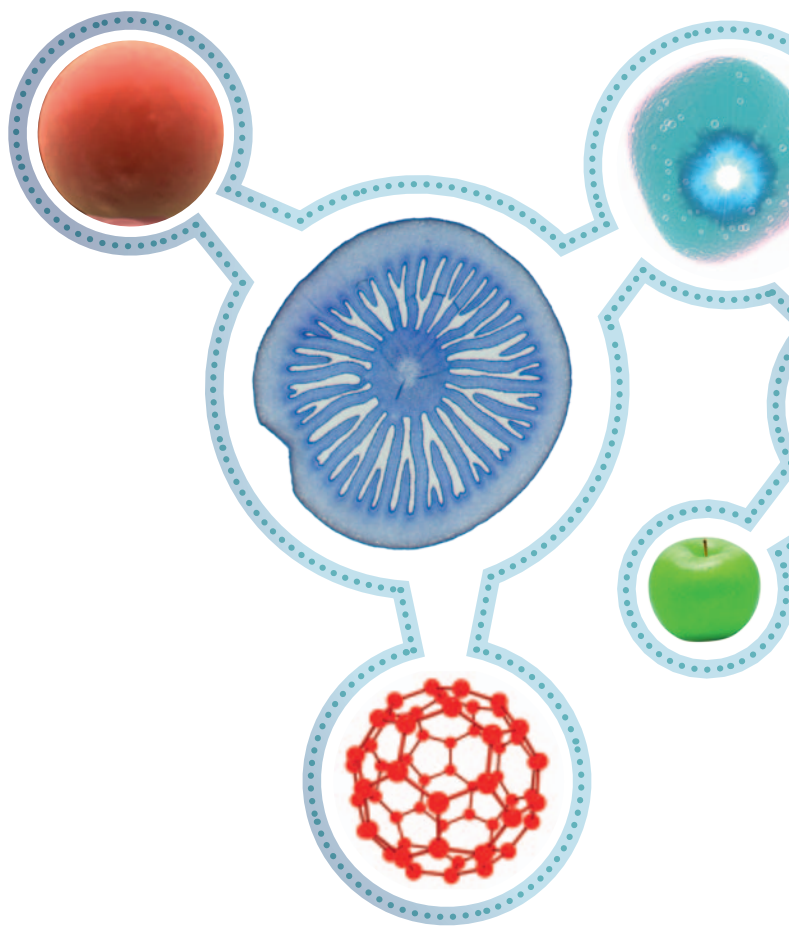

## **GENERAL QUALIFICATIONS**

Telephone 01223 553998

Facsimile 01223 552627

[science@ocr.org.uk](mailto:science@ocr.org.uk)

1 Hills Road, Cambridge CB1 2EU

For staff training purposes and as part of our quality assurance programme your call may be recorded or monitored.

© OCR 2012 Oxford Cambridge and RSA Examinations is a Company Limited by Guarantee. Registered in England.

Registered office 1 Hills Road, Cambridge CB1 2EU.

Registered company number 3484466. OCR is an exempt charity.

**[www.ocr.org.uk/gcse2012](http://www.ocr.org.uk/gcse2012)**

J265/1205/OC607