

**Wednesday 21 June 2017 – Morning**

**GCSE TWENTY FIRST CENTURY SCIENCE  
CHEMISTRY A/FURTHER ADDITIONAL SCIENCE A**

**A173/01** Module C7 (Foundation Tier)

Candidates answer on the Question Paper.  
A calculator may be used for this paper.

**OCR supplied materials:**

None

**Other materials required:**

- Pencil
- Ruler (cm/mm)

**Duration:** 1 hour

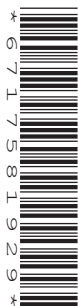

Candidate forename		Candidate surname	
-----------------------	--	----------------------	--

Centre number						Candidate number				
---------------	--	--	--	--	--	------------------	--	--	--	--

### INSTRUCTIONS TO CANDIDATES

- Write your name, centre number and candidate number in the boxes above. Please write clearly and in capital letters.
- Use black ink. HB pencil may be used for graphs and diagrams only.
- Answer **all** the questions.
- Read each question carefully. Make sure you know what you have to do before starting your answer.
- Write your answer to each question in the space provided. If additional space is required, you should use the lined page(s) at the end of this booklet. The question number(s) must be clearly shown.
- Do **not** write in the barcodes.

### INFORMATION FOR CANDIDATES

- The quality of written communication is assessed in questions marked with a pencil (✎).
- The number of marks is given in brackets [ ] at the end of each question or part question.
- The total number of marks for this paper is **60**.
- The Periodic Table is printed on the back page.
- This document consists of **20** pages. Any blank pages are indicated.

Answer **all** the questions.

1 Dee works for a company that uses sodium hydrogencarbonate to make medicines.

(a) Dee uses several stages to make a standard solution of sodium hydrogencarbonate.

Each stage uses different equipment.

Draw straight lines to join each **stage** with the correct **equipment needed**.

Stage	Equipment needed
	burette
measure mass of solid	volumetric flask
dissolve solid in water and stir	beaker and glass rod
make solution up to exactly $250\text{ cm}^3$	balance
	thermometer

[3]



- (c) Medicines that contain sodium hydrogencarbonate are used to neutralise excess acid in the stomach.

In the stomach, sodium hydrogencarbonate reacts with hydrochloric acid.

- (i) Complete the word and symbol equation for the reaction.

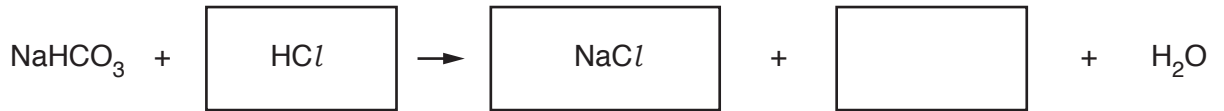

[2]

- (ii) One of the side-effects of taking medicines which contain sodium hydrogencarbonate is pain caused by a build-up of gas in the stomach.

Use the equation to explain how sodium hydrogencarbonate causes a build-up of gas in the stomach.

.....  
 .....  
 ..... [2]

[Total: 13]

2 Lemon juice contains an acid.

Joe does some titrations to find the concentration of acid in a bottle of lemon juice from a shop.

He uses a measuring cylinder to measure  $5\text{ cm}^3$  samples of lemon juice.

He adds an indicator to the lemon juice, then does a titration using dilute sodium hydroxide.

The diagram shows how he sets up his titration.

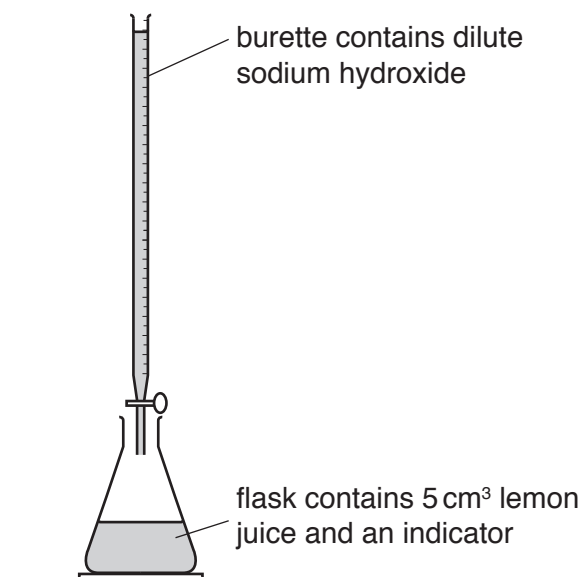

For each sample of lemon juice, Joe does a rough titration and then several titration repeats.

These are Joe's results.

	Rough	Titration repeats			
		1	2	3	4
Volume dilute sodium hydroxide used ( $\text{cm}^3$ )	25.0	24.0	26.5	27.0	19.0

(a) (i) Joe thinks that the data from his titrations is poor quality.

Explain why he is right.

.....

.....

..... [2]

- (ii) Joe thinks that his data is poor quality because the measuring cylinder does not give a precise measurement of small amounts of lemon juice.

What could Joe use to measure the lemon juice more precisely?

Put a tick (✓) in the box next to the correct answer.

- a larger measuring cylinder
- a pipette
- a small beaker
- a different indicator

[1]

- (b) Joe repeats his titrations.

These are his new results.

	Rough	Titration repeats			
		1	2	3	4
Volume dilute sodium hydroxide used (cm <sup>3</sup> )	23.0	21.0	25.0	20.5	21.5

- (i) Joe thinks one of his results is an outlier.

He ignores the outlier and uses three titration results to calculate the mean of the true volume of dilute sodium hydroxide used.

Put a ring around the **three** results in the table he uses.

[1]

- (ii) Use the results to calculate a mean for the volume of dilute sodium hydroxide.

mean = ..... cm<sup>3</sup> [2]

- (c) Joe completes similar titrations to test samples from a bottle of fruity lemon drink. The juice has this label.

Fruity drink contains <b>5%</b> lemon juice
--

Joe uses his titration results to work out a best estimate of the volume of sodium hydroxide needed.

**Best estimate = 20.0 cm<sup>3</sup>**

Joe uses the following equation to work out the concentration of the lemon juice in the drink.

$$\text{concentration of lemon juice in drink} = \frac{\text{best estimate}}{5} \%$$

Use the equation to find out if Joe's best estimate gives the same concentration of lemon juice as the label.

Explain your answer.

.....  
..... [2]

[Total: 8]

- 3 Hydrogen can be burned as a fuel. It can be made from water.

The energy level diagrams below show the energy changes when hydrogen burns and when it is made from water.

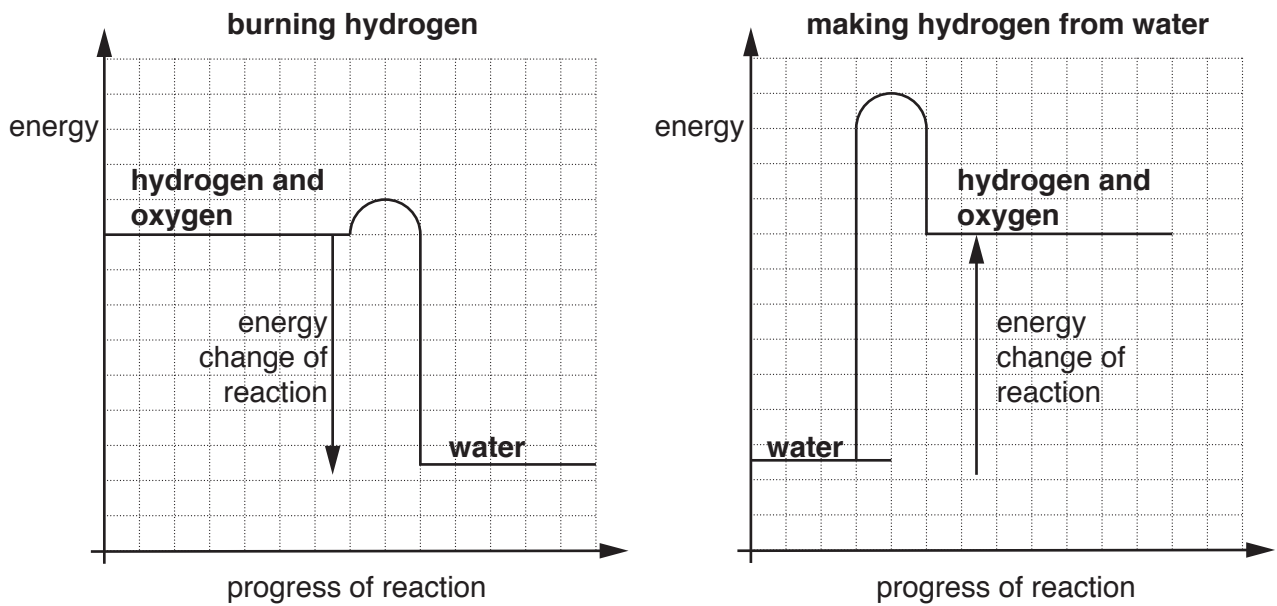

Describe and explain the **similarities** and **differences** between the energy changes shown on the two diagrams.



*The quality of written communication will be assessed in your answer.*

.....

.....

.....

.....

.....

.....

.....

.....

.....

.....

.....

[6]

[Total: 6]



**BLANK PAGE**

**PLEASE DO NOT WRITE ON THIS PAGE**

4 Octane and decane are alkanes that are used in car fuels.

(a) The diagrams show the structures of octane and decane.

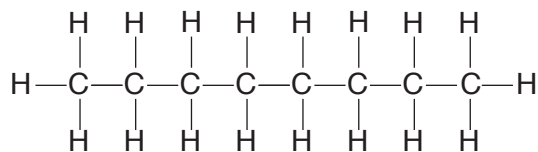

octane

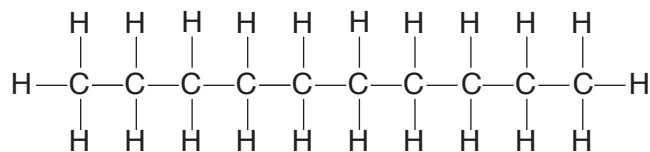

decane

(i) The formula for octane is  $\text{C}_8\text{H}_{18}$ .

Write down the formula for decane. ....

[2]

(ii) Which statements about octane and decane are **true** and which are **false**?

Put a tick (✓) in one box in each row.

	True	False
decane has a higher relative formula mass than octane		
both molecules contain double bonds		
both molecules are hydrocarbons		
both molecules give off carbon dioxide gas when they burn		

[3]

- (b) Cracking is a reaction used in a petrol refinery to make smaller molecules from long-chain alkanes.

The diagram shows what happens when cracking is used to make two molecules of ethene from an octane molecule.

One other molecule is also made.

In the box provided **draw** the structure and give the **name** of the other molecule.

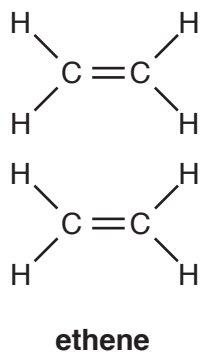
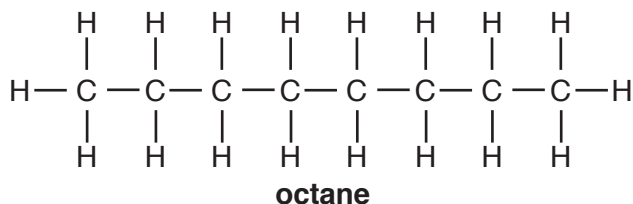

name.....

[2]

[Total: 7]

5 Ethene is used in an industrial process to make ethanol.

This is the equation for the main reaction in the process.

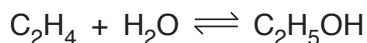

This flow diagram summarises the process.

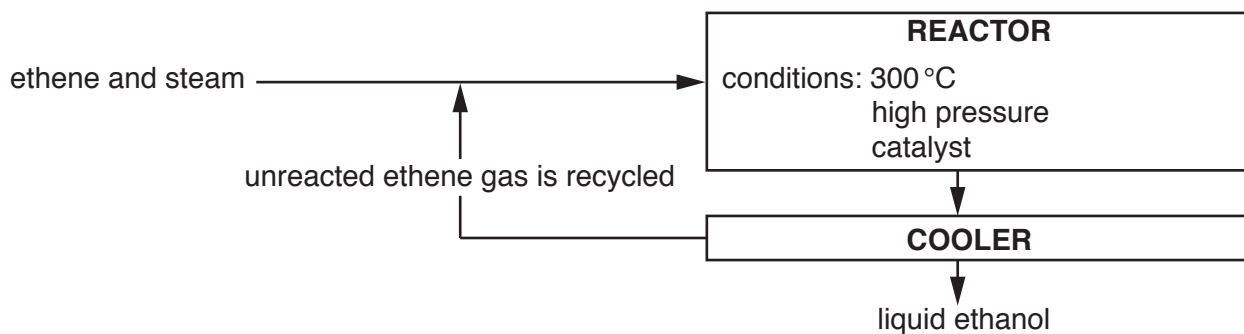

(a) What does the symbol  $\rightleftharpoons$  in the equation mean?

.....  
 .....  
 ..... [1]

(b) Explain why ethene gas needs to be recycled in the process.

.....  
 .....  
 ..... [2]

(c) How is the rate of the reaction increased during the process?

.....  
 .....  
 ..... [2]

(d) The ethanol leaves the reactor as a gas.

What happens to the ethanol so that it changes into liquid ethanol?

.....  
 .....  
 ..... [2]

(e) Ethanol can be made in other processes.

Which two processes can be used to make ethanol?

Put ticks (✓) in the boxes next to the **two** correct answers.

fermentation of sugar

using genetically modified bacteria on biomass

in the Haber process

using gas chromatography

by titration

[2]

[Total: 9]



15  
BLANK PAGE

PLEASE DO NOT WRITE ON THIS PAGE

- 7 Over 10 million tonnes of phenol are made worldwide every year. Phenol is used to make many plastic products for buildings and packaging.

Phenol has been manufactured for over 100 years. The table gives information about an older process to make phenol and a modern process.

	Older process	Modern process
<b>Raw materials</b>	Benzene (from fossil fuels) Sulfuric acid Sodium hydroxide	Benzene Propene (both from fossil fuels)
<b>Yield</b>	82%	87%
<b>Atom economy</b>	37%	100%
<b>Waste products</b>	Sodium sulfite (toxic)	None, by-products are useful
<b>Conditions</b>	High temperature and pressure	High temperature and pressure

- (a) Use the information to explain why the atom economy of the two processes are different.

.....

.....

.....

..... [2]

- (b) The modern process involves more green chemistry than the older process.

Use the information to explain why.

.....

.....

.....

..... [3]



(c) A team of scientists are investigating how to make the modern process even greener.

(i) What factors could they investigate to make the process more green?

Put ticks (✓) in the boxes next to the **two** correct answers.

Using renewable raw materials.

Using a higher temperature and pressure.

Finding more uses for phenol.

Finding ways to increase the yield of phenol.

[2]

(ii) Scientists in the team share their data with each other.

Why do they do this?

Put ticks (✓) in the boxes next to the **two** correct answers.

To make sure that other scientists do not take credit for their work.

To reduce the safety risks during their experiments.

So that other scientists can check their data.

So that they can discuss their conclusions.

To stop other scientists from working on the same idea.

[2]

(d) Some green chemical processes use enzymes as catalysts.

Which statements are **advantages** and which are **disadvantages** of using enzyme catalysts?

Put a tick (✓) in one box in each row.

	Advantage	Disadvantage
Enzymes speed up reactions		
Reactions with enzymes can work at a lower temperature		
Enzymes only work in narrow ranges of pH and temperature		
Enzymes can be denatured		

[2]

[Total: 11]

END OF QUESTION PAPER

**ADDITIONAL ANSWER SPACE**

If additional space is required, you should use the following lined page(s). The question number(s) must be clearly shown in the margin(s).

A large area of lined paper for writing. It consists of a vertical solid line on the left side, creating a margin. To the right of this line, there are numerous horizontal dotted lines spaced evenly down the page, providing a guide for writing.

A large rectangular area with a solid vertical line on the left side and horizontal dotted lines extending across the page, providing a space for writing answers.



**Copyright Information**

OCR is committed to seeking permission to reproduce all third-party content that it uses in its assessment materials. OCR has attempted to identify and contact all copyright holders whose work is used in this paper. To avoid the issue of disclosure of answer-related information to candidates, all copyright acknowledgements are reproduced in the OCR Copyright Acknowledgements Booklet. This is produced for each series of examinations and is freely available to download from our public website ([www.ocr.org.uk](http://www.ocr.org.uk)) after the live examination series.

If OCR has unwittingly failed to correctly acknowledge or clear any third-party content in this assessment material, OCR will be happy to correct its mistake at the earliest possible opportunity.

For queries or further information please contact the Copyright Team, First Floor, 9 Hills Road, Cambridge CB2 1GE.

OCR is part of the Cambridge Assessment Group; Cambridge Assessment is the brand name of University of Cambridge Local Examinations Syndicate (UCLES), which is itself a department of the University of Cambridge.

