

OCR

Oxford Cambridge and RSA

Wednesday 24 May 2017 – Morning

A2 GCE MATHEMATICS

4737/01 Decision Mathematics 2

PRINTED ANSWER BOOK

Candidates answer on this Printed Answer Book.

OCR supplied materials:

- Question Paper 4737/01 (inserted)
- List of Formulae (MF1)

Other materials required:

- Scientific or graphical calculator

Duration: 1 hour 30 minutes



Candidate forename		Candidate surname	
--------------------	--	-------------------	--

Centre number						Candidate number				
---------------	--	--	--	--	--	------------------	--	--	--	--

INSTRUCTIONS TO CANDIDATES

These instructions are the same on the Printed Answer Book and the Question Paper.

- The Question Paper will be found inside the Printed Answer Book.
- Write your name, centre number and candidate number in the spaces provided on the Printed Answer Book. Please write clearly and in capital letters.
- **Write your answer to each question in the space provided in the Printed Answer Book.** If additional space is required, you should use the lined page(s) at the end of this booklet. The question number(s) must be clearly shown.
- Use black ink. HB pencil may be used for graphs and diagrams only.
- Answer **all** the questions.
- Read each question carefully. Make sure you know what you have to do before starting your answer.
- Do **not** write in the barcodes.
- You are permitted to use a scientific or graphical calculator in this paper.
- Give non-exact numerical answers correct to 3 significant figures unless a different degree of accuracy is specified in the question or is clearly appropriate.

INFORMATION FOR CANDIDATES

This information is the same on the Printed Answer Book and the Question Paper.

- The number of marks is given in brackets [] at the end of each question or part question on the Question Paper.
- **You are reminded of the need for clear presentation in your answers.**
- The total number of marks for this paper is **72**.
- The Printed Answer Book consists of **12** pages. The Question Paper consists of **8** pages. Any blank pages are indicated.

BLANK PAGE

PLEASE DO NOT WRITE ON THIS PAGE

1 (i)

-
-
-
-
-
-
-
-

1 (ii)**1 (iii)**

2 (i)	
2 (ii)	
2 (iii)(a)	
2 (iii)(b)	
2 (iv)	

3 (i)

3 (ii)

Stage	State	Action	Weight	Working	Maximin
3	0	0	5		
	1	0	8		
2	0	0	7		
		1	4		
	2	0	4		
		1	6		
1	0	0	3		
		1	5		
	1	1	3		
		2	2		
0	0	0	6		
		1	4		

4 (i)	

4 (ii)	
4 (iii)	
4 (iv)	

5 (i)																															
5 (ii)	<table border="1" style="width: 100%; border-collapse: collapse; text-align: center;"> <tr> <td style="width: 10%;">Event</td> <td>①</td> <td>②</td> <td>③</td> <td>④</td> <td>⑤</td> <td>⑥</td> <td>⑦</td> <td>⑧</td> <td>⑨</td> </tr> <tr> <td>Early time</td> <td></td> <td></td> <td></td> <td></td> <td></td> <td></td> <td></td> <td></td> <td></td> </tr> <tr> <td>Late time</td> <td></td> <td></td> <td></td> <td></td> <td></td> <td></td> <td></td> <td></td> <td></td> </tr> </table>	Event	①	②	③	④	⑤	⑥	⑦	⑧	⑨	Early time										Late time									
Event	①	②	③	④	⑤	⑥	⑦	⑧	⑨																						
Early time																															
Late time																															
5 (iii)																															
5 (iv)	<p style="text-align: right; margin-right: 50px;">Time elapsed</p>																														

5 (v)	

5 (vi)	

6 (i)	
6 (ii)	
6 (iii)	
6 (iv)	
6 (v)	

6 (vi)

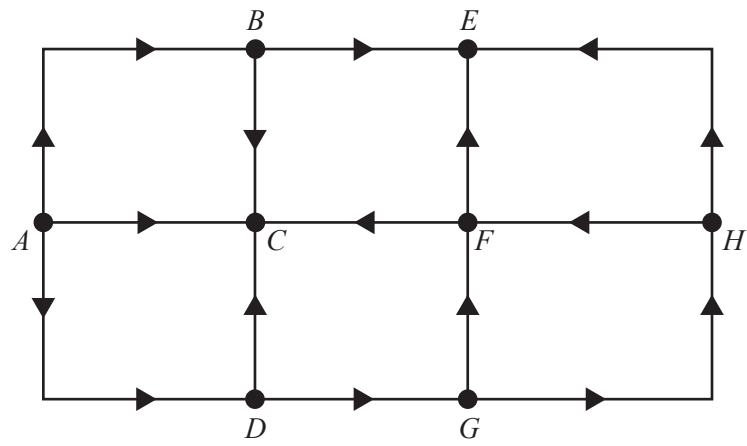

6 (vii)

Diagram if needed for working.

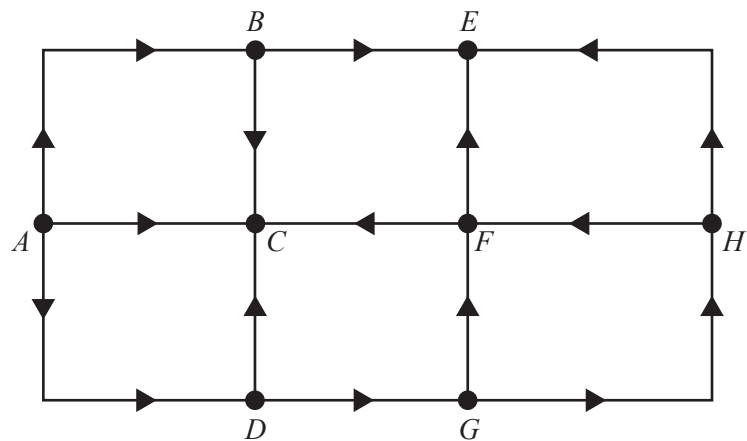

ADDITIONAL ANSWER SPACE

If additional space is required, you should use the following lined page(s). The question number(s) must be clearly shown in the margin(s).

Copyright Information

OCR is committed to seeking permission to reproduce all third-party content that it uses in its assessment materials. OCR has attempted to identify and contact all copyright holders whose work is used in this paper. To avoid the issue of disclosure of answer-related information to candidates, all copyright acknowledgements are reproduced in the OCR Copyright Acknowledgements Booklet. This is produced for each series of examinations and is freely available to download from our public website (www.ocr.org.uk) after the live examination series.

If OCR has unwittingly failed to correctly acknowledge or clear any third-party content in this assessment material, OCR will be happy to correct its mistake at the earliest possible opportunity.

For queries or further information please contact the Copyright Team, First Floor, 9 Hills Road, Cambridge CB2 1GE.

OCR is part of the Cambridge Assessment Group; Cambridge Assessment is the brand name of University of Cambridge Local Examinations Syndicate (UCLES), which is itself a department of the University of Cambridge.