

Wednesday 8 November 2017 – Afternoon

**GCSE TWENTY FIRST CENTURY SCIENCE
PHYSICS A/ADDITIONAL SCIENCE A**

A182/02 Modules P4 P5 P6 (Higher Tier)

Candidates answer on the Question Paper.
A calculator may be used for this paper.

OCR supplied materials:
None

Other materials required:

- Pencil
- Ruler (cm/mm)

Duration: 1 hour



Candidate forename		Candidate surname	
--------------------	--	-------------------	--

Centre number						Candidate number				
---------------	--	--	--	--	--	------------------	--	--	--	--

INSTRUCTIONS TO CANDIDATES

- Write your name, centre number and candidate number in the boxes above. Please write clearly and in capital letters.
- Use black ink. HB pencil may be used for graphs and diagrams only.
- Answer **all** the questions.
- Read each question carefully. Make sure you know what you have to do before starting your answer.
- Write your answer to each question in the space provided. If additional space is required, you should use the lined page(s) at the end of this booklet. The question number(s) must be clearly shown.
- Do **not** write in the barcodes.

INFORMATION FOR CANDIDATES

- The quality of written communication is assessed in questions marked with a pencil (✎).
- A list of useful relationships is printed on page 2.
- The number of marks is given in brackets [] at the end of each question or part question.
- The total number of marks for this paper is **60**.
- This document consists of **20** pages. Any blank pages are indicated.

TWENTY FIRST CENTURY SCIENCE EQUATIONS

Useful relationships

The Earth in the Universe

$$\text{distance} = \text{wave speed} \times \text{time}$$

$$\text{wave speed} = \text{frequency} \times \text{wavelength}$$

Sustainable energy

$$\text{energy transferred} = \text{power} \times \text{time}$$

$$\text{power} = \text{voltage} \times \text{current}$$

$$\text{efficiency} = \frac{\text{energy usefully transferred}}{\text{total energy supplied}} \times 100\%$$

Explaining motion

$$\text{speed} = \frac{\text{distance travelled}}{\text{time taken}}$$

$$\text{acceleration} = \frac{\text{change in velocity}}{\text{time taken}}$$

$$\text{momentum} = \text{mass} \times \text{velocity}$$

$$\text{change of momentum} = \text{resultant force} \times \text{time for which it acts}$$

$$\text{work done by a force} = \text{force} \times \text{distance moved in the direction of the force}$$

$$\text{amount of energy transferred} = \text{work done}$$

$$\text{change in gravitational potential energy} = \text{weight} \times \text{vertical height difference}$$

$$\text{kinetic energy} = \frac{1}{2} \times \text{mass} \times [\text{velocity}]^2$$

Electric circuits

$$\text{power} = \text{voltage} \times \text{current}$$

$$\text{resistance} = \frac{\text{voltage}}{\text{current}}$$

$$\frac{\text{voltage across primary coil}}{\text{voltage across secondary coil}} = \frac{\text{number of turns in primary coil}}{\text{number of turns in secondary coil}}$$

Radioactive materials

$$\text{energy} = \text{mass} \times [\text{speed of light in a vacuum}]^2$$

BLANK PAGE

PLEASE DO NOT WRITE ON THIS PAGE

Answer **all** the questions.

1 The Paralympics include events for athletes using wheelchairs.

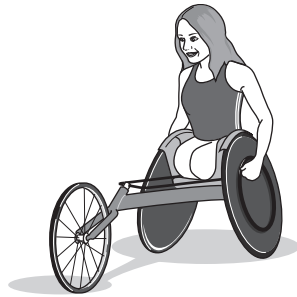

(a) During a 100 metre race, the wheelchair reaches a maximum velocity of 8 m/s.

The mass of the wheelchair is 10 kg.

(i) What is the correct way to calculate the maximum kinetic energy of the wheelchair?

Put a **ring** around the correct answer.

- 10×8 $\frac{1}{2} \times 8 \times 10$ $\frac{1}{2} \times 10 \times 8^2$ $\frac{1}{2} \times 8 \times 10^2$ [1]

(ii) The athlete does work to provide the wheelchair with this kinetic energy.

Give **two** reasons why the work done by the athlete is greater than the kinetic energy gained by the wheelchair.

- 1
-
- 2
-
- [2]

(iii) The average velocity of a wheelchair for a 100 metre race is 7 m/s.

Explain why the average velocity is less than the maximum velocity.

-
-
-
-
- [2]

(b) The graph shows how the momentum of a wheelchair and athlete changes during a race.

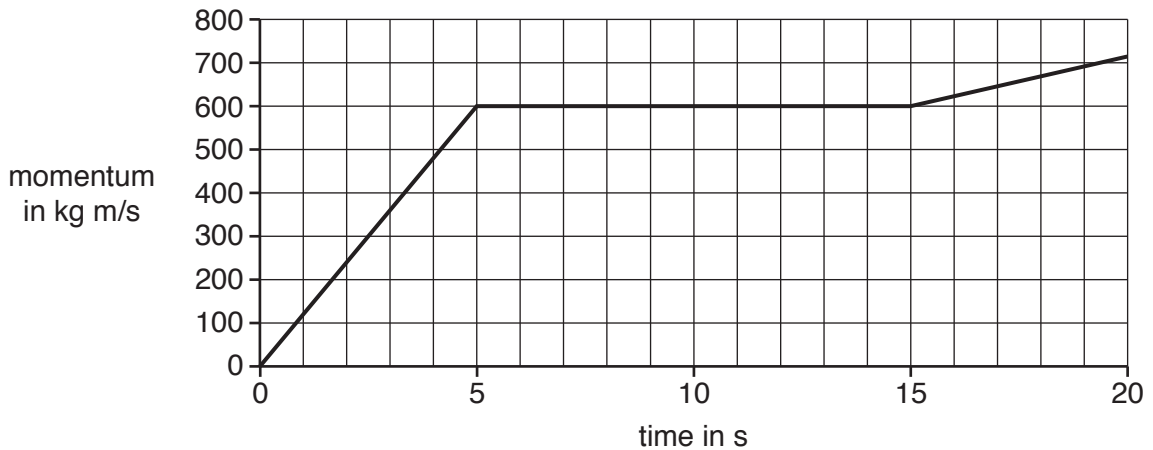

(i) Use data from the graph to calculate the resultant force acting on the wheelchair and the athlete during the first 5 seconds of the race.

Show all your working.

resultant force = N [2]

(ii) During the time interval 5 s to 15 s the momentum does not change.

Draw **one** straight line from the correct **motion statement** to the correct **force description** during this time interval.

motion statement	force description
decreasing velocity	no forces acting
constant velocity	forward force greater than backward force
increasing velocity	forward force equals backward force

[1]

(c) Suggest why knowing about counter forces on a racing wheelchair is important in its design.

.....

.....

.....

..... [2]

[Total: 10]

Turn over

2 Kassy makes a water rocket from a plastic bottle.

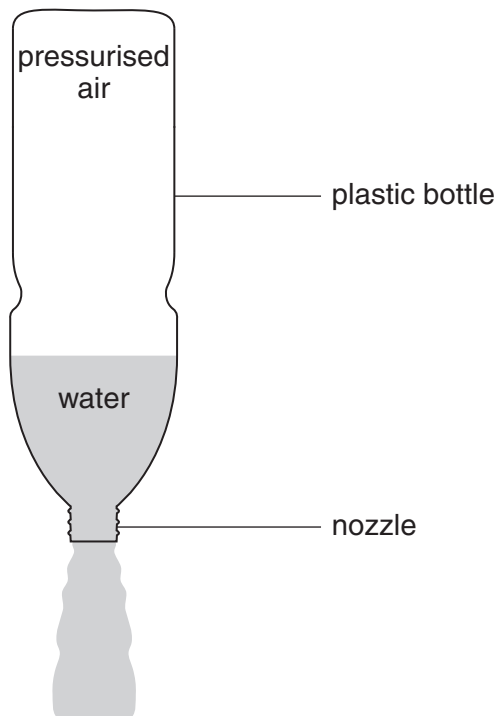

The rocket moves when pressurised air in the bottle pushes water out of the nozzle.

(a) Explain what causes the upward force on the rocket.

.....

.....

..... [2]

Kassy carried out some tests on her rocket to find out how far it would go.

She launched her rocket at an angle as shown in the diagram below.

She measured the horizontal distance travelled by the rocket.

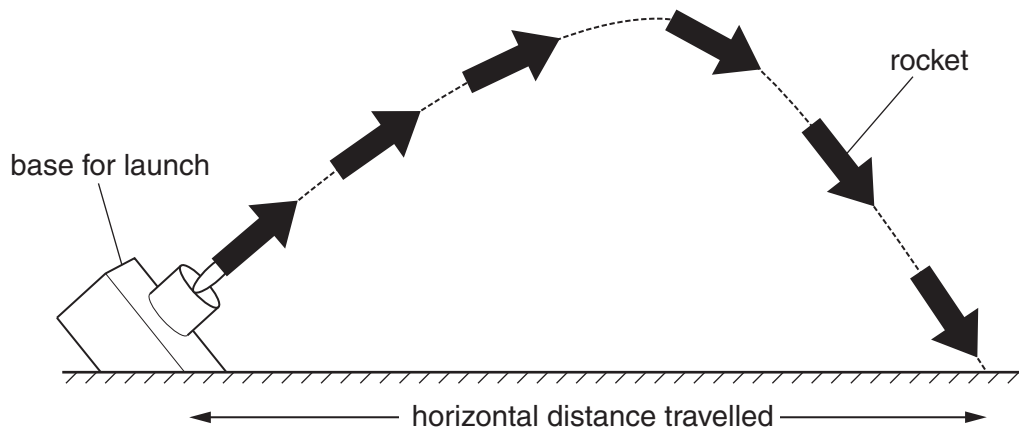

In some tests, she changed the volume of water in the rocket.

In other tests, she used different pressures for the air in the rocket.

(b) She used the same angle of launch for all the tests.

Explain why she did this.

.....
 [1]

Her results are shown in the table below.

Test	Volume of water in cm^3	Pressure of air in kPa	Horizontal distance travelled in m
1	250	210	10.0
2	250	280	11.0
3	750	280	12.5
4	750	350	13.5
5	1250	280	13.0
6	1250	420	10.5

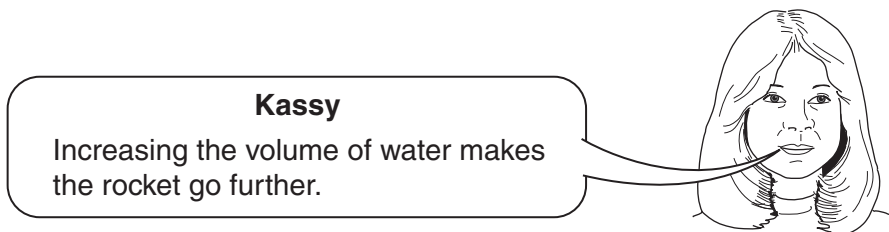

(c) Is Kassy correct?

Use data from the table to justify your answer.

.....

 [2]

[Total: 5]

BLANK PAGE

PLEASE DO NOT WRITE ON THIS PAGE

4 Dan makes a light meter using this circuit.

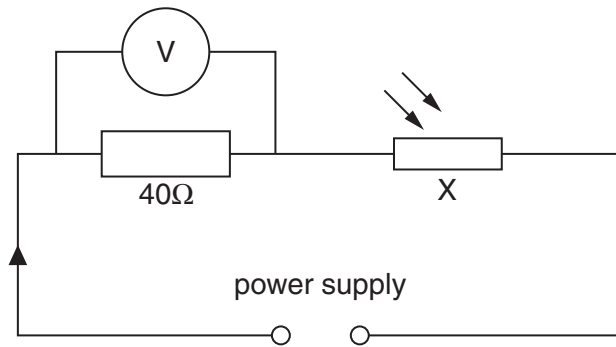

(a) What is component X?

..... [1]

(b) When Dan shines a torch on component X, the current in the circuit is 0.2A.

Calculate the reading on the voltmeter.

voltmeter reading = V [2]

(c) He now brings the torch closer to X so that more light falls on it.

The voltmeter reading increases.

Explain why the voltmeter reading increases.

.....

 [3]

(d) Dan decides to change the arrangement by connecting the resistor and X as shown below.

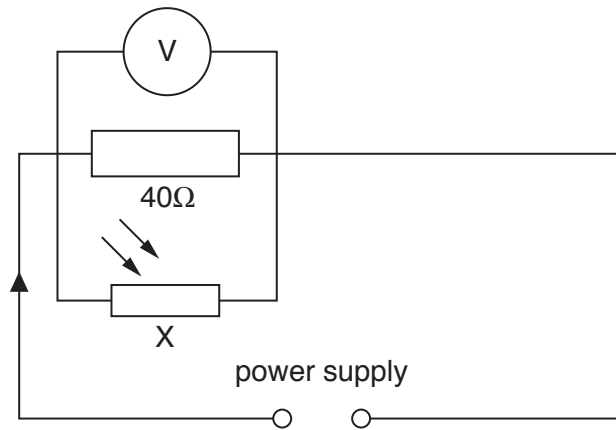

Dan
I think this arrangement will give more change in the voltmeter reading when the intensity of light shining on X increases.



Is he correct?

Give a reason for your answer.

.....

.....

..... [1]

[Total: 7]

5 Rohan wants to put new lights and an electric cooker into his kitchen.

This will need new electric cables.

He asks a qualified electrician to tell him how much these cables will cost.

The electrician gives Rohan this information.

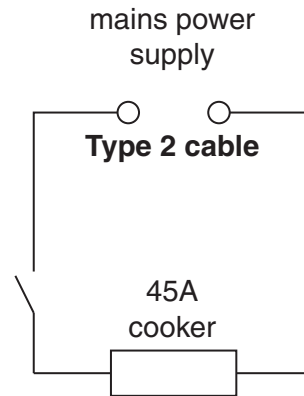
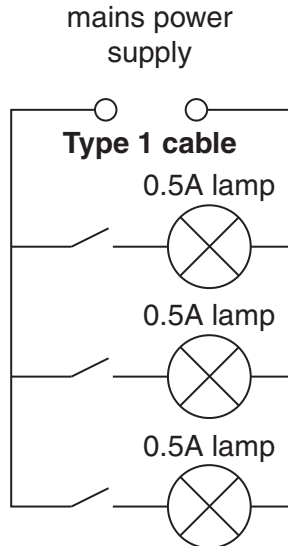

Type 1 cable
Maximum Safe Current: 14A
Cost: 30p per metre

Type 2 cable
Maximum Safe Current: 53A
Cost: £2.70 per metre

Rohan makes suggestions that are unsafe and will not work.

Rohan
We can use just Type 1 cable and connect the cooker and lamps in one series circuit. This will be cheaper.



6 Rose carries out an experiment to investigate the resistance of a piece of wire.

The wire is connected to a variable power supply.

A series of readings of voltage and current for the wire are taken by varying the output of the power supply.

(a) Complete the circuit diagram to show how an ammeter and a voltmeter should be connected.

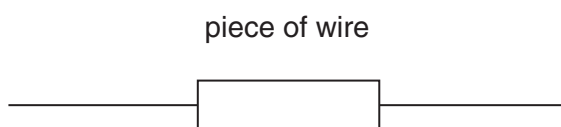
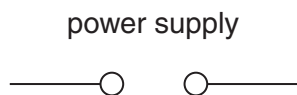

[2]

(b) She plots the voltage across the wire against the current through it.

Her graph is a **straight line** through the origin.

What can she deduce about the resistance of the wire from the graph?

.....
..... [1]

(c) Use ideas about charge to explain why the wire has resistance to an electric current.

.....
.....
.....
..... [2]

(d) The power supply is replaced by a hand turned generator.

The graph shows how the output voltage varies with time.

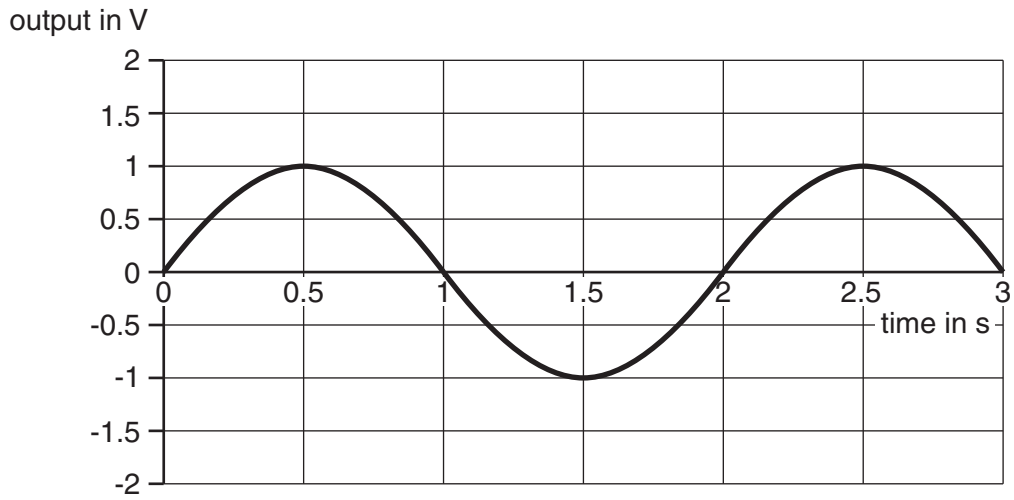

On the graph draw how the output varies when the generator is turned at **twice** the speed. [2]

[Total: 7]

8 A radioactive isotope of the element technetium is used in hospitals as a tracer for medical investigations.

(a) All isotopes of technetium have the same number of a particular particle in their nuclei. What is the name of this particle?

Put a ring around the correct answer.

electron ion neutron proton [1]

(b) All radioactive materials have a half-life.

Here are some statements about half-life.

Put a tick (✓) in the box next to the correct statement.

Half-life is half the time it takes the activity to drop to zero.

Half-life is the time it takes the activity to drop to half its value.

The half-life for the tracer can be changed by changing its temperature.

The half-life of the tracer changes with time. [1]

(c) The graph shows how the activity of a sample of technetium changes with time.

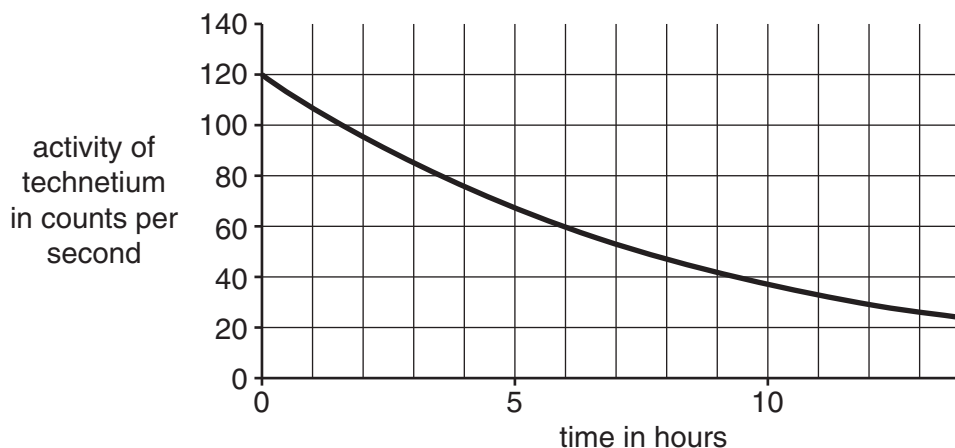

(i) Use the graph to find the half-life of the isotope.

half-life = hours [1]

(ii) Calculate the number of half-lives for the count rate to fall **below** the safe level of 10 counts per second.

number of half-lives = [1]

(d) Hospitals use ionising radiation to investigate how well a patient's kidneys are working.

(i) Radiographers carry out the tests on patients' kidneys.

They handle the tracers every working day.

They wear protective clothing.

Give two **other** ways in which radiographers are protected from receiving a high dose of ionising radiation

1

2

[2]

(ii) Radiographers are advised that their maximum yearly dose should not exceed 20 mSv.

Describe **two** factors that determine the amount of harm done to the body by the radiation it absorbs.

.....
.....

[2]

(e) Kylie has been told she needs some treatment for cancer with ionising radiation.



Kylie
I think it's too risky to use ionising radiation to treat cancers.

Kylie needs to be reassured that the treatment is worthwhile.
Discuss the risks and benefits involved in using ionising radiation to treat cancer.

.....
.....
.....
.....
.....
.....

[3]

- (f) Some of the information about the effect of radiation dose on humans has come from the accident at Chernobyl.

The nuclear power station at Chernobyl exploded and a large amount of radioactive material was released.

People living near the power station were exposed to high doses of radiation.

Suggest why scientists do not carry out investigations into the effect of high doses on humans in laboratory experiments.

.....

.....

.....

..... [2]

[Total: 13]

END OF QUESTION PAPER

ADDITIONAL ANSWER SPACE

If additional space is required, you should use the following lined page(s). The question number(s) must be clearly shown in the margin(s).

A large rectangular area with a solid vertical line on the left side and horizontal dotted lines across the rest of the page, providing space for writing answers.



Copyright Information

OCR is committed to seeking permission to reproduce all third-party content that it uses in its assessment materials. OCR has attempted to identify and contact all copyright holders whose work is used in this paper. To avoid the issue of disclosure of answer-related information to candidates, all copyright acknowledgements are reproduced in the OCR Copyright Acknowledgements Booklet. This is produced for each series of examinations and is freely available to download from our public website (www.ocr.org.uk) after the live examination series.

If OCR has unwittingly failed to correctly acknowledge or clear any third-party content in this assessment material, OCR will be happy to correct its mistake at the earliest possible opportunity.

For queries or further information please contact the Copyright Team, First Floor, 9 Hills Road, Cambridge CB2 1GE.

OCR is part of the Cambridge Assessment Group; Cambridge Assessment is the brand name of University of Cambridge Local Examinations Syndicate (UCLES), which is itself a department of the University of Cambridge.