

CAMBRIDGE TECHNICALS LEVEL 3 (2016)

Examiners' report

APPLIED SCIENCE

05847–05849, 05879, 05874

Unit 1 Summer 2023 series

Contents

Introduction	4
Unit 1 series overview	5
Question 1 (a)	6
Question 1 (b) (i)	6
Question 1 (b) (ii)	7
Question 1 (b) (iii)	7
Question 1 (c) (i)	8
Question 1 (c) (ii)	8
Question 1 (d) (i)	9
Question 1 (d) (ii)	9
Question 2 (a) (i)	10
Question 2 (a) (ii)	11
Question 2 (b) (i)	12
Question 2 (b) (ii)	13
Question 2 (b) (iii)	13
Question 2 (c) (i)	14
Question 2 (c) (ii)	14
Question 2 (d) (i)	15
Question 2 (d) (ii)	15
Question 2 (d) (iii)	15
Question 3 (a) (i)	16
Question 3 (a) (ii)	17
Question 3 (a) (iii)	18
Question 3 (b) (i)	19
Question 3 (b) (ii)	19
Question 3 (b) (iii)	20
Question 3 (b) (iv)	21
Question 3 (b) (v)	21
Question 3 (c) (i)	22
Question 3 (c) (ii)	22
Question 3 (d)	23
Question 4 (a)	24
Question 4 (b) (i)	25
Question 4 (b) (ii)	26

Question 4 (b) (iii)27

Question 4 (c) (i)27

Question 4 (c) (ii)28

Question 4 (c) (iii).....28

Question 4 (d) (i).....29

Question 4 (d) (ii)30

Question 4 (d) (iii)31

Question 4 (d) (iv)32

Question 533

Question 6 (a) (i).....34

Question 6 (a) (ii)34

Question 6 (b) (i).....35

Question 6 (b) (ii)36

Question 6 (b) (iii)36

Question 7 (a) (i).....37

Question 7 (a) (ii)38

Question 7 (a) (iii)38

Question 7 (a) (iv)39

Question 7 (b)40

Copyright information41

Introduction

Our examiners' reports are produced to offer constructive feedback on candidates' performance in the examinations. They provide useful guidance for future candidates.

The reports will include a general commentary on candidates' performance, identify technical aspects examined in the questions and highlight good performance and where performance could be improved. The reports will also explain aspects which caused difficulty and why the difficulties arose, whether through a lack of knowledge, poor examination technique, or any other identifiable and explainable reason.

Where overall performance on a question/question part was considered good, with no particular areas to highlight, these questions have not been included in the report.

A full copy of the question paper and the mark scheme can be downloaded from OCR.

Would you prefer a Word version?

Did you know that you can save this PDF as a Word file using Acrobat Professional?

Simply click on **File > Export to** and select **Microsoft Word**

(If you have opened this PDF in your browser you will need to save it first. Simply right click anywhere on the page and select **Save as . . .** to save the PDF. Then open the PDF in Acrobat Professional.)

If you do not have access to Acrobat Professional there are a number of **free** applications available that will also convert PDF to Word (search for PDF to Word converter).

Unit 1 series overview

It was clear that a number of candidates were prepared for this paper. Many of the topic areas listed in the specification had been encountered and candidates had the opportunity to display the skills and knowledge required to succeed at this standard. Some candidates were challenged by a range of questions and did not complete a response. In this context, no question or item could be identified as a pattern for such 'nil responses'. The rubric of the paper did not present a problem for the majority of candidates and most completed the paper.

As was observed for the January 2023 series, most candidates were capable of following the instructions for the level of response (LoR) question (Question 5). Almost all candidates were able to achieve marks for this question at Level 1. A number of candidates did well and progressed onto Level 2 and some achieved Level 3 with full marks.

The objective-format items, including the addition of missing words within sentences, completing tick-boxes against optional statements, completing tables and joining concept boxes with lines enabled candidates to show a good level of understanding. On occasion, candidates did not make the most of the working space provided for calculations. As for earlier series of this paper, this prevented them from gaining the calculation marks in the absence of the correct final response.

Very few candidates used the extra page provided at the end of the paper. However, when candidates followed this option, they correctly linked the page to the relevant item within the paper content.

Candidates who did well on this paper generally:	Candidates who did less well on this paper generally:
<ul style="list-style-type: none"> • appeared to have revised and prepared well for the examination, and their knowledge reflected the details shown in the 'exemplification' part of the specification • generally understood the basics of inorganic and organic chemistry, using correct symbols and terminology • were much more clearly able to respond to the biology-related topics encountered • accessed a range of objective formats and applied the rubric of the question paper to good effect • responded well to data presented as graphs and images to identify trends • effectively used the information given via the stems of questions to demonstrate their skills and knowledge • interacted well with the LoR question, including the correct completion of the calculations required. 	<ul style="list-style-type: none"> • did not appear to revise or prepare for the examination at the required level and were unable to show their knowledge of the 'exemplification' part of the specification • seemed to struggle with inorganic and organic chemistry, including the Periodic Table • struggled to respond to a number of items, including the biology-related topics • tended not to interpret the rubric of the question paper, including sentence-completion items • were challenged by the presentation of data as graphs and images, including the identification of trends • misinterpreted information given in the stem of questions • did not effectively interact with the data presented for the LoR question and struggled to complete the calculations required.

Question 1 (a)

- 1 The table shows some of the atomic properties of elements **Q**, **R**, **S** and **T** in the Periodic Table.

The letters **Q** to **T** are **not** the chemical symbols of the elements.

Element	Electron configuration	Group number	Proton number	Relative atomic mass
Q	2,1	3
R	3	27.0
S	2,8,4	28.1
T	1	19

- (a) Use the Periodic Table to complete the table.

[4]

Almost all candidates completed this item correctly. Not clear pattern of errors could be identified.

Question 1 (b) (i)

- (b) (i) Give the name of the element in period 5 which is in the same group as element **T**.

..... [1]

Most candidates successfully identified rubidium as the element in period 5. This showed a good understanding of the Periodic Table.

Misconception



A few candidates did show a common misconception and selected arsenic instead of rubidium.

Question 1 (b) (ii)

(ii) Element T forms an ionic bond with chlorine.

Describe how this ionic bond is formed.

.....

.....

.....

.....

.....

..... [2]

A number of candidates were confident with their understanding of the ionic bond and recalled that one electron is lost from element T (potassium) and given to chloride (Cl). Very few candidates outlined the attraction between positive and negative ions.

Question 1 (b) (iii)

(iii) Give **two** reasons why chlorine, bromine and iodine are placed in the same group in the Periodic Table.

1

2

[2]

It was clear that many candidates appreciated that chlorine, bromine and iodine have the same (7) number of electrons in their outer shell. Some also understood that they shared chemical properties or reactions.

Misconception

 A number of candidates incorrectly assumed that ionic bonds were a product of the interaction between metals and non-metals.

Question 1 (c) (i)

(c) Water is a covalent compound.

(i) Draw the dot-and-cross diagram to show the bonding in water by completing the figure below.

Show outer electrons only.

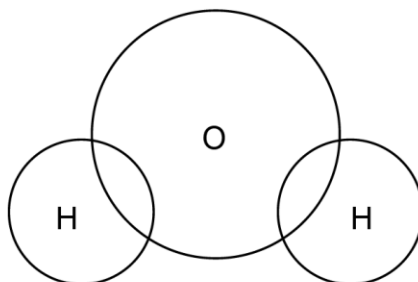

[2]

In general, this item did not present a challenge for candidates. They were able to draw a dot and cross in the two regions of overlap and two further crosses/dots in the outer shell of oxygen.

Assessment for learning



It will be useful for candidates to fully understand that it is not appropriate to draw the dots and crosses on the lines at the point of overlap, but should rather be drawn within the space.

Question 1 (c) (ii)

(ii) Water is an example of a polar solvent.

Explain why water is polar.

.....

.....

..... [1]

Many candidates struggled to articulate a clear response for this explanation. No clear pattern of errors was observed.

Question 1 (d) (i)

(d) The heaviest isotope of hydrogen is called tritium. Its symbol is ${}^3_1\text{H}$.

Tritium is radioactive and decays to form helium-3, ${}^3_2\text{He}$.

(i) Name the type of nuclear force which allows a tritium nucleus to decay.

..... [1]

Although many candidates correctly understood that weak nuclear forces allow a tritium nucleus to decay, some provided incorrect responses, ranging from strong nuclear force to electromagnetic force. Again, no clear pattern of errors could be identified.

Question 1 (d) (ii)

(ii) Tritium and helium-3 nuclei both have three nucleons.

Explain in terms of the nucleons present why they are different elements.

.....
.....
..... [2]

Many candidates obtained 1 out of the 2 marks available because they recalled that tritium and helium-3 have different numbers of protons. Few candidates provided details of the numbers of proton and neutrons involved or considered the atomic numbers.

Question 2 (a) (i)

2 (a) The diagram shows a bacterial cell, *Bacillus coagulans*.

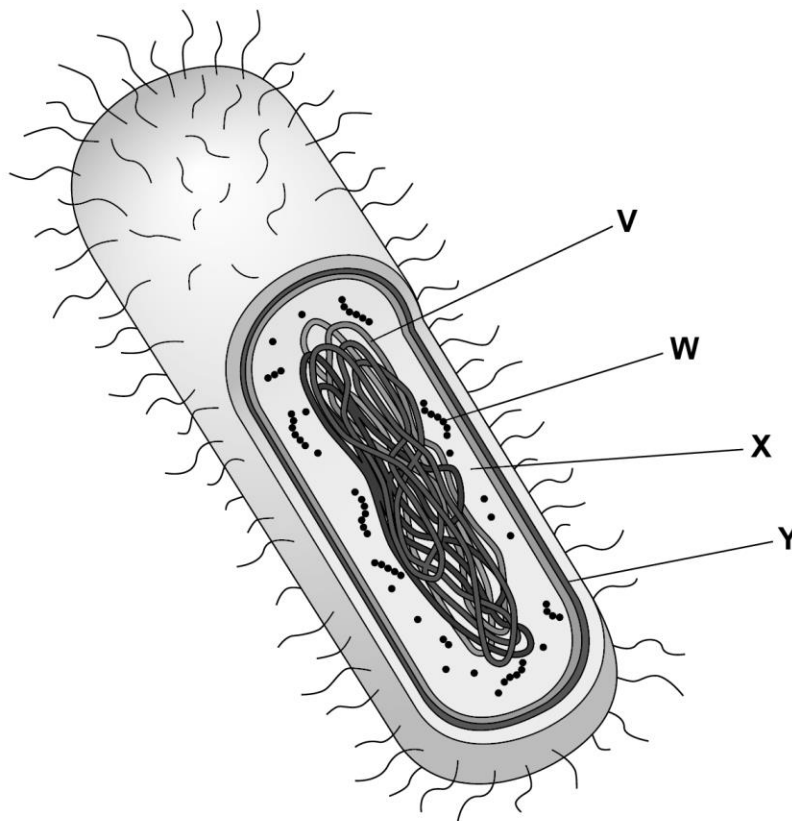

(i) Identify **V**, **W**, **X** and **Y** in the diagram from the following list.

- | | | | |
|------------------|------------------|------------|-----------------|
| cell wall | cytoplasm | DNA | ribosome |
|------------------|------------------|------------|-----------------|

V =

W =

X =

Y =

[2]

This item enabled almost all candidates to show what they know about the components of a bacterial cell. No pattern of errors could be identified.

Question 2 (a) (ii)

(ii) *Bacillus coagulans* is a prokaryotic cell.

Give **one** piece of evidence from the diagram which supports the fact that *Bacillus coagulans* is a prokaryotic cell.

.....
..... [1]

Again, this item was very accessible for almost all candidates. Most noted that prokaryotic cells lack a (true) nucleus. Others successfully described the DNA loop.

Assessment for learning



Some candidates referred to 'cell wall'. This is not a characteristic solely of prokaryotic cells because eukaryotic cells such as those in plants and fungi also have a cell wall. Students should be encouraged to make a more detailed comparison of prokaryotic versus eukaryotic cells, perhaps via the construction of a table of characteristic features.

Question 2 (b) (i)

(b) The genetic information held within DNA is copied by the processes of transcription and translation.

(i) Draw straight lines to connect each process with the correct molecule formed.

Process	Molecule formed
transcription	carbohydrate
translation	lipid
	mRNA
	protein
	tRNA

[2]

Many candidates successfully linked transcription to mRNA. They were less confident with the molecule formed at translation.

Misconception



There was a misconception that tRNA was formed at translation. It should be appreciated that although tRNA is actively involved in the process of translation, the product is protein.

Question 2 (b) (ii)

(ii) DNA is also found in eukaryotic cells.

The DNA in a eukaryotic cell is different from the DNA in a prokaryotic cell.

For a **eukaryotic cell**, describe:

- where the DNA is located
- the form in which DNA is found
- how the DNA is prevented from moving freely around the cell.

.....

.....

.....

.....

.....

.....

.....

.....

.....

.....

[3]

A number of candidates found this item to be very accessible and correctly noted that DNA is found in the nucleus as a double-helix, in the form of chromosomes or chromatin. However, only some candidates fully appreciated that the DNA is prevented from moving freely around the cell by the nuclear membrane/envelope. It was interesting to see that some candidates were also able to describe the role of nuclear pores in this process.

Question 2 (b) (iii)

(iii) State the function of the nucleolus found in eukaryotic cells.

..... [1]

This item was challenging for most candidates. They tended to refer to the nucleolus as the site of DNA, without stating the function of ribosome synthesis.

Assessment for learning

 The role of the nucleolus is outlined in the specification at **LO 3.2**

Question 2 (c) (i)

(c) In eukaryotic organisms, a unique combination of DNA is formed during the process of sexual reproduction.

This takes place when a female sex cell is fertilised by a male sex cell.

(i) What name is given to a sex cell?

Tick (✓) **one** box.

- erythrocyte
- gamete
- neuron
- osteocyte

[1]

This was a mostly accessible item for almost all candidates. It was widely understood that gametes and sex cells. No clear pattern of errors could be identified.

Question 2 (c) (ii)

(ii) The reproductive organs that produce sex cells are known as gonads.

Choose the correct words from the list to complete the sentences below.

- oocytes ovaries sperm testes**

Male gonads are known as

Female gonads produce

[2]

Almost all candidates understood that male gonads are known as testes. However, not all appreciated that female gonads produce oocytes.

Misconception

?

It is assumed that candidates misinterpreted the rubric of the item and did not appreciate that female gonads (ovaries) 'produce' oocytes.

Question 2 (d) (i)

(d) Connective tissue is found in male and female gonads.

(i) State the name of **one** of the two types of fibres in connective tissue.

..... [1]

A number of candidates correctly stated the names of fibres in connective tissue as elastic (elastic) or collagen. However, many struggled and provided a wide range of responses including myosin.

Question 2 (d) (ii)

(ii) The connective tissue fibres are produced by a special type of cell.

Give the name of this cell.

..... [1]

Very few candidates correctly understood that fibrocytes (or their precursor cells, fibroblasts) are responsible for producing the connective tissue fibres. Incorrect responses ranged from sex cell to hepatocyte and muscle cell.

Assessment for learning



Candidates should be encouraged to explore the structure of connective tissue in more detail. It is recommended that the construction of a simple, annotated diagram would be sufficient for this process.

Question 2 (d) (iii)

(iii) Suggest a function of connective tissue in the gonads.

..... [1]

Many candidates correctly recalled that connective tissue binds structures together or supports such structures within organs, including within the gonads. Some candidates were somewhat challenged by this and incorrectly described this tissue as the site of gamete production or movement.

Question 3 (a) (i)

3 Esters are organic compounds of commercial and biological importance and have the functional group:

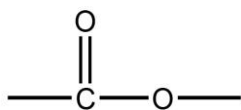

(a) Fig. 3.1 shows an equation for the reaction of a carboxylic acid to form an ester.

Fig. 3.1

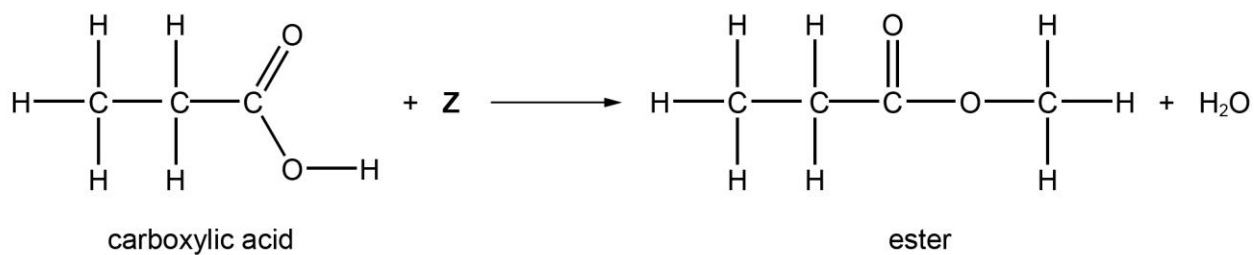

(i) Identify the type of organic compound represented by Z in Fig. 3.1.

Tick (✓) **one** box.

alcohol

aldehyde

alkyne

ketone

[1]

Many candidates correctly selected alcohol as the type of organic compound represented by Z in Fig. 3.1. Not clear pattern of alternative selections was identified.

Question 3 (a) (ii)

(ii) Give the name of the ester in **Fig. 3.1**.

Tick (✓) **one** box.

ethyl methanoate

ethyl propanoate

methyl propanoate

propyl methanoate

[1]

Some candidates correctly identified methyl propanoate as the name of the ester in **Fig. 3.1**. Although no definite pattern of errors was observed, there was a tendency for candidates to incorrectly select ethyl propanoate.

Question 3 (a) (iii)

- (iii) The ester in **Fig. 3.1** has the molecular formula $C_4H_8O_2$ and has other structural isomers.

Draw the structural formula for one isomer that is a carboxylic acid and one isomer that is a **different** ester.

carboxylic acid
ester

[3]

Although many candidates confidently constructed the formula of the carboxylic acid, most struggled with the formula of the ester. However, some did obtain one mark for correctly drawing part of the structure of the ester. No clear pattern of errors was identified for responses to the ester.

Question 3 (b) (i)

- (b) Lactic acid is a naturally occurring carboxylic acid which is used to produce the polymer polylactate.

The skeletal formula of lactic acid is shown in Fig. 3.2.

Fig. 3.2

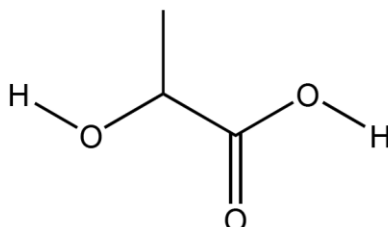

Lactic acid shows optical isomerism because it has a chiral centre.

- (i) Draw a **circle** round the chiral centre in Fig. 3.2 and explain why it is a chiral centre.

.....
 [2]

Although some candidates responded correctly to this item, many incorrectly drew a circle around the part of the skeletal formula containing the double bond. Such candidates often incorrectly stated that the double bond characterised the chiral centre.

Assessment for learning



It is recommended that the characteristic feature of the chiral centre (an atom with four different groups attached to it) should be reinforced, perhaps via simple models.

Question 3 (b) (ii)

- (ii) There are two optical isomers of lactic acid.

Describe the difference between the two optical isomers.

.....

 [1]

Very few candidates referred to 'mirror images' within their response to this item. No clear pattern of alternative responses could be identified.

Question 3 (b) (iii)

- (iii) Polylactate is a type of polymer known as a polyester. The skeletal formula of two units of polylactate is shown in **Fig. 3.3**.

Fig. 3.3

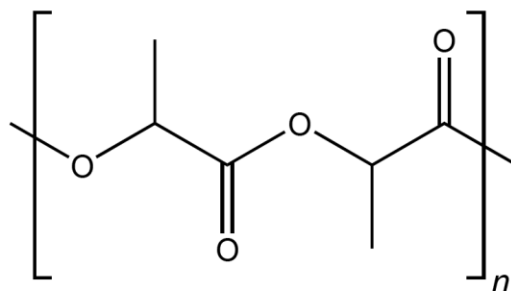

Circle the ester link in **Fig. 3.3** to show that polylactate is an example of a polyester.

[1]

A number of candidates successfully drew a circle around the ester link in **Fig. 3.3**. No clear pattern of alternative responses was identified.

Question 3 (b) (iv)

- (iv) Polylactate is increasingly being used to replace plastics derived from crude oil such as polypropene.

The skeletal formula of propene is shown below.

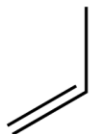

Draw the skeletal formula of **two** units of polypropene.



[1]

This was a challenging item. Relatively few candidates were able to draw the skeletal formula correctly. There appeared to be a lack of familiarity with the construction of skeletal formulae.

OCR support



A list of polymers linked to structural and skeletal formulae is outlined in the specification at **LO 4.2.**

Question 3 (b) (v)

- (v) Polylactate and polypropene are formed by different types of polymerisation reaction. Identify the type of reaction that forms each polymer.

Polylactate

Polypropene

[2]

Some candidates were able to state that polylactate is formed due to a condensation reaction and polypropene by an addition reaction. No clear pattern of errors was observed.

Question 3 (c) (i)

(c) Lactic acid is made from fermented plant starch.

Part of the structure of starch is shown below.

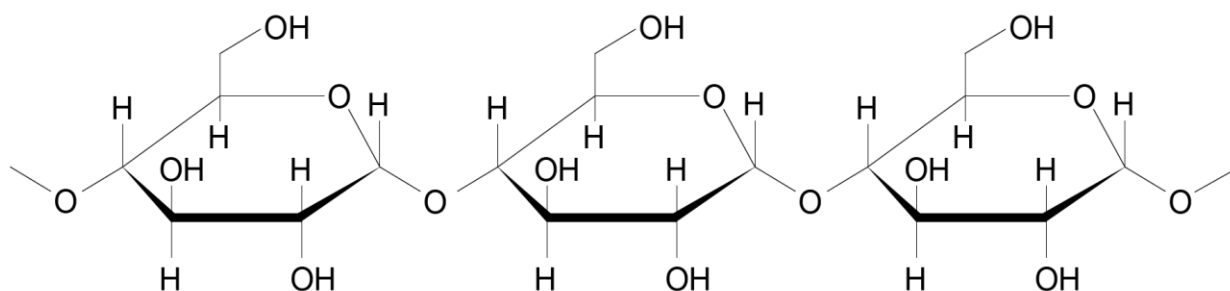

(i) The first stage of the fermentation process involves the breakdown of starch into its monomers.

Identify the name of the monomer formed from this process.

Tick (✓) **one** box.

fructose

glucose

lactose

sucrose

[1]

Most candidates understood that starch is composed of the monomer, glucose. No pattern of incorrect responses was identified.

Question 3 (c) (ii)

(ii) Starch has a specific function within a plant.

State the main function of starch.

..... [1]

Some candidates correctly appreciated that the function of starch is as an energy store/supply or glucose store. Other candidates found this topic to be challenging. No pattern of incorrect responses was observed.

Question 3 (d)

(d) Lipids are biological molecules which also contain an ester group.

Lipids form part of the myelin sheath in the human body.

Explain the function of the myelin sheath.

.....

.....

.....

.....

.....

..... [3]

Some candidates were very confident in relation to this topic and provided a good account of the myelin sheath around the nerve cell/neuron axon; the insulating property and the impact on speeding up the rate of nerve impulse transmission.

Assessment for learning

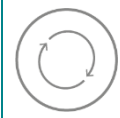

It is recommended that the appearance and role of the myelin sheath on neuron axons is appreciated more fully via the construction of a simple, annotated model.

Question 4 (a)

4 Inorganic compounds play an important role in biological processes.

(a) Choose the correct words from the list to complete the sentences below.

degradation

hydrolysis

metabolism

photolysis

Hydrogen peroxide is produced during the of organic molecules, such as amino acids.

Hydrogen peroxide is removed by in the liver.

[2]

A number of candidates obtained both marks for correctly identifying the metabolism of molecules linked to the production of hydrogen peroxide and the removal of this compound by degradation in the liver.

OCR support



This process is outlined in the specification at **LO 5.1**.

Question 4 (b) (i)

(b) Potassium nitrate is an important fertiliser.

- (i) The first stage in its manufacture is the Haber Process in which nitrogen from the air is reacted with hydrogen. The reaction is carried out in the presence of an iron catalyst as shown in the equation.

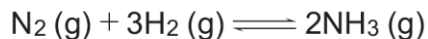

State one economic benefit of using a catalyst and explain how a catalyst increases the rate of reaction.

Benefit

.....
.....

Explanation of how a catalyst increases reaction rate

.....
.....
.....

[3]

Although many candidates understood that catalysts lower activation energy, relatively few linked this to reduced energy costs and thus an economic benefit. However, some candidates did appreciate that the reuse of catalysts was a factor. No clear pattern of alternative responses were noted, with the exception of a general comment, indicating that catalysts were cheap to buy.

Question 4 (b) (ii)

(ii) Ammonia is then converted to nitric acid as shown in the equation.

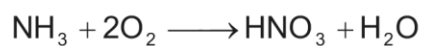

What type of reaction is shown in the equation?

Tick (✓) **one** box.

addition

condensation

displacement

redox

[1]

Some candidates correctly selected 'redox' as the type of reaction involved in the conversion of ammonia to nitric acid. The other options appeared to be selected at random.

Question 4 (b) (iii)

(iii) Nitric acid is then converted into potassium nitrate for use in inorganic fertilisers. What is the formula of potassium nitrate?

Tick (✓) **one** box.

P_2NO_2	<input type="checkbox"/>
KNO_2	<input type="checkbox"/>
KNO_3	<input type="checkbox"/>
PNO_3	<input type="checkbox"/>

[1]

Many candidates were confident when presented with the options for the formula of potassium nitrate.

Misconception



A number of candidates incorrectly selected KNO_2 (rather than KNO_3) probably due to the presence of K in the formula.

Question 4 (c) (i)

(c) Plants absorb nitrates from the soil and use these to make proteins.

The equation shows the stages which occur when a plant converts nitrates into proteins.

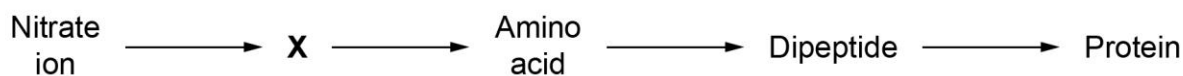

(i) Give the name of the ion **X** in the process.

..... [1]

Although some candidates correctly named the ion as ammonium, many struggled with this item and presented a range of responses but with no clear trend. A response of 'ammonia' was not acceptable for this item.

Question 4 (c) (ii)

(ii) Glycine is an amino acid. It has the formula $\text{H}_2\text{NCH}_2\text{COOH}$.

Complete the equation to show the structure of the dipeptide produced when two glycine molecules react together.

Your dipeptide structure should clearly show the peptide link.

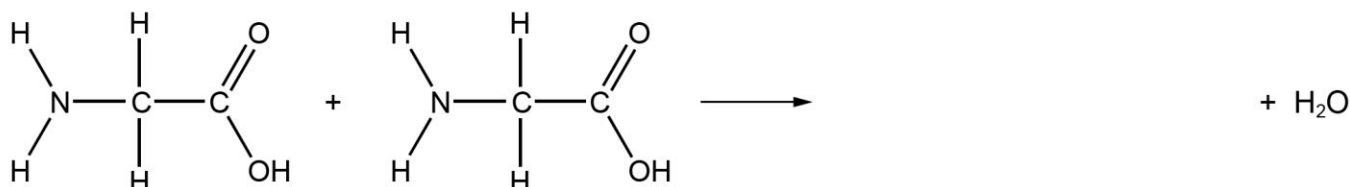

[2]

Many candidates were also challenged by the construction of the dipeptide. Some did obtain one mark for the arrangement of atoms on either side of the peptide bond but drew the bond incorrectly.

Assessment for learning



It is recommended that candidates gain greater familiarity with the construction of dipeptides involving a range of amino acid combinations. This could be reinforced via diagrammatic models.

Question 4 (c) (iii)

(iii) Give **one** function of proteins in plant cells.

..... [1]

The most successful candidates recognised that proteins function in cells for support (via the cytoskeleton) or as receptors (within the cell membranes). Very few identified the role of proteins as enzymes.

Misconception



However, many candidates incorrectly considered that proteins were a source of energy.

Question 4 (d) (i)

(d) Phosphorus is often found as phosphates in living things. Phosphates have important structural functions in DNA and in phospholipids.

(i) Phosphates create a structural bridge in DNA.

Identify the correct structural sequence involving phosphate within DNA.

Tick (✓) **one** box.

base – phosphate – base

base – phosphate – sugar

sugar – phosphate – base

sugar – phosphate – sugar

[1]

Some candidates made the correct conclusion that phosphates provide the link between adjacent (deoxyribose) sugars along the chain of mononucleotides within the DNA molecule. No clear pattern of errors was observed.

Assessment for learning



It is suggested that candidates study the arrangement of nucleotides along the DNA double-helix in more detail, again via simple models. Although many images of DNA are available via the internet, the construction of the double-helix using kits is also recommended for this purpose.

Question 4 (d) (ii)

(ii) The diagram shows the incomplete structure of a phospholipid.

Complete the diagram of the phospholipid by:

- drawing in the bonds between the phosphorus and oxygen atoms
- writing in the ionic charge in the box next to the structure.

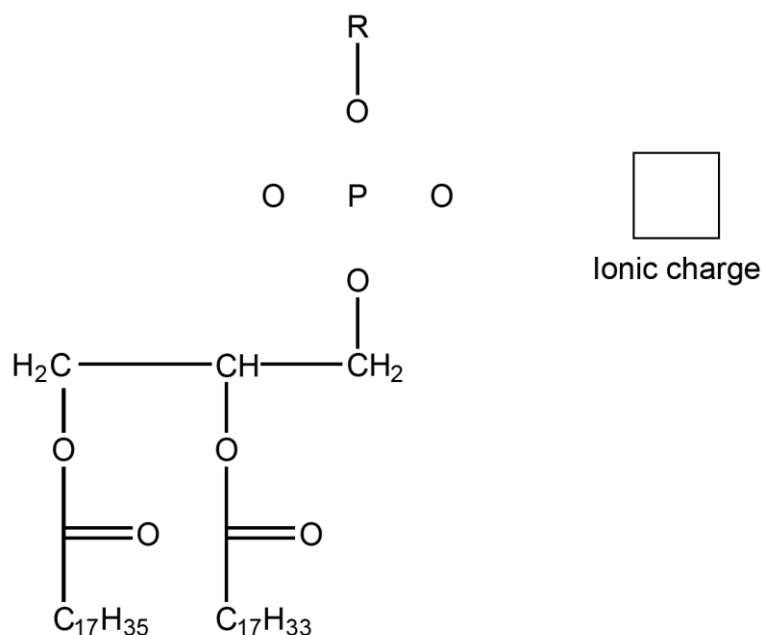

[2]

Relatively few candidates correctly drew a double bond between one of the oxygen atoms (on the left or right hand side of the diagram) with the phosphate. The resulting negative ionic charge (expressed as -, -1 or 1-) was rarely seen.

Question 4 (d) (iii)

- (iii) The R group in the phospholipid in the diagram is called choline.
Identify the metal ion that is involved in the biosynthesis of choline.

Tick (✓) **one** box.

calcium ion

lithium ion

manganese ion

nickel ion

[1]

Many candidates correctly selected manganese ion as the ion involved in the biosynthesis of choline. No clear trend of alternative responses was observed.

Assessment for learning



The biological functions of various metal ions are outlined in the specification at **LO 5.1**.

Question 4 (d) (iv)

(iv) Phospholipids form bilayers in cellular membranes.

These membranes are surrounded on either side by a fluid which consists mainly of water.

Choose the correct words from the list to complete the sentences below.

- | | | | | | |
|------------------|----------------|--------------------|--------------------|------------------|---------------|
| cellulose | DNA | hydrophilic | hydrophobic | inside | middle |
| non-polar | outside | polar | protein | uncharged | |

The bilayer of phospholipids is permeable to molecules that are small and

.....

The phosphate head of each phospholipid molecule is facing the

..... of the cell membrane.

This is because the phosphate head is

The phospholipid bilayer also containsmolecules.

[3]

A number of candidates did well with this item and obtained 2 or 3 marks. A common error was to identify the bilayer of phospholipids as uncharged, rather than non-polar. Many candidates were given 1 mark for recalling that the phosphate head of the phospholipids was hydrophilic.

Question 5

5 A useful measure of the strength of a material is its stiffness, S .

Stiffness is the ratio of the Young's Modulus of the material to the density of the material.

S is calculated using the equation:

$$S = \frac{E}{\rho} \text{ where } E \text{ is the Young's Modulus of the material and } \rho \text{ is its density.}$$

The table shows the values of E and ρ for an alloy of aluminium and an alloy of steel.

	aluminium alloy	steel alloy
Young's Modulus E (N m^{-2})	71×10^9	190×10^9
Density ρ (kg m^{-3})	2820	7980

Use calculations to compare the stiffness (S), density (ρ) and Young's Modulus (E) of these alloys and explain which alloy is more suitable for making a racing bike handlebar as shown below.

[6]



In general, this level of response (LoR) item was accessible for many candidates. They achieved marks at Level 2 or even higher. The most commonly identified valid points were linked to the correct calculation for the stiffness of the two alloys. Many candidates progressed to link the suitability of either alloy as a material for the racing bike handlebar. Some responses were particularly clear, with explanations ranging from a comparison of density, strength, weight and Young's modulus.

Question 6 (a) (i)

6 (a) A mixture is a substance in which the particles of one component are dispersed throughout the other.

(i) Types of mixture include:

colloids

solutions

suspensions

Write the name of each of the three mixture types to complete the figure below.

Put them in order of **increasing** particle size of the dispersed component.

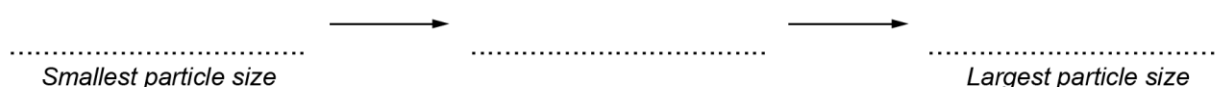

[1]

Some candidates found this item to be very accessible and correctly recalled that solutions have the smallest particle size with suspensions formed from mixtures with large particle sizes. No clear pattern of alternative responses was recorded.

Question 6 (a) (ii)

(ii) Colloids are classified according to the physical states of the dispersed phase and the disperse medium.

Draw straight lines to connect each description to the type of colloid.

Description

Type of colloid

gas dispersed in a liquid

aerosol

emulsion

foam

liquid dispersed in a gas

gel

sol

[2]

Many candidates correctly linked liquids dispersed in a gas to 'aerosol'. Others were less certain about gases dispersed in a liquid, and thereby selected 'gel' or 'sol' rather than 'foam'.

Question 6 (b) (i)

(b) Alloys such as solder are mixtures of metals.

Solder is a mixture of lead and tin.

The graph shows how the melting point of solder changes as the percentage by mass of tin in the mixture is increased.

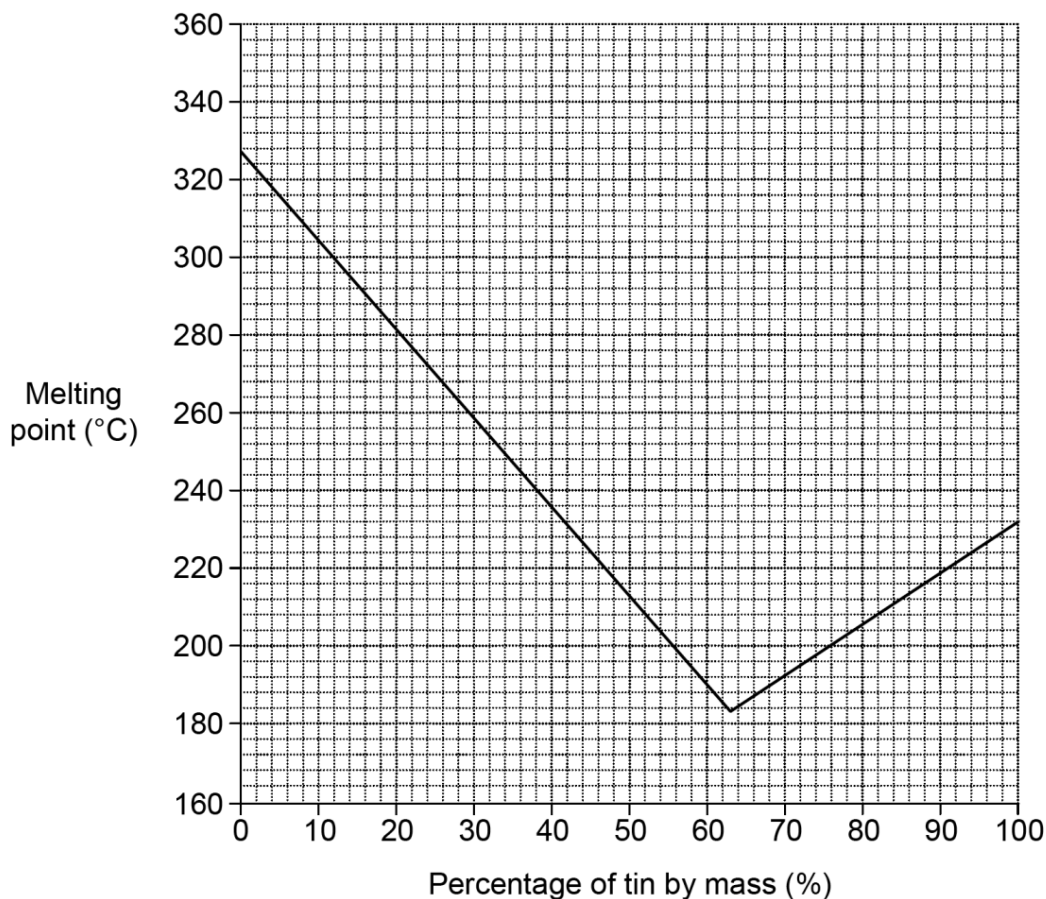

(i) Describe what happens to the melting point of solder as the percentage of tin in the mixture is increased.

You should refer to the graph in your answer.

.....

.....

.....

.....

.....

..... [2]

Candidates expressed their responses in a variety of ways but most correctly identified 63°C as a key feature of the data displayed in the graph, the point when the melting point changed from a decreasing trend to one of increase (as the percentage of tin by mass increased). Many candidates clearly demonstrated the skill of interpreting graphical representations of data. No clear pattern of errors was observed for this item. Candidates were familiar with ‘describing’ such events, rather than attempting to ‘explain’ them in the context of this question format.

Question 6 (b) (ii)

(ii) Use the graph to estimate:

- the melting point of a solder which contains 50% by mass of tin.

Melting point = °C

- another percentage of tin which gives a mixture with the **same** melting point as a mixture containing 50% by mass of tin.

Percentage of tin = %
[2]

Again, candidates demonstrated a confident interpretation of the graph. Many correctly estimated the melting point as 212°C and the percentage of tin as 85%.

Question 6 (b) (iii)

(iii) Use the graph to calculate the mass of tin that would need to be mixed with 7.2 g of lead to create a solder that melts at 280 °C.

Show your working and any readings that you have taken from the graph.

Mass of tin =g **[3]**

Many candidates struggled to calculate the mass of tin (g) as outlined in the stem of this item. Relatively few presented the correct value but a number were given 1 mark for correctly observing that 20% tin was involved. This credited the ability of candidates to read 20% tin against 280°C melting point.

Question 7 (a) (i)

- 7 (a) Two resistors, $R_1 = 22 \Omega$ and $R_2 = 47 \Omega$ are connected in parallel and attached to a dc power supply as shown below.

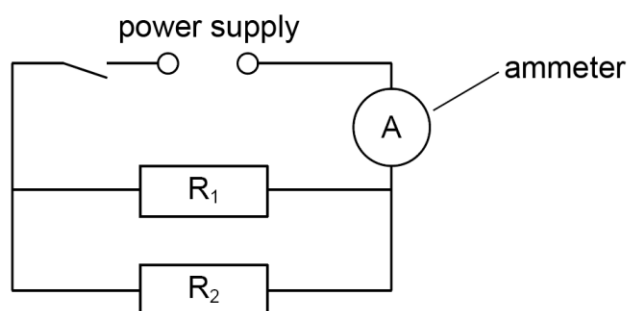

You may need the following equations to answer the questions.

Potential difference (V) = current (A) \times resistance (Ω)
 Charge transferred (C) = current (A) \times time (s)
 Energy transferred (J) = charge (C) \times potential difference (V)
 Resistors in parallel $\frac{1}{R_t} = \frac{1}{R_1} + \frac{1}{R_2} + \frac{1}{R_3}$

- (i) Calculate the combined resistance R_t of resistors R_1 and R_2 .
 Give your answer to 2 significant figures.

$R_t = \dots\dots\dots \Omega$ [2]

The majority of candidates did not complete the calculation correctly. However, they were able to demonstrate that $1/R_t = 0.067$. This was given with 1 mark.

Misconception

Some candidates incorrectly calculated $22 + 47 = 69$, without recognition of the fractions presented in the equation for resistors in parallel ($1/R_t = 1/R_1 + 1/R_2$).

Question 7 (a) (ii)

(ii) When the switch is closed there is a current of 0.30 A in the ammeter.

Calculate the potential difference across the power supply.

potential difference = V [1]

Although many candidates struggled to complete the calculation correctly, they were nonetheless given 1 mark as an error carried forward from their response to **Q7(a)(i)** x 0.3. Such students had correctly used the potential difference equation provided, inserting the value they had calculated for resistance.

Question 7 (a) (iii)

(iii) The switch is closed for 1 minute and then opened.

Calculate the charge transferred in R_2 and give the name of the unit of charge.

Charge transferred in R_2 =

Name of unit =

[3]

This calculation was challenging for most candidates. Some did recall that the units were Coulombs but few progressed further with the expected calculation steps. No clear pattern of alternative responses was identified; however, it was observed that some candidates incorrectly calculated 0.3×60 and others expressed the units as ohms.

Question 7 (a) (iv)

(iv) Calculate the energy transferred in R_2 in one minute.



Energy transferred in R_2 =J [1]

Although this calculation was also challenging, a number of candidates obtained the mark for correctly multiplying their responses to **Q7(a)(iii)** and **(a)(ii)**. Such students had applied the equation provided to the values they had determined earlier in the question.

Question 7 (b)

(b) Draw a circuit diagram which could be used to investigate how the resistance of a filament lamp changes with current.

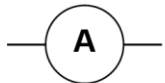
You will need to use the circuit symbols shown below.

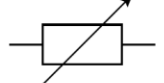
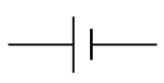
				
Ammeter	Voltmeter	Lamp	Variable Resistor	Cell

[2]

This was an unusual item format for this type of electronic question. However, many candidates did very well and obtained marks for both correctly including the lamp, cell, ammeter, and variable resistor in series and for drawing the voltmeter in parallel with the lamp.

Assessment for learning



Some candidates struggled to locate the position of the voltmeter correctly and often placed it adjacent to the ammeter. It is recommended that candidates practice this skill in more detail so that they become increasingly confident with the construction of circuit diagrams.

Copyright information

Question 5 – image of racing bike handlebar
Shutterstock 188361395 by Chatchawat Prasertsom

Supporting you

Teach Cambridge

Make sure you visit our secure website [Teach Cambridge](#) to find the full range of resources and support for the subjects you teach. This includes secure materials such as set assignments and exemplars, online and on-demand training.

Don't have access? If your school or college teaches any OCR qualifications, please contact your exams officer. You can [forward them this link](#) to help get you started.

Reviews of marking

If any of your students' results are not as expected, you may wish to consider one of our post-results services. For full information about the options available visit the [OCR website](#).

Keep up-to-date

We send a monthly bulletin to tell you about important updates. You can also sign up for your subject specific updates. If you haven't already, [sign up here](#).

OCR Professional Development

Attend one of our popular CPD courses to hear directly from a senior assessor or drop in to a Q&A session. Most of our courses are delivered live via an online platform, so you can attend from any location.

Please find details for all our courses for your subject on **Teach Cambridge**. You'll also find links to our online courses on NEA marking and support.

Signed up for ExamBuilder?

ExamBuilder is the question builder platform for a range of our GCSE, A Level, Cambridge Nationals and Cambridge Technicals qualifications. [Find out more](#).

ExamBuilder is **free for all OCR centres** with an Interchange account and gives you unlimited users per centre. We need an [Interchange](#) username to validate the identity of your centre's first user account for ExamBuilder.

If you do not have an Interchange account please contact your centre administrator (usually the Exams Officer) to request a username, or nominate an existing Interchange user in your department.

Need to get in touch?

If you ever have any questions about OCR qualifications or services (including administration, logistics and teaching) please feel free to get in touch with our customer support centre.

Call us on
01223 553998

Alternatively, you can email us on
support@ocr.org.uk

For more information visit

 **ocr.org.uk/qualifications/resource-finder**

 **ocr.org.uk**

 **facebook.com/ocrexams**

 **twitter.com/ocrexams**

 **instagram.com/ocrexaminations**

 **linkedin.com/company/ocr**

 **youtube.com/ocrexams**

We really value your feedback

Click to send us an autogenerated email about this resource. Add comments if you want to. Let us know how we can improve this resource or what else you need. Your email address will not be used or shared for any marketing purposes.



I like this



I dislike this

Please note – web links are correct at date of publication but other websites may change over time. If you have any problems with a link you may want to navigate to that organisation's website for a direct search.



OCR is part of Cambridge University Press & Assessment, a department of the University of Cambridge.

For staff training purposes and as part of our quality assurance programme your call may be recorded or monitored. © OCR 2023 Oxford Cambridge and RSA Examinations is a Company Limited by Guarantee. Registered in England. Registered office The Triangle Building, Shaftesbury Road, Cambridge, CB2 8EA. Registered company number 3484466. OCR is an exempt charity.

OCR operates academic and vocational qualifications regulated by Ofqual, Qualifications Wales and CCEA as listed in their qualifications registers including A Levels, GCSEs, Cambridge Technicals and Cambridge Nationals.

OCR provides resources to help you deliver our qualifications. These resources do not represent any particular teaching method we expect you to use. We update our resources regularly and aim to make sure content is accurate but please check the OCR website so that you have the most up to date version. OCR cannot be held responsible for any errors or omissions in these resources.

Though we make every effort to check our resources, there may be contradictions between published support and the specification, so it is important that you always use information in the latest specification. We indicate any specification changes within the document itself, change the version number and provide a summary of the changes. If you do notice a discrepancy between the specification and a resource, please [contact us](#).

You can copy and distribute this resource freely if you keep the OCR logo and this small print intact and you acknowledge OCR as the originator of the resource.

OCR acknowledges the use of the following content: N/A

Whether you already offer OCR qualifications, are new to OCR or are thinking about switching, you can request more information using our [Expression of Interest form](#).

Please [get in touch](#) if you want to discuss the accessibility of resources we offer to support you in delivering our qualifications.